

Rosemount™ Wedge Primary Element

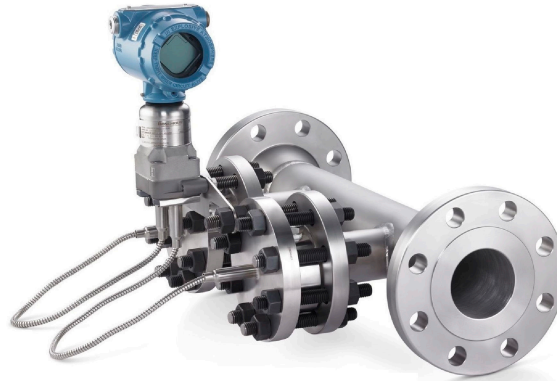

- Fully assembled flow meter design for accurate measurement of difficult or erosive fluids
- Offered with Emerson's Rosemount Remote Seal Assemblies for standard, abrasive, high temperature, cold environment, and remote mount applications
- Wedge-shaped element without any critical sharp edges enhances wear resistance

DP Flow Meter selection guide

Rosemount integrated DP Flow Meters arrive fully assembled, configured, and leak tested for out-of-the-box installation.



Rosemount 9195 Wedge Primary Elements save time and expense when measuring flow in difficult, harsh, or high temperature applications.

- Wedge design withstands abrasive applications
- Discharge coefficient uncertainty (accuracy) up to $\pm 1.0\%$ calibrated, $\pm 3.0\%$ uncalibrated
- Remote Seal packages allow pre-configured solutions designed for certain applications
- Reduce installation costs compared to traditional wedge pipe spools
- Wedge primary element design is based on ISO 5167-6
- Available in various connection styles providing installation flexibility

When paired with a Rosemount Pressure transmitter, the Rosemount 9195 Wedge Flow Meter enables best-in-class flow measurement utilizing advanced functionality.

- Up to $\pm 1.0\%$ uncertainty of discharge coefficient
- Multivariable capabilities allow for real time fully compensated mass and energy flow
- Advanced diagnostics predict and prevent abnormal process conditions
- Installation-ready wireless flow solution
- Ultra for Flow measures percent-of-reading performance over 14:1 flow turndown
- 15-year stability, 15-year warranty with 3051S
- Available with 4–20 mA Modbus[®], 4–20 mA HART[®], WirelessHART[®], and FOUNDATION[™] Fieldbus Protocols

Contents

DP Flow Meter selection guide.....	2
Rosemount [™] 9195 Wedge Primary Element.....	3
Rosemount [™] DP Level remote diaphragm seal ordering information.....	10
Specifications.....	13
Dimensional Drawings.....	15

Rosemount™ 9195 Wedge Primary Element

The Rosemount 9195 Wedge Flow Meter offers a fully assembled design for accurate measurement of fluids that wear or plug other meters. The wedge element is abrasion-resistant due to the shallow approach angle of the fluid and the lack of critical sharp edges. Highly viscous fluids can be measured accurately due to the linear response of the meter even at very low Reynolds Number. Designed to specifically accompany the Rosemount 9195 Wedge Primary Element, the optional Application Packages simplify ordering to ensure the correct remote seal system is specified based on application needs.

- Typical 9195 model code: 9195 S 040 S40 S S 40 A3 E

VIEW PRODUCT >	CONFIGURE >
-----------------------------------	--------------------------------

Many products are configurable online using our Product Configurator. Select the **Configure** button or visit our [website](#) to start. With this tool's built-in logic and continuous validation, you can configure your products more quickly and accurately.

Specifications and options

The purchaser of the equipment must specify and select the product materials, options, or components.

Optimizing lead time

The starred offerings (★) represent the most common options and should be selected for the fastest delivery times. The non-starred offerings are subject to additional delivery lead time.

Wedge Primary Element overview

Figure 1: Wedge Components

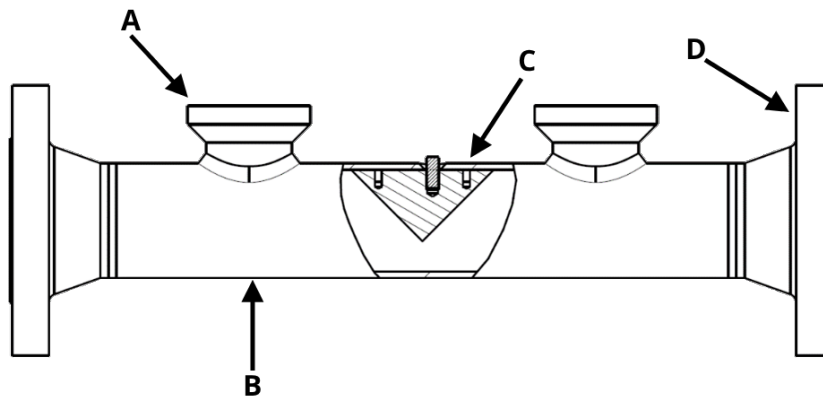



- A. Transmitter Connection
- B. Pipe Spool
- C. Wedge Element
- D. Process Connection

Required model components

Model

Code	Description	
9195	Wedge Meter Primary Element	★

Transmitter connection style

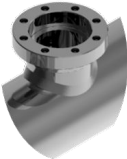
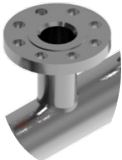
Code	Description	Image	
T	Direct mount ½" NPT connection		
R	Remote mount ½" NPT connection		★
S	Compact remote seal connection		
F	2" NPS/DN50 flanged ANSI/DIN connection		

Line size

Code	Description	
020	2-in. (50 mm)	★
030	3-in. (80 mm)	★
040	4-in. (100 mm)	★
060	6-in. (150 mm)	★
080	8-in. (200 mm)	★

Pipe schedule

Code	Description	
S40	Schedule 40	★
S80	Schedule 80	★

Pipe spool material

Code	Description	
S	316 stainless steel	★

Wedge element material

Code	Description	
S	316 stainless steel	★

Wedge element h/d

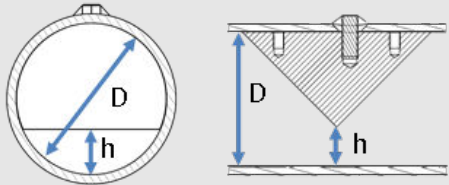
Code	Description		
20	0.20 h/D		★
25	0.25 h/D		
30	0.30 h/D		★
35	0.35 h/D		
40	0.40 h/D		★
45	0.45 h/D		
50	0.50 h/D		★
55	0.55 h/D		
60	0.60 h/D		
99	Special h/D ratio		

Process connection

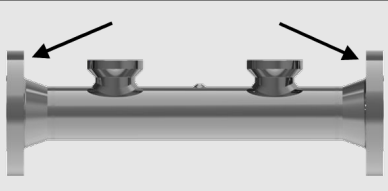
Code	Description		
A1	Class 150 RF ASME B16.5, slip-on		★
A3	Class 300 RF ASME B16.5, slip-on		★
A6	Class 600 RF ASME B16.5, slip-on		★
D1	PN16 EN-1092-1 RF, slip-on		★
D2	PN40 EN-1092-1 RF, slip-on		★
D3	PN40 EN-1092-1 RF, slip-on		★
W1	Class 150 RF ASME B16.5, weld-neck		
W3	Class 300 RF ASME B16.5, weld-neck		
W6	Class 600 RF ASME B16.5, weld-neck		
N1	PN16 EN-1092-1 RF, weld-neck		
N2	PN40 EN-1092-1 RF, weld-neck		
N3	PN100 EN-1092-1 RF, weld-neck		

Remote seal connection gasket material





Code	Description		
0	No gasket supplied		★
E	KLINGERSIL® C-4401		
J	PTFE		
N	GraFoil™ GHB		
K	Barium Sulfate Filled PTFE		
6	KLINGERSIL® top-chem 2000		



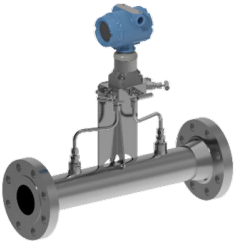

Additional options

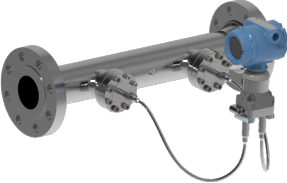
Extended product warranty

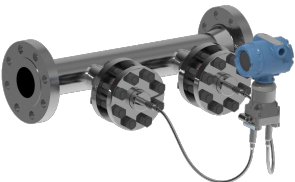
Code	Description	
WR3	3-year limited warranty	★
WR5	5-year limited warranty	★

Transmitter connection assembly instructions

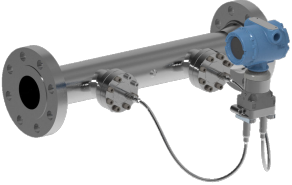
Code	Description	Image	
S3	Attach/configure transmitter and 0305 manifold		★
S4 ⁽¹⁾	Attach remote seal assembly, direct mount transmitter		★
S5 ⁽¹⁾	Attach remote seal assembly, remote mount transmitter		★
S6 ⁽¹⁾	Attach remote seal assembly, flushing rings, direct mount transmitter		★
S7 ⁽¹⁾	Attach remote seal assembly, flushing rings, remote mount transmitter		★

Code	Description	Image	
S8 ⁽¹⁾	Attach remote seal assembly with extension, direct mount transmitter		 ★
S9 ⁽¹⁾	Attach remote seal assembly with extension, remote mount transmitter		 ★

(1) If the branch type is F, options S4, S6, and S8 are unavailable with DIN style connections (Option codes D1, D2, D3, N1, N2, N3). Options S5, S7, and S9 are available, but will be shipped unassembled. If the branch type is S, T, or R, the items will be shipped assembled.

Alternate meter orientation

Code	Description	
R0	Manifold in a right-handed orientation	★

Pressure testing

Code	Description	
P1	Hydrostatic testing with certificate	

Material testing

Code	Description	
V1	Dye penetrant exam	

Material examination

Code	Description	
V2	Radiographic examination with certificate	

Positive material identification (PMI)

Code	Description	
Q76	PMI verification and certificate	

Flow calibration

Code	Description	
WD	Flow calibration	

Special inspection

Code	Description	
QC1	Visual and dimensional inspection with certificate	★

Material traceability certification

Code	Description	
Q8	Material traceability certification per EN 10204:2004 3.1	★

Code conformance

Code	Description	
J3	ANSI/ASME B31.3	

Country Certification

Code	Description	
J1	Canadian Registration (CRN)	
J6	European Pressure Directive (PED)	

NACE certificate

Materials of construction comply with metallurgical requirements within NACE MR0175/ISO-15156 for sour oil field production environments. Environmental limits apply to certain materials. Consult latest standard for details. Selected materials also conform to NACE MR0103 for sour refining environments.

Code	Description	
Q15	Certificate of compliance to NACE MRO175/ISO 15156 for wetted materials	

Rosemount™ DP Level remote diaphragm seal ordering information

The wedge meter can be paired with DP Level remote diaphragm seal assemblies to:

- Mitigate plugging
- Flush the DP taps
- Measure high temperature fluids

The wedge meter can be ordered in the following remote seal styles:

- WSP Saddle Seal
- FFW Flush Flanged Seal
- EFW Extended Flanged Seal

Pressure transmitters available for assembly:

- Rosemount 3051S Coplanar™ Pressure Transmitter
- Rosemount 3051S MultiVariable™ Transmitter
- Rosemount 4088 MultiVariable™ Transmitter
- Rosemount 3051SAL

The remote seal model options contained in the ordering tables below have been engineered specifically for wedge flow meter applications.

For a list of complete options and additional information please reference the Rosemount DP Level Transmitters and 1199 Diaphragm Seal Systems [Product Data Sheet](#).

Figure 2: Remote Seal Ordering Table: Compact WSP Style

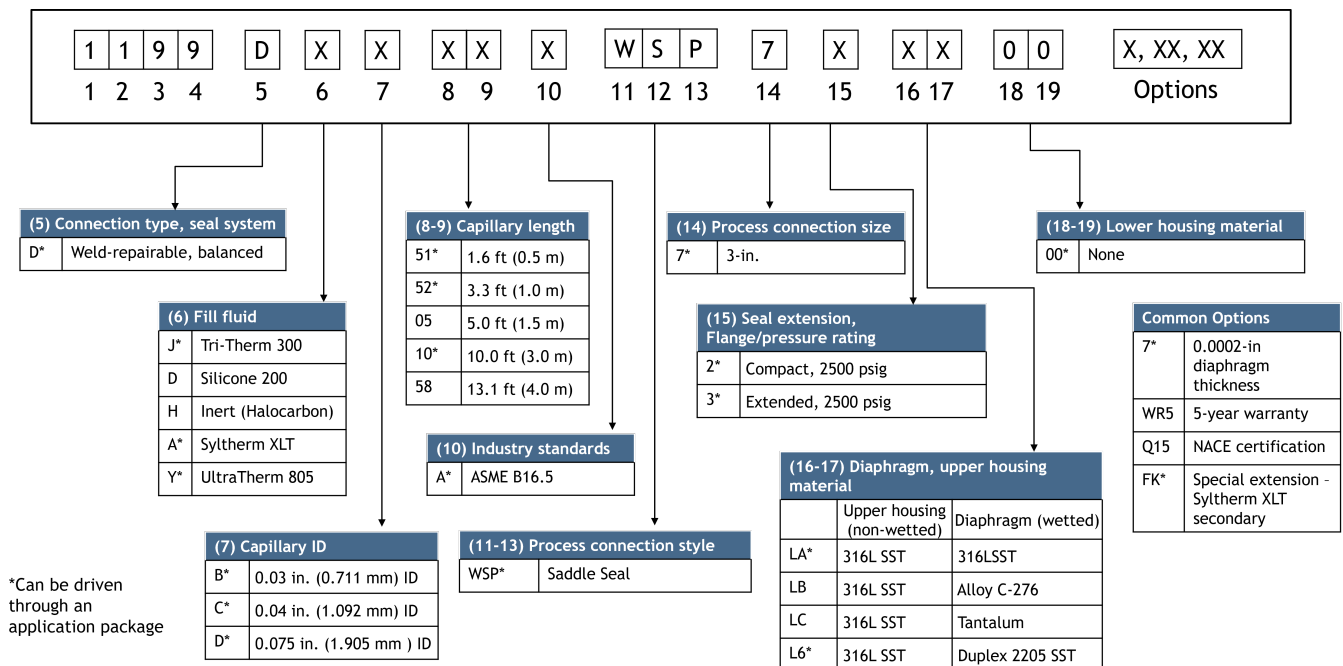
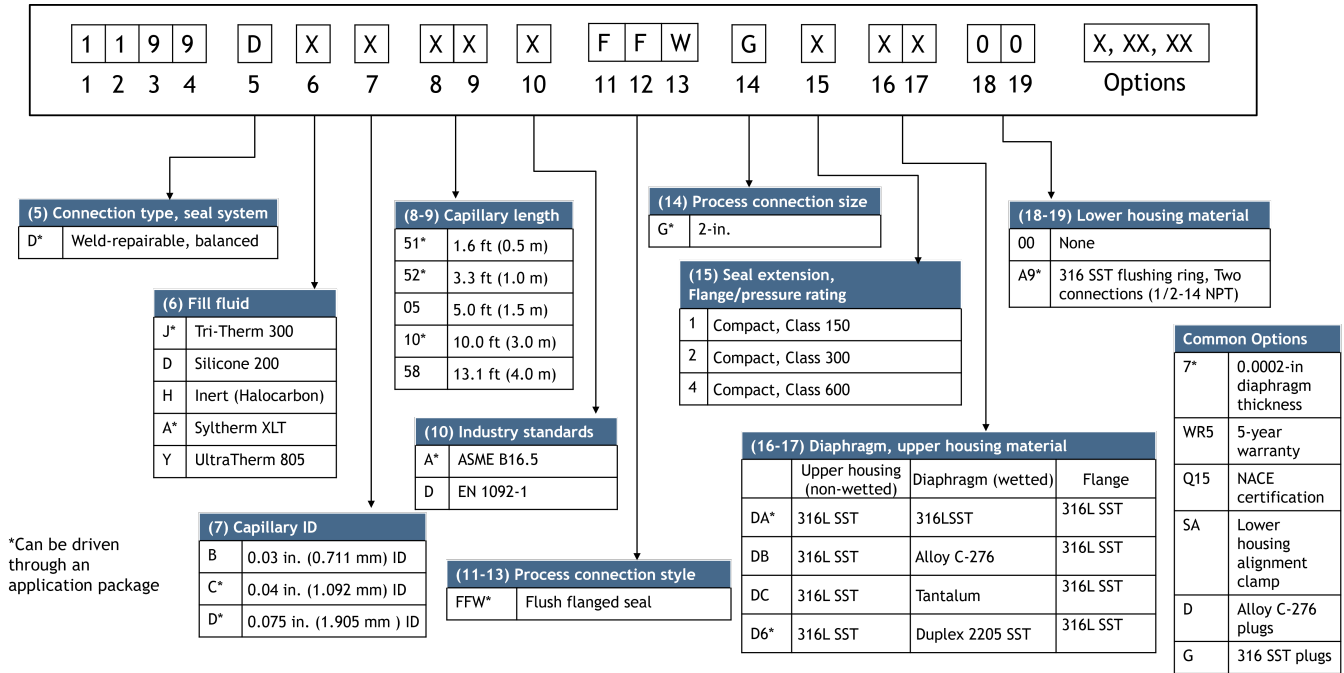

Figure 3: Remote Seal Ordering Table: Flanged Style



Remote seal application packages simplify ordering and improve performance by using pre-defined remote seal model options specifically engineered for flow applications and designed for optimal response times. The following application packages have been incorporated into the DP Flow Sizing & Selection tool to drive the corresponding remote seal options. Combinations of the packages cited below are available.

Table 1: Wedge Meter Remote Seal Application Package Information

Application package name	Description	Key feature	Example model number
Standard	Flexible for general applications, for use in process temperatures up to 572°F (300°C)	<ul style="list-style-type: none"> Tri-Therm 300 fill fluid 1.6 ft (0.5m) capillary length <p>Note 6-8 NPS meters use a 1.0m capillary.</p>	1199DJD51AWSP72LA007 1199DJD51AFFWG2DA007
Abrasive	Diaphragm material that's stronger and resistant to wear	<ul style="list-style-type: none"> 2205 Duplex diaphragm material 3 mil diaphragm thickness 	1199DJD51AWSP72L6000 1199DJD51AFFWG2D6A90
Ultra-high process temperature	Can withstand process temperatures of 770°F (410°C)	<ul style="list-style-type: none"> Thermal Range Expander Technology UltraTherm 805 & Tri-Therm 300 fill fluids 	1199DYC51AWSP72LA007FK 3051SAL1CD2AA1A57CMYFFG2DA00W7
Cold environment	Suitable in applications with constant ambient or process temperatures between -40 °F (-40 °C) to 0 °F (-18 °C), faster response time	<ul style="list-style-type: none"> Syltherm XLT fill fluid 0.040" (1,092 mm) capillary ID 	1199DAC51AWSP72LA007 1199DAC51AFFWG2DA007
Remote mount DP transmitter	Flexible mounting configuration, that maintains an acceptable time response	<ul style="list-style-type: none"> Tri-Therm 300 fill fluid ~10ft (3 m) of capillary length 	1199DAC58AWSP72LA007 1199DAC58AFFWG2DA007

Response time of remote seal system

Temperature	Application package	Response time in seconds (s)
< 32 °F (< 0 °C) ambient	Abrasive	0.600
	Cold environment	0.525
	Remote mount	3.700
75.2 °F (24 °C) ambient	Abrasive	0.550
	Cold environment	0.510
	Remote mount	2.200
	Standard	0.520
< 32 °F (< 0 °C) ambient	Ultra high process temperature	0.573
75.2 °F (24 °C) ambient	Ultra high process temperature	0.573

Specifications

Performance specifications

Table 2: Wedge Meter Primary Element Uncertainty – 95% Confidence

Wedge ratio (h/D)	Discharge coefficient uncertainty	
	Calibration option (WD)	Standard (no calibration specified)
0.20 - 0.60	± 1.00%	± 3.00%

Total system performance

The above uncertainty is applicable to the primary element and does not include any impacts from remote seals or differential pressure transmitters. Using the Remote Seal Packages with Rosemount 1199 remote seals and a 3051S DP transmitter, system time response is generally under 0.6 seconds and the transmitter performance band is less than 0.25% of DP span. System response time and performance band are application-dependent – contact an Emerson representative or see the product manual for more information.

Example: Standard remote seal package, 212°F process temperature at 1500psi, 68°F ambient temperature results in a 0.6 second system time response and a 0.23% of DP Span transmitter performance band.

Sizing

Contact an Emerson sales associate for assistance in sizing or visit our website at Emerson.com to access our DP Flow Sizing and Selection Tool.

To complete the Configuration Data Sheet go to: [Emerson.com/Rosemount/DP-Flow-Configuration-Assistant](https://www.emerson.com/Rosemount/DP-Flow-Configuration-Assistant).

Functional specifications

Service

- Liquid
- Gas
- Steam

Process temperature limits

Direct mount transmitter (transmitter connection style option code T):

- -40 to 450 °F (-40 to 232 °C)

Remote mount transmitter (transmitter connection style option code R):

- -40 to 1000 °F (-40 to 537 °C)

Remote seal system (transmitter connections style option codes S and F):

- Dependent on fill fluid selection, and gasket material. Refer to the DP Level Transmitters and Diaphragm Seal Systems data sheet

Maximum allowable differential pressure limits

- 1000 in H₂O (2.49 bar)

Maximum working pressure

Pressure retention per ANSI B16.5 Class 600 or ordered flange rating.

Vibration effect

Qualified per IEC60068-2-6 (10-500 Hz, 19.6 m/s² acceleration amplitude (2g), 20 sweep cycles) for field with general application or pipeline with low vibration level.

For applications where vibration is expected, remote mount configuration is recommended.

Physical specifications

Physical details

Body, flanges, and DP branches

- 316/316LSST

Wedge element

- 316/316LSST

Flanges studs, nuts, and gaskets ⁽¹⁾

- Flanged branch connection
 - Studs — A193 Grade B7 Carbon Steel
 - Nuts — A194 Grade 2H Carbon Steel
- Compact branch connection
 - Screws — A193 GR 304 Stainless Steel
 - Studs — A193 GR B8 304 Stainless Steel
 - Nuts — A194 GR 304 Stainless Steel
- Gaskets – KLINGERSIL[®] C-4401, PTFE, GraFoil[®] GHB, Barium Sulfate Filled PTFE, KLINGER[®] top-chem 2000, Ethylene Propylene
- Gaskets
 - Flange gaskets for remote seal connections are supplied when ordered as part of an assembly. Gaskets should be replaced when the Rosemount 9195 is disassembled.

Transmitter connections

Direct mount:

- Available with Rosemount 3051SMV, 3051S, 4088 Pressure Transmitters.

Remote mount:

- Remote mount transmitter connections available with ½-in. NPT

Wedge element design

Wedge element design standard:

- Built per ISO 5167-6 (2022)

Wedge h/D ratio:

- Standard ratios: 0.20, 0.30, 0.40, 0.50

(1) Provided when either compact or flanged 1199 remote seals are ordered as part of the assembly.

Dimensional Drawings

Figure 4: Rosemount 9195 Wedge Primary Element: Compact Style

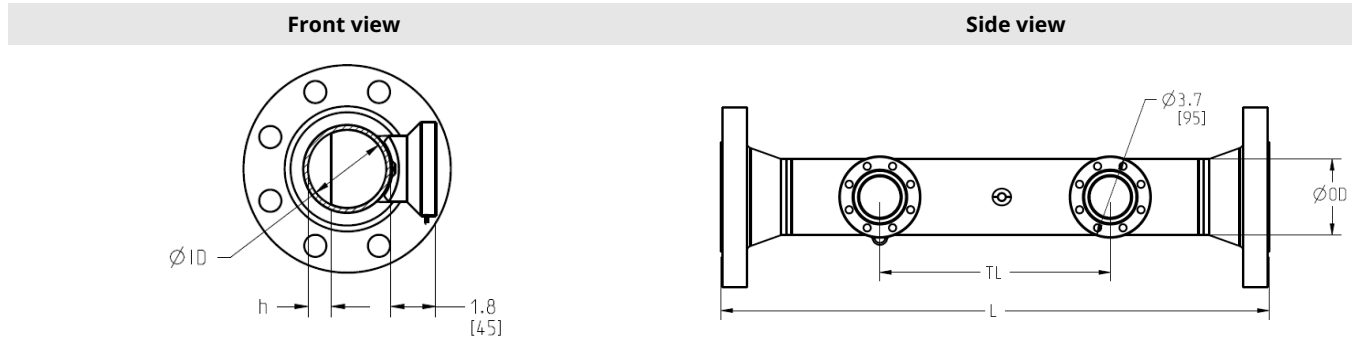

Figure 5: Rosemount 9195 Wedge Flow Meter: Compact Style

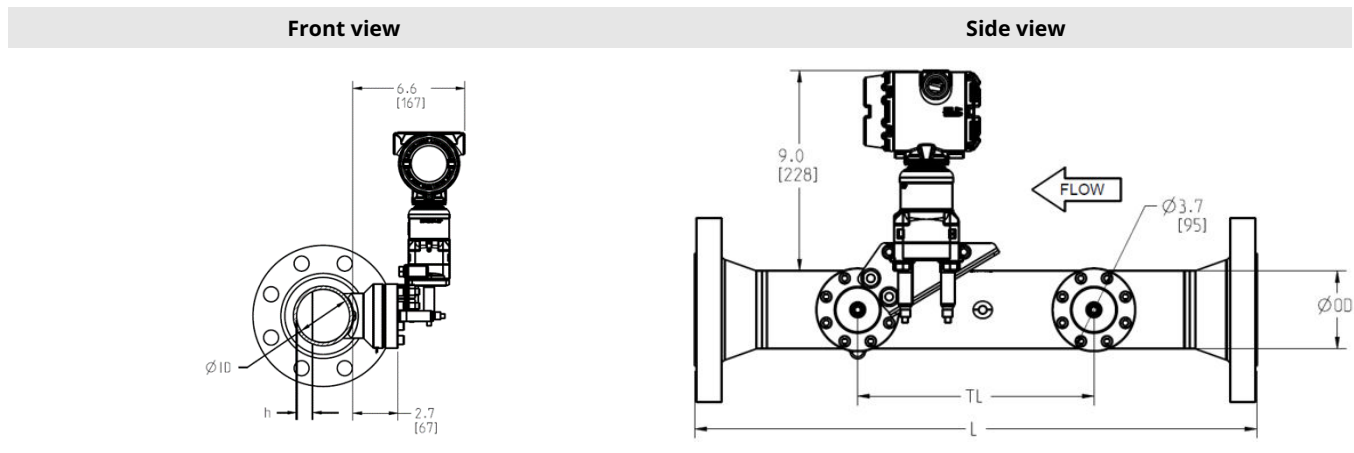

Figure 6: Rosemount 9195 Wedge Primary Element 1/2" NPT Style

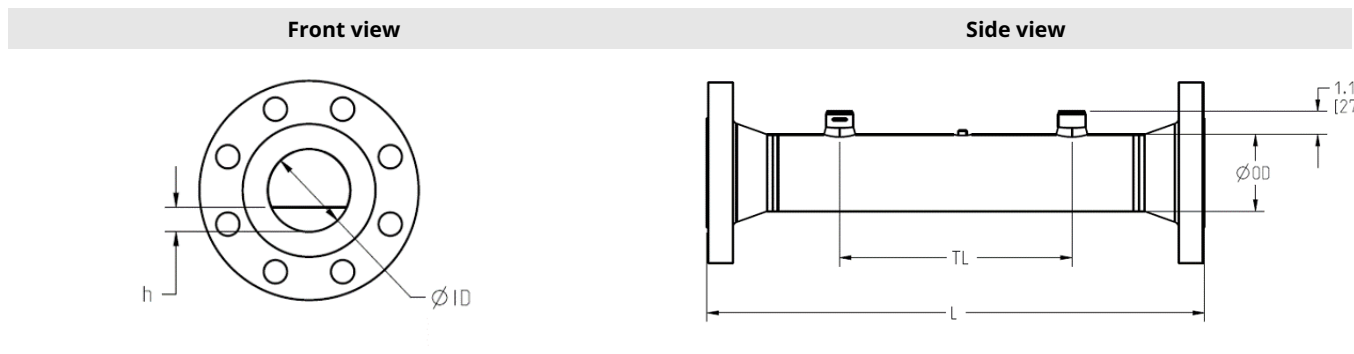

Figure 7: Rosemount 9195 Wedge Flow Meter: 1/2" NPT Style

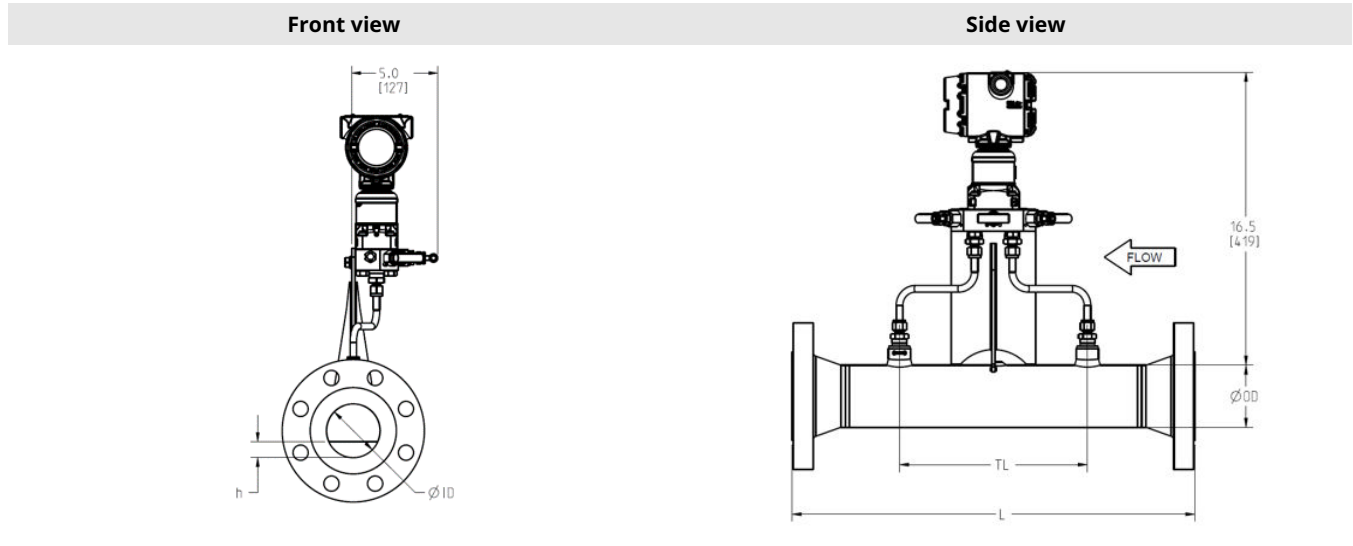

Figure 8: Rosemount 9195 Wedge Primary Element: 2" Flanged Style

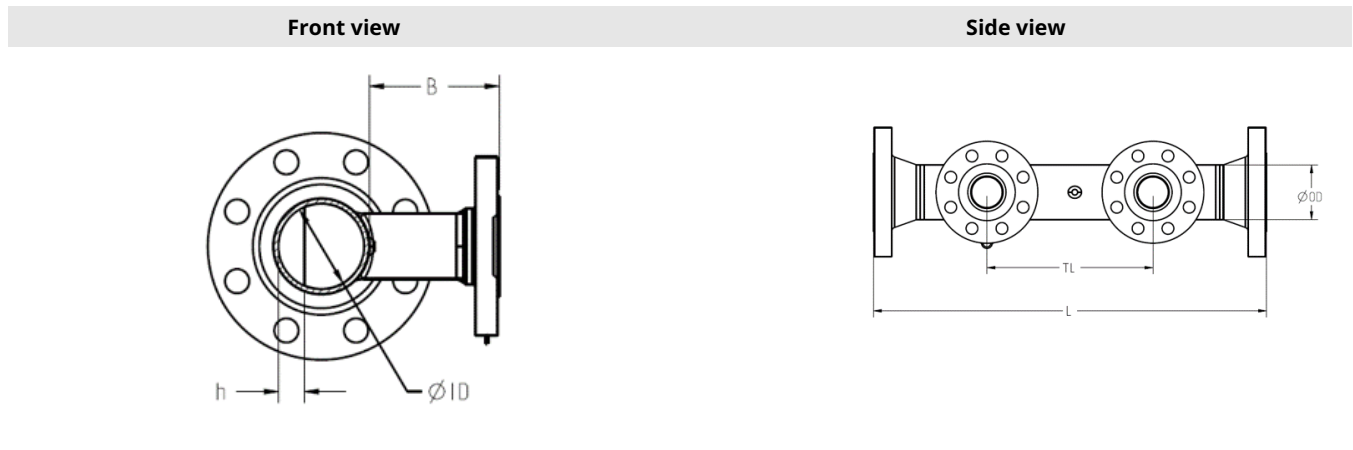
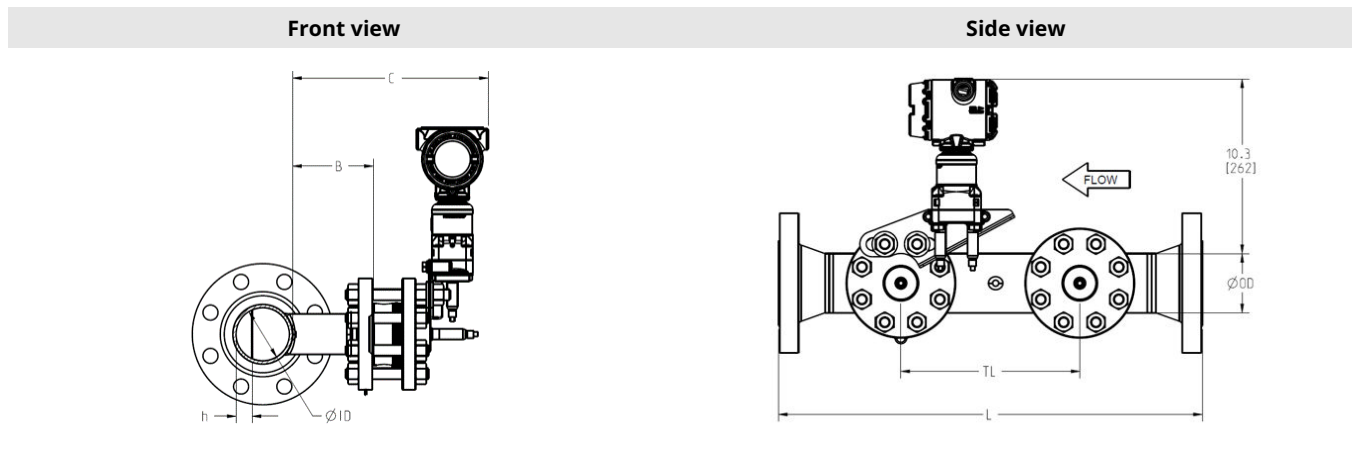

Figure 9: Rosemount 9195 Wedge Flow Meter: 2" Flanged Style



h	Wedge Ratio (h/D)								
	0.20	0.25	0.30	0.35	0.40	0.45	0.50	0.55	0.60
Line size	0.20	0.25	0.30	0.35	0.40	0.45	0.50	0.55	0.60
2" NPS Sch40	0.42	0.53	0.63	0.74	0.84	0.95	1.05	1.16	1.26
3" NPS Sch40	0.62	0.78	0.93	1.09	1.25	1.40	1.56	1.71	1.87
4" NPS Sch40	0.82	1.02	1.22	1.43	1.63	1.83	2.04	2.24	2.45
6" NPS Sch40	1.23	1.53	1.84	2.14	2.45	2.76	3.06	3.37	3.68
8" NPS Sch40	1.61	2.01	2.42	2.82	3.22	3.62	4.03	4.43	4.83
2" NPS Sch80	0.40	0.50	0.60	0.69	0.79	0.89	0.99	1.09	1.19
3" NPS Sch80	0.59	0.74	0.89	1.04	1.18	1.33	1.48	1.63	1.78
4" NPS Sch80	0.78	0.97	1.17	1.36	1.56	1.75	1.95	2.14	2.33
6" NPS Sch80	1.17	1.46	1.75	2.05	2.34	2.63	2.92	3.22	3.51
8" NPS Sch80	1.54	1.93	2.32	2.70	3.09	3.47	3.86	4.25	4.63

Line Size	OD (in.)	ID (in.)
2" NPS Sch40	2.375	2.102
3" NPS Sch40	3.5	3.114
4" NPS Sch40	4.5	4.075
6" NPS Sch40	6.625	6.127
8" NPS Sch40	8.625	8.049
2" NPS Sch80	2.375	1.983
3" NPS Sch80	3.5	2.958
4" NPS Sch80	4.5	3.890
6" NPS Sch80	6.625	5.846
8" NPS Sch80	8.625	7.720

L	½" NPT			Compact Seals/Flanged Seals			½" NPT			Compact Seals/Flanged Seals		
	150#	300#	600#	150#	300#	600#	PN16	PN40	PN100	PN16	PN40	PN100
Line Size	150#	300#	600#	150#	300#	600#	PN16	PN40	PN100	PN16	PN40	PN100
2" NPS (½" NPT and Compact Seals)	17.83	18.33	19.09	20.32	20.82	21.58	16.38	16.61	18.19	18.87	19.10	20.68
2" NPS Sch40 (Flanged Seals)				17.58	18.08	18.84				16.13	16.36	17.94
2" NPS Sch80 (Flanged Seals)				17.15	17.65	18.41				15.70	38.54	38.54
3" NPS	21.98	22.72	23.48	24.47	25.21	25.97	20.41	21.04	22.62	22.90	23.53	25.11
4" NPS	25.94	26.70	28.44	28.43	29.19	30.93	24.03	25.05	27.02	26.52	27.54	29.51
6" NPS	34.32	36.21	38.19	36.81	37.57	39.55	31.65	33.23	36.38	34.14	35.72	38.87
8" NPS	42.44	44.13	46.37	44.73	45.49	47.73	39.13	41.17	44.48	41.62	43.66	46.97

TL	Wedge Ratio (h/D)								
	0.20	0.25	0.30	0.35	0.40	0.45	0.50	0.55	0.60
Line Size	0.20	0.25	0.30	0.35	0.40	0.45	0.50	0.55	0.60
2" NPS Sch40	7.583	7.373	7.163	6.953	6.742	6.532	6.322	6.112	5.902
3" NPS Sch40	11.226	10.915	10.604	10.292	9.981	9.669	9.358	9.047	8.735
4" NPS Sch40	14.687	14.279	13.872	13.464	13.057	12.649	12.242	11.834	11.427
6" NPS Sch40	22.074	21.462	20.849	20.236	19.623	19.011	18.398	17.785	17.173
8" NPS Sch40	28.995	28.190	27.385	26.580	25.775	24.970	24.165	23.360	22.555
2" NPS Sch80	7.155	6.956	6.758	6.560	6.362	6.163	5.965	5.767	5.568
3" NPS Sch80	10.667	10.371	10.075	9.780	9.484	9.188	8.892	8.596	8.300
4" NPS Sch80	14.021	13.632	13.243	12.854	12.465	12.076	11.687	11.298	10.909
6" NPS Sch80	21.062	20.478	19.893	19.308	18.724	18.139	17.555	16.970	16.385
8" NPS Sch80	27.809	27.037	26.265	25.493	24.721	23.949	23.177	22.405	21.633

Figure 10: Direct Mount, Left-Handed vs. Right-Handed

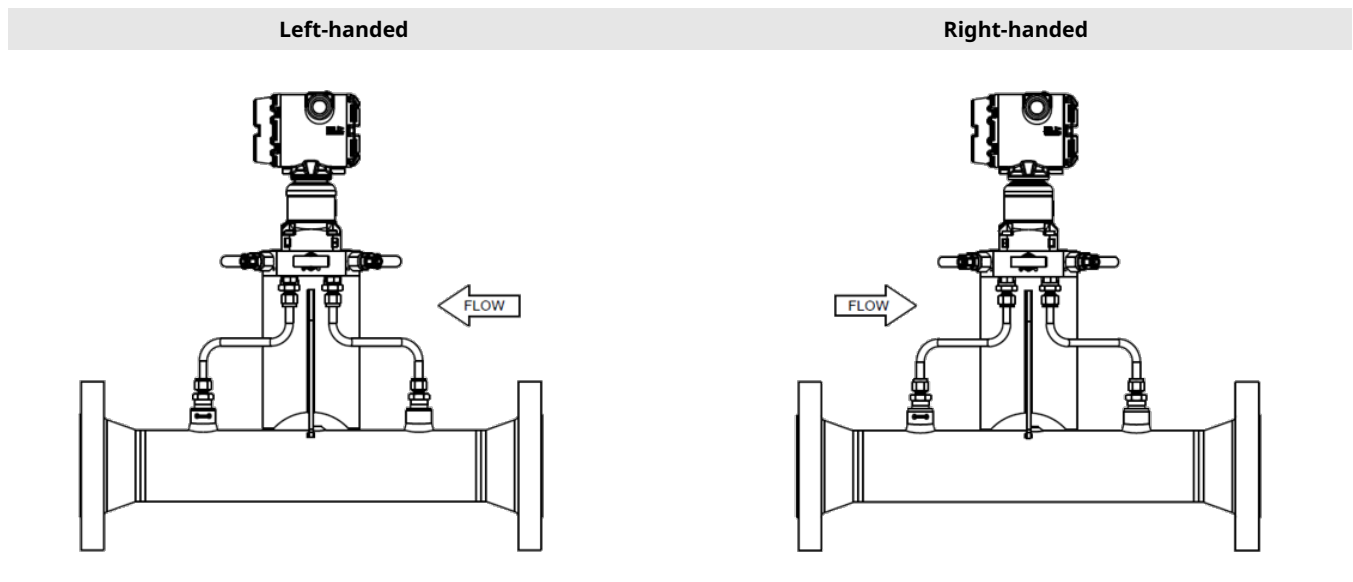

For more information: www.emerson.com

©2023 Emerson. All rights reserved.

Emerson Terms and Conditions of Sale are available upon request. The Emerson logo is a trademark and service mark of Emerson Electric Co. Rosemount is a mark of one of the Emerson family of companies. All other marks are the property of their respective owners.

ROSEMOUNT™

