

# Micro Motion™ 1600 Transmitters



## **Repeatable, reliable, accurate measurements**

- Fast processing speed delivers the best response even in the most challenging applications such as filling and dosing, and batching
- Smart Meter Verification™ provides you with the confidence you need in your meter performance
- Zero verification confirms the calibration and indicates when it's time to re-zero the meter

## **A window into your process**

- Easy access to detailed measurement history gives you valuable insight into your process for better troubleshooting and optimization
- Real-time indication of multi-phase flow events allow for greater process control
- High-accuracy density measurement reduces or eliminates waste in your process while the embedded historian records upsets and process deviations

## **Productivity through simplified solutions**

- Designed to minimize the time and expertise needed to install and operate the flow meter
- Ethernet version includes multiple protocols on the main channel, plus a configurable I/O channel (milliamp output, frequency output or discrete output)
- Offline configuration and auditing through the service port

## Micro Motion 1600 transmitters

The 1600 transmitter delivers excellent measurement technology and offers unparalleled support – ensuring total measurement confidence, valuable process insight, and greater operational efficiency. This transmitter provides the scalability, compatibility, and performance that your application demands in a compact format.

### Simplified installation and commissioning

The 1600 provides an intuitive interface with a single wiring compartment.



### Smart Meter Verification: Advanced diagnostics for your entire system

Our online tool verifies that your meter performs as well as the day it was installed, giving you assurance in less than 90 seconds.



## Measurement history for easier troubleshooting and optimization

Detailed history files deliver key time-stamped information about your process from configuration changes and alerts to process events and statistics.

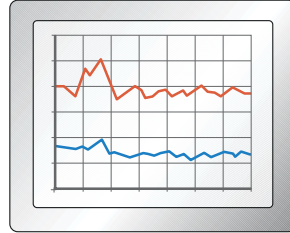

## Unmatched system connectivity and services interfaces

Ethernet output with EtherNet/IP® or Modbus® TCP — plus one configurable output.

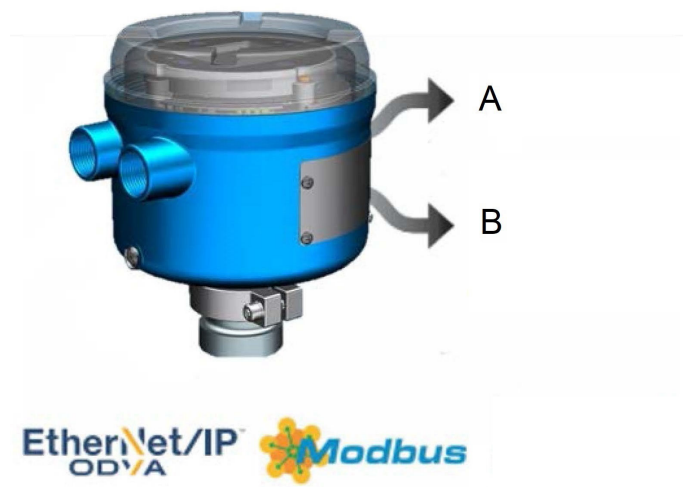

A. Ethernet port

B. 1 configurable I/O channel for mA, frequency, or discrete output

## Access information when you need it with asset tags

Newly shipped devices include a unique QR code asset tag that enables you to access serialized information directly from the device. With this capability, you can:

- Access device drawings, diagrams, technical documentation, and troubleshooting information in your MyEmerson account
- Improve mean time to repair and maintain efficiency
- Ensure confidence that you have located the correct device
- Eliminate the time-consuming process of locating and transcribing nameplates to view asset information

# 1600 enhancements

## Internal memory

The 1600 transmitter stores:

- Meter verification baseline and history
- Data log
- Licensing key

## Software licensing

Software licensing makes it possible to:

- Purchase permanent features and add them later
- Trial features, such as concentration measurement, for 60 days before buying
- Activate the Historian feature

## Large graphical display

- Supports multiple languages
- Supports full configuration capabilities directly from the display
- Provides understandable alert codes

## Two-phase flow detection

Two-phase flow detection provides clear, concise information about fluid conditions, including notification about the following fluid regimes:

- Single phase
- Moderate two-phase flow
- Severe two-phase flow

## Physical design

- Compact physical design with a single compartment
- Remote mounting bracket
- A Universal Service Port (USP) connects and transfers data using standard, USB-C terminal

## Troubleshooting tools

When licensed, the 1600 transmitter stores data in non volatile memory with Real Time Clock, including:

- Audit trail
- Alert log
- Long term data historian: 5-minute Min, Max, Avg, Std Dev (30 days)
- Short term data historian: 1-second data (7 days)

---

## Note

The 1600 transmitter contains descriptive alerts describing the issue and recommended steps for resolution.

- Follows NE 107 Standard

## Applications

Applications are custom designed programs and software that offer additional functionality and performance to transmitters. These applications are available through options in the transmitter model code. For details, see the Ordering information section.

### Smart Meter Verification

Provides a quick, complete assessment of a Micro Motion Coriolis meter, determining whether the meter has been affected by erosion, corrosion, or other influences affecting meter calibration. No secondary references are required to perform this operation, and the meter can continue normal process measurement while the test is in progress.

Smart Meter Verification Professional on the 1600 transmitter also offers non-uniform coating detection, detection of optimal flow range, and two-phase flow detection. A 90-day trial version is included with all transmitters. After the 90-day trial, a basic version of Smart Meter Verification will provide simple pass/fail results, and simple diagnostics that run without interrupting your processes.

### Discrete batch control

- Simple batch control based on totalizer values
- Channel B can be configured as Discrete Output
- Automatic Overshoot Compensation (AOC)
- Single stage batching available when ordered with Channel B and the Batching Software (BS) package option
- Batch ticket printing available with Ethernet (supports Epson TM88VI)

---

#### Note

Batching Software is recommended for fill durations greater than 10 seconds.

---

### Petroleum measurement and API correction option

- Accepts inputs from temperature and pressure devices
- Calculates values as per May, 2004 API Chapter 11.1
  - Relative density (specific gravity and API gravity) at reference temperature from observed density and temperature
  - Volume corrected to reference temperature and pressure
- Calculates flow-weighted average temperature and flow-weighted average observed density (specific gravity and API gravity)

### Filling and dosing

The 1600 is optimized for sub-second fills and very small containers. Operate and maintain your filling application at the highest degree of accuracy with the following:

- User-selectable fillings with integrated valve control
  - One-stage filling
  - Timed filling
- Automatic overshoot compensation
  - User-selectable Automatic Overshoot Compensation (AOC) modes: compensation off, AOC algorithm, fixed compensation value
  - Individual settings for each value
  - “Self-training” option
- User-selectable filling options
  - Measure in either Mass or Volume units
  - Count up or count down to target

- Track by either quantity or percent of target
- Digital communications
  - Continuous monitoring of density and temperature, for real-time quality control
  - “On-the-fly” changes to either the fill target or the recipe
- Clean In Place (CIP)
  - Rapid product changeover
  - Simplified maintenance
- Diagnostics customized for filling support
  - On-board logging of fill statistics (actual fill amount, actual fill time)
  - Fill statistics automatically reported to programmable logic controller (PLC)

---

**Note**

Filling and Dosing available when ordered with Channel B and the Fast Fill (FF) Software option. Fast Fill Software is recommended for fill durations less than 10 seconds.

---

**Concentration measurement**

Provides concentration measurement based on either industry-specific or liquid-specific units and relationships. Standard measurement options include:

- Industry-specific:
  - °Brix
  - °Plato
  - °Balling
  - °Baumé at SG60/60
  - Specific gravity
- Liquid-specific:
  - % HFCS
  - Concentration derived from reference density
  - Concentration derived from specific gravity

---

**Note**

Additionally, the application can be customized for site-specific concentration measurement (such as % HNO<sub>3</sub>, % NaOH).

---

**Advanced Phase Measurement**

- Accurately measures liquid or gas flow in limited multiple-phase conditions
  - Immediate and continuous access to production or process data
  - Real time reporting of Gas Void Fraction (GVF)
- Facilitates reliable measurement at a fraction of the cost of true multi-phase meters
  - Historian automatically captures all production data
  - Little to no maintenance or calibration
- Combines with concentration measurement to measure two liquids in the presence of gas
  - Improves concentration measurement in processes with intermittent entrained gas

# Electrical connections

## Electrical isolation

Each I/O channel is isolated +/-50VDC from all other outputs and earth ground.

## Ethernet version

Connection	Description
Ethernet ports	Ethernet port for EtherNet/IP, Modbus TCP, and web server connections
Input/Output	One configurable channel for mA Output, Frequency Output, or Discrete Output
Power <sup>(1)</sup>	<ul style="list-style-type: none"> <li>▪ One pair of wiring terminals accepts DC power</li> <li>▪ Power over Ethernet PD Classification 3</li> <li>▪ One internal ground lug for power-supply ground wiring</li> </ul>
Sensor	<ul style="list-style-type: none"> <li>▪ Direct mount</li> <li>▪ 9-wire remote mount - 9 terminals for connection to 9-wire sensor</li> </ul>
Universal Service Port (USP)	USB-C connection
Embedded web server	<ul style="list-style-type: none"> <li>▪ Connects to embedded web server via Ethernet connection for on-board configuration or data transfer</li> <li>▪ Supports secure web server connection with default Self-Signed Certificate and optional support for Certificate Authority</li> </ul>

(1) Power connection is not used when Power over Ethernet (PoE) is used.

# Input/output signal detail

## Ethernet channels (output board code C)

Signal	Channel A	Channel B
Channel options	EtherNet/IP ProLink III and the Integrated Web server can always be connected to Channel A	mA Output
	Modbus TCP	Frequency Output
		Discrete Output

## Channel A specifications

### Ethernet (output board code C)

Specifications:

- 10BASE-T
- 100BASE-TX

## Channel B specifications

Specification	mA Output	Frequency Output	Discrete Output
Internal voltage (active power)	Nominal: 24VDC Maximum loop resistance: 820 ohm	Nominal: 24VDC Sourcing: 22 mA	Nominal: 24VDC Sourcing: 7 mA sourcing
External voltage (passive power)	Maximum: 30VDC Maximum loop resistance: 1080 ohm @ 30VDC	Maximum: 30VDC Maximum sinking: 500 mA	Maximum: 30VDC Maximum sinking: 500 mA
Scalable range	4-20mA	0.01 Hz - 10 kHz	
Downscale fault	Configurable from 1.0 - 3.6 mA, default value = 2.0 mA	0Hz	
Upscale fault	Configurable from 21.0 - 23.0 mA, default value = 22.0 mA	Configurable from 10 Hz to 14.5 kHz, default value = 14.5 kHz	
Linearity	0.015 % Span, Span = 16mA	Output is linear with flow rate to 12.5 kHz	
Resolution		± 1 pulse	

## Sensor input mounting codes

Mounting codes	Description
I or H (integral mount)	Integrally mounted to sensor, no external input connection
C (9-wire remote mount)	One 9-wire sensor signal input connection, intrinsically safe

## Digital communications

Protocols	Outputs and descriptions
Modbus/Universal Service Port	<ul style="list-style-type: none"> <li>▪ One service port that can be used for a temporary connection only</li> <li>▪ Supports all Modbus data rates</li> <li>▪ Requires a USB-C to USB-A cable               <ul style="list-style-type: none"> <li>— A 3 ft (0.9 m) cable is supplied with each transmitter</li> </ul> </li> </ul>
EtherNet/IP/Ethernet	<ul style="list-style-type: none"> <li>▪ Available on Channel A</li> <li>▪ Supports Auto Negotiate with data rates of 10 MB and 100 MB and half and full duplex</li> <li>▪ Supports Auto Detect of Ethernet Crossover cables</li> <li>▪ Supports Dynamic Host Configuration Protocol (DHCP)</li> <li>▪ Supports Address Conflict Detection (ACD)</li> <li>▪ Supports Quality of Service (QoS)</li> <li>▪ Supports file object for EDS download</li> <li>▪ Conforms to ODVA EtherNet/IP Specification CT 12</li> <li>▪ Conforms to the 10BASE-T and 100BASE-TX Ethernet standards</li> <li>▪ Supports secure web server connection with default Self-Signed Certificate and optional support for Certificate Authority</li> </ul>



Protocols	Outputs and descriptions
Modbus TCP/Ethernet	<ul style="list-style-type: none"> <li>▪ Available on Channel A</li> <li>▪ Supports Auto Negotiate with data rates of 10 MB and 100 MB and half and full duplex</li> <li>▪ Supports Auto Detect of Ethernet Crossover cables</li> <li>▪ Supports Dynamic Host Configuration Protocol (DHCP)</li> <li>▪ Uses v1.1b of the Modbus TCP standard</li> <li>▪ Conforms to the 10BASE-T and 100BASE-TX Ethernet standards</li> <li>▪ Supports secure web server connection with default Self-Signed Certificate and optional support for Certificate Authority</li> </ul>

## Power supply

- Complies with Low Voltage Directive 2014/35/EU per IEC 61010-1 Ed. 3.0 2010-06; Over voltage Category II, Pollution Degree 2
- Power over Ethernet (PoE) option complies with IEEE 802.3af and 802.3at PoE standards
- For European installations, install a switch or circuit breaker that is suitably located and easily reached. Mark the switch or circuit breaker as the disconnecting device for the transmitter, in compliance with the Low Voltage Directive 2014/35/EU.

Type	Value
DC power	<ul style="list-style-type: none"> <li>▪ 8 to 30 Vdc</li> <li>▪ 3.5 watts typical, 8 watts maximum</li> <li>▪ Size the length and diameter of power conductors to provide 18 VDC minimum at the power terminals at a load current of 0.5A</li> </ul>
Fuse	1.5A Slow Blow (UL 248-14)

### Note

Also accommodates Power over Ethernet (PoE) Class 3 (Power at Device of 6.49 to 12.95 W)

## Environmental limits

### Ambient temperature limits

Type	Temperature
Operating	-40 °F (-40.0 °C) to 149 °F (65.0 °C)
Storage	-40 °F (-40.0 °C) to 185 °F (85.0 °C)

### Note

The display can lose visibility below -22 °F (-30.0 °C).

### Vibration limits

Meets IEC 60068-2-6, endurance sweep, 5 to 2000 Hz up to 1.0 g.

**Humidity limits**

The humidity limits are 5 to 95% relative humidity, non-condensing at 140 °F (60.0 °C).

## Environmental effects

### EMI effects

Complies with:

- EMC directive 2014/30/EU
- NAMUR NE-21 (09.05.2012)

### Ambient temperature effect

Ambient temperature effect on mA Outputs shall not exceed:

Ethernet version	±0.0025% of span per degree C
------------------	-------------------------------

## Hazardous area classifications

### CSA and CSA-US

- Ambient temperature is limited to -40 °F (-40.0 °C) to 149 °F (65.0 °C) for CSA compliance.
- Provides nonincendive sensor outputs for use in Class I, Div. 2, Groups A, B, C, and D.

Code	Description
2A	Class I, Division 2, Groups A, B, C, and D; T5 Class II, Division 2, Groups F, and G; T91°C Class III, Division 2

### IECEX

Ambient temperature range is -40 °F (-40.0 °C) to 149 °F (65.0 °C) for IECEx compliance.

#### Ethernet — Ordering code C

Classification	Approval code	Approval	
Non sparking with an integral transmitter on the sensor	3A	Gas markings	Ex ec nC IIC T5 Gc
		Dust marking	Ex tc IIIC T91 °C Dc IP66/IP67
Non sparking with a remote transmitter on the sensor	3A	Gas markings	Ex ec nC IIC T5 Gc
		Dust marking	Ex tc IIIC °C Dc IP66/IP67

#### IECEX mounting options

Code	Description
3A (integral mounting options)	Used in IECEx EPL Gc/Dc Zone 2/22, non sparking
3A (mounting option C)	Used in IECEx EPL Gc/Dc Zone 2/22, non sparking

## ATEX

Ambient temperature range is -40 °F (-40.0 °C) to 149 °F (65.0 °C) for ATEX compliance.

### Ethernet — Ordering code C

Classification	Approval code	Approval	
Non sparking with an integral transmitter on the sensor	VA	Gas Markings	II 3 G Ex ec nC IIC T5 Gc
		Dust marking	II 3 D Ex tc IIIC T91 °C Dc IP66/IP67
Non sparking with a remote transmitter on the sensor	VA	Gas Markings	II 3 G Ex ec nC IIC T5 Gc
		Dust marking	II 3 D Ex tc IIIC T91 °C Dc IP66/IP67

### ATEX mounting codes

Code	Description
VA (integral mounting options)	Used in ATEX II 3 G/D Zone 2/22 with non-sparking.
VA (remote mounting option C)	Used in ATEX II (2) 3 G/D Zone 2/22, non-sparking.

## Environmental compliance

<p><b>Figure 1: 1600 transmitter battery</b></p> 	<p>The battery in the 1600 transmitter cannot be serviced or replaced by users. In compliance with RoHS (Restriction of Hazardous Substances) and WEEE (Waste Electrical and Electronic Equipment), Micro Motion provides a service for battery replacement and disposal.</p> <p>The 1600 transmitter complies with RoHS Directive 2011/65/EU.</p>
<p>Ingress protection</p>	<p>1600 transmitters contain the following ingress protection for specific transmitters:</p> <ul style="list-style-type: none"> <li>▪ All 1600 transmitters have NEMA 4X protection.</li> <li>▪ 1600H transmitters have IP66/IP67/IP69 protection.</li> <li>▪ 1600I and 1600C transmitters have IP66/IP67 protection.</li> </ul>

## Physical specifications

For transmitters integrally mounted to a sensor, you may need to add the weight of the transmitter to the sensor. Refer to the Sensor Product Data Sheet.

### Materials of construction

Depending on the specific model number ordered, 10 ft (3 m) of shielded 9-wire PVC cable will be included. For more details, see Ordering information. For longer cable lengths, contact customer support.

Specification	Value		
Housing	<ul style="list-style-type: none"> <li>■ Polyurethane-painted cast aluminum</li> <li>■ Hygienic 316 stainless steel</li> </ul>		
Weight	<ul style="list-style-type: none"> <li>■ Painted aluminum 9 wire remote: 5.1 lb (2.31 kg)</li> <li>■ Painted aluminum integral: 2.5 lb (1.13 kg)</li> <li>■ Stainless steel integral: 5.3 lb (2.40 kg)</li> </ul>		
Terminal compartments	Output terminals are physically separated from the power and service-port terminals		
Cable gland entrances	<ul style="list-style-type: none"> <li>■ 9-wire remote: ¾ in. – 14 NPT female conduit port for sensor cable.</li> <li>■ For power and I/O, M20 x 1.5 female, or ½ in. - 14 NPT conduit entries are available.</li> </ul>		
Optional M12 connections	<ul style="list-style-type: none"> <li>■ Pre-installed M12 quick connections available as an option</li> <li>■ Option of (1) pre-installed for Ethernet connections and an option for additional (1) connection for power and configurable output</li> <li>■ Only available with M20 conduit connection (no gland)</li> </ul>		
Mounting	<ul style="list-style-type: none"> <li>■ Integral or remote mounting options (available only for remote installations)</li> <li>■ Remote mount aluminum housing version includes two U-bolts for installing the transmitter on a pipe</li> <li>■ For remote 9-wire mounts, the transmitter can be rotated 360 degrees with respect to customer pipe in 90-degree increments</li> <li>■ For integral mount, the transmitter can be rotated with respect to the sensor in 45-degree increments</li> </ul>		
Maximum cable lengths between sensor and transmitter <sup>(1)</sup>	Cable type	Wire gauge	Maximum length
	Micro Motion 9-wire	Not applicable	1,000 ft (305 m) <sup>(2)</sup>
Standard interface/display	<ul style="list-style-type: none"> <li>■ Graphical backlit display with 4-button optical controls and flow meter-status LED</li> <li>■ Depending on purchase option, transmitter housing cover has either a polycarbonate cover or tempered glass lens option</li> <li>■ To facilitate various mounting orientations, the display can be rotated, through software, in 90-degree increments</li> <li>■ Display supports English, German, French, Spanish, Portuguese, Chinese, and Japanese</li> </ul>		

Specification	Value
Display functions	<ul style="list-style-type: none"> <li>■ Complete operation and configuration through the display, no service tool required</li> <li>■ View process variables</li> <li>■ Start, stop, and reset totalizers</li> <li>■ View and acknowledge alarms</li> <li>■ View the Smart Meter Verification initiation and results from the display without interrupting process measurement</li> <li>■ Set the flow meter to zero, simulate outputs, change measurement units, configure outputs, and set RS-485 communications options</li> <li>■ View a three-color LED status light on display panel that indicates flow meter conditions at a glance</li> </ul>

- (1) For the cable sizing formula, see the appropriate Micro Motion 1600 installation manual.  
 (2) For Smart Meter Verification, the limit is 66 ft. (20 m)

## Dimensions

Figure 2: Remote mount transmitter

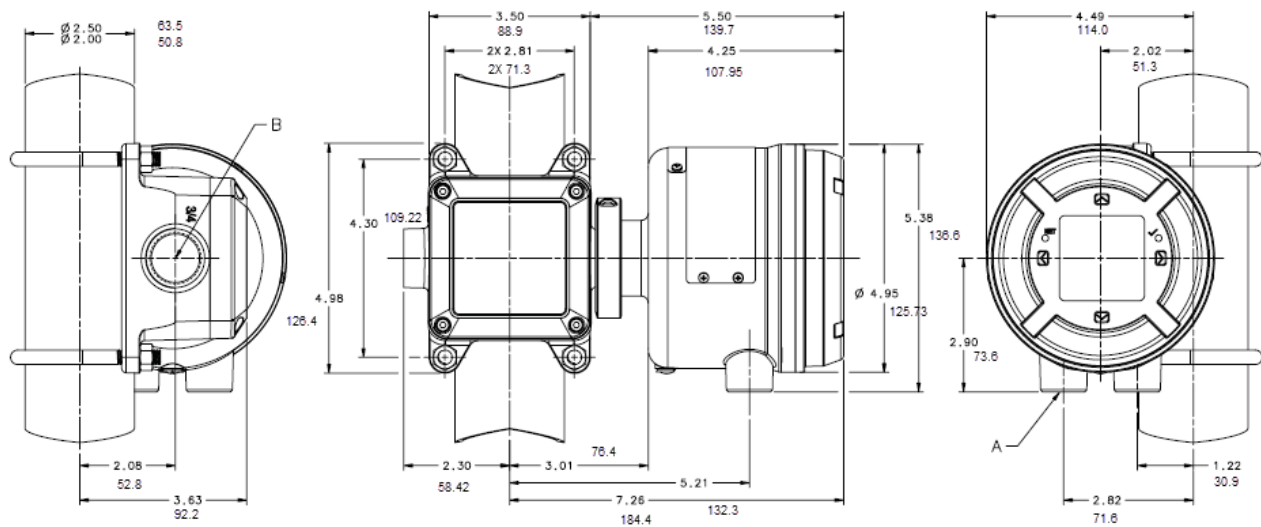

**Note**

Measurements are in inches (millimeters).

Figure 3: Integral mount transmitter

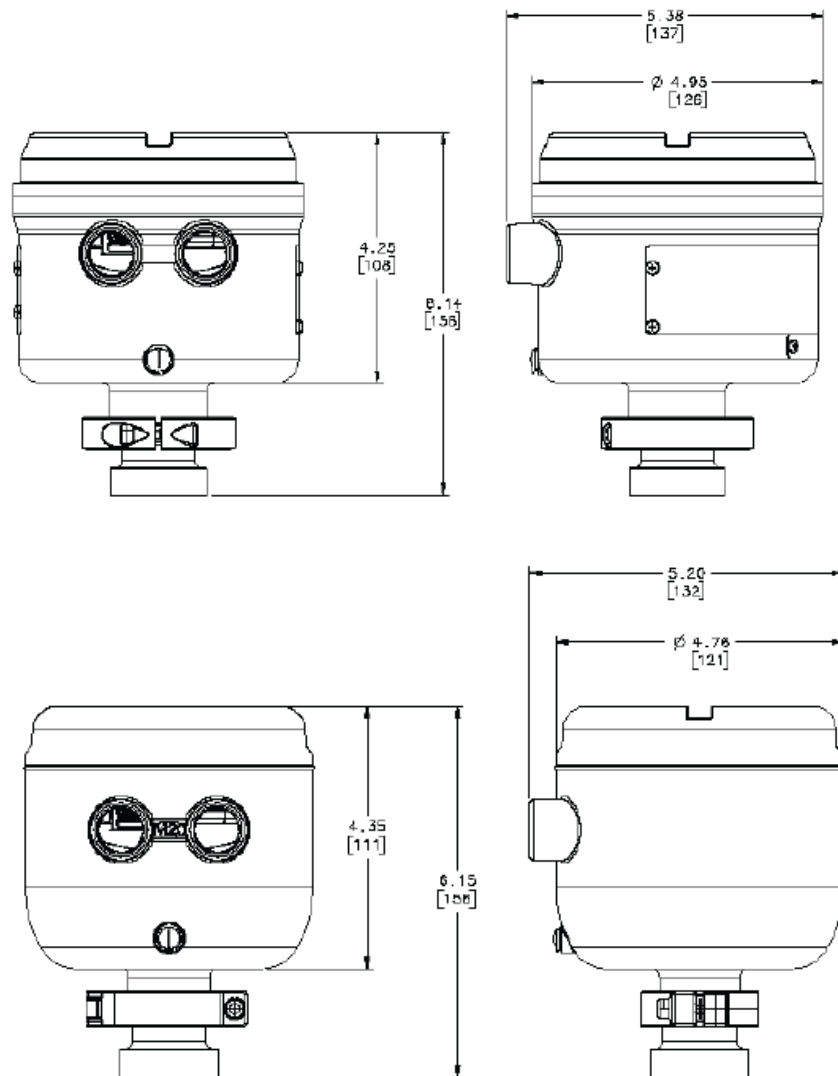

**Note**

Measurements are in inches [millimeters].

Figure 4: Integral mount transmitter with retrofit adapter

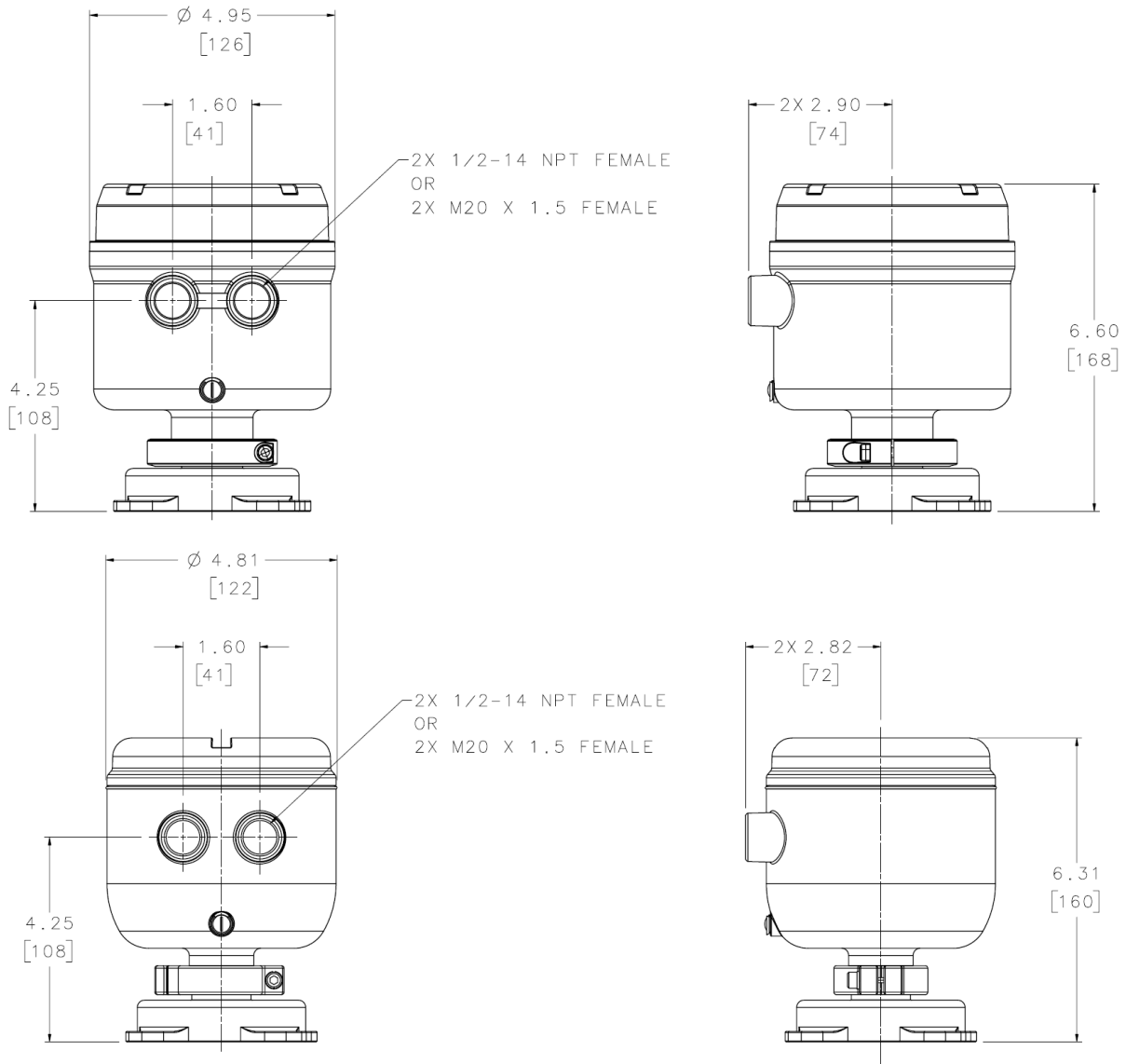

**Note**  
Measurements are in inches [millimeters].

## Ordering information

### Model

Model	Product description
1600	Micro Motion 1600 compact transmitter

## Mounting options

Code	Description
I	Integral mount transmitter (polyurethane-painted aluminum housing)
C	9-wire remote transmitter (polyurethane-painted aluminum housing) bracket for pipe mounting and hardware for 2 in (51 mm) pipe mount. Includes 10 ft (3 m) 9 wire CFEPS cable.
H	Integral mount transmitter (hygienic, 316 stainless steel housing)
S <sup>(1)(2)</sup>	Integral mount transmitter retrofit to existing sensor replacing 1700/2700 integral mount transmitter (polyurethane-painted aluminum housing)
T <sup>(1)(2)</sup>	Integral mount transmitter retrofit to existing sensor replacing 1700/2700 integral mount transmitter (hygienic, 316 stainless steel housing)

(1) *Compatible with sensors that include a 700 standard core.*

(2) *Not available with add on option MV.*

## Power options

### Available with output hardware board code C

Code	Description
2	18 to 30 VDC and Power over Ethernet (PoE) capability; automatic detection

## Display options

### Available with housing code I and C

Code	Description
1	Glass backlit graphic display

### Available with all housing codes

Code	Description
3	No display
4	Non-glass backlit graphic display with engineered-polymer cover

## Output hardware board

Code	Description
C	Ethernet outputs Select either EtherNet/IP or Modbus TCP in <a href="#">Output channel assignments</a>



## Conduit connection options

Code	Description
B	½ in. NPT — no gland
C	½ in. NPT with brass/nickel cable gland
D	½ in. NPT with stainless steel cable gland
E	M20 — no gland
F	M20 with brass/nickel cable gland
G	M20 with stainless steel cable gland

## Approval options

Code	Description
MA	Micro Motion Standard (no approval)
5A	Quad-Label Approval. Includes the following Approvals on the same label: CSA (US and Canada): Class I, Div. 2, ATEX and UKCA: II 3G, Ex ec, Zone 2 and II 3D Ex tc Zone 2, and IECEx: EPL Gc, Ex ec, Zone 2
2A <sup>(1)</sup>	CSA (US and Canada): Class I, Division 2
VA <sup>(1)</sup>	ATEX: II 3G, Ex ec, Zone 2 and II 3D Ex tc Zone 2
3A <sup>(1)</sup>	IECEx: EPL Gc, Ex ec, Zone 2

(1) *Sensor connections will be intrinsically safe without an additional barrier in safe areas only.*

## Revision

Code	Description
A	Revision A

## Transmitter option 1

Code	Description
Z	Standard product

## Transmitter option 2

Code	Description
Z	Standard product

## Factory options

Code	Description
Z	Standard product
X	ETO product

## Output channel assignments

### Channel A

**Channel A: Available with output board code C**

Code	Description
C	EtherNet/IP
D	Modbus TCP

### Channel B

**Channel B: Available with output board code C**

Code	Description
Z	Channel Off
C	Channel On — configurable to mA Output, Frequency Output, and Discrete Output

## Additional features

All of the following additional features are optional.

### Instrument Tagging

Code	Description
TG	Instrument Tagging — customer information required (maximum 24 characters)

### Note

The model code on the hazard area approval tag does not include any optional additional features. To show the complete model code (including optional additional features), the TG option is required and you must specify the information at time of order.

### Smart Meter Verification

Code	Description
MV <sup>(1)(2)</sup>	Smart Meter Verification Professional

(1) Mounting option C is limited to 60 ft (18.29 m) of 9-wire cable and only available when purchased with new 9-wire sensor.

(2) Not available with mounting options S or T.

**Enhanced measurement**

Select only one of the following codes:

Code	Description
PS	API referral software
CM	Concentration measurement software

**Advanced Phase Measurement**

Select any of the following feature codes:

Code	Description
PG	Advanced Phase Measurement gas with liquid
PL	Advanced Phase Measurement liquid with gas
MA <sup>(1)</sup>	Manual Advanced Phase Measurement configuration

(1) Not available with add on option PL.

**Additional software options**

Select only one of the following feature codes.

Code	Description
BS <sup>(1)</sup>	Batching Software
FF <sup>(1)</sup>	Fast Fill Software

(1) Only available with Channel B ON.

**Historian**

Code	Description
HS	Historian with Real Time Clock

**Ethernet conduit electrical connectors**

Requires output hardware board code C. Select only one of the following codes:

Code	Description
CA <sup>(1)</sup>	(1) M12 connector for Ethernet port
CB <sup>(1)</sup>	(1) M12 connector for Ethernet port and (1) M12 connector for Channel B and power

(1) Only available with conduit connection option E.

For more information: [Emerson.com/global](https://emerson.com/global)

©2024 Micro Motion, Inc. All rights reserved.

The Emerson logo is a trademark and service mark of Emerson Electric Co. Micro Motion, ELITE, ProLink, MVD and MVD Direct Connect marks are marks of one of the Emerson Automation Solutions family of companies. All other marks are property of their respective owners.