

# Control Valve compact 8028



With integrated positioner  
GS1 Series - DN15 up to DN150

**Pneumatic manual control valve for the control of neutral through to highly aggressive media in process engineering, chemical industries and for plant equipment.**

- Excellent control precision due to less friction at the actuator
- High rangeability of 40:1 linear / 80:1 equal percentage
- Control of high differential pressures with small actuators
- Without positioner also suitable for on/off applications
- Space saving wafer type construction
- Integrated positioner
- Lowest possible weight
- Quiet operation
- Fast response time
- Greatly reduced energy consumption rates due to short strokes and low actuating forces on the throttle elements
- Meets the requirements of TA-Luft 2021

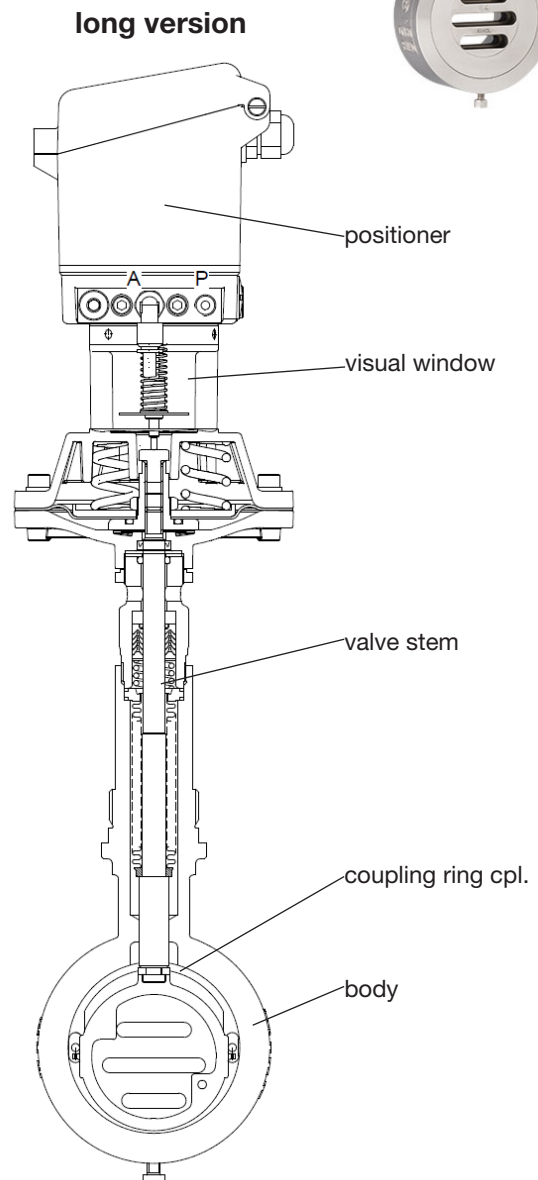
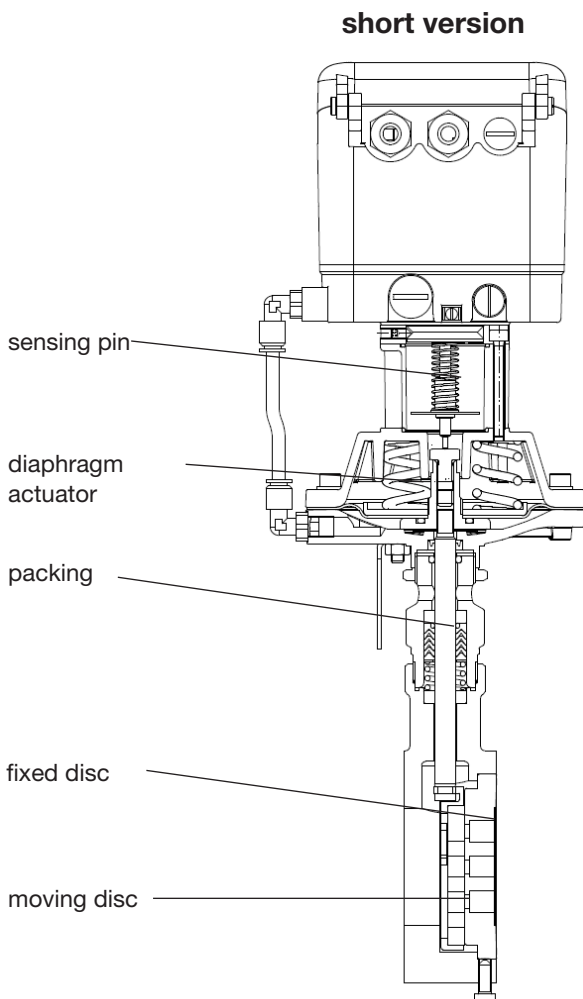

## Technical information

Body design	flangeless, wafer-type construction dimensions acc. DIN EN 558-1 series 20 for flanges acc. DIN EN 1092-1, form B more versions see data-sheet 8028-GS3		
Nominal size	DN 15 to DN 150		
Nominal pressure	PN 40 acc. DIN 2401 (also for flanges PN 10 to PN 25)		
Fluid temperature	carbon steel body	-10°C to +350°C	
	stainless steel body	-60°C to +350°C	
	body (short version)	up to max. +230°C	
Flange gaskets (customer side)	DIN EN 1514-1 or ANSI B16.21 in the respective nominal pressure rating		
Ambient temperature*	-30°C up to +100°C		
Rangeability / Characteristic digital positioner	40 : 1 linear / 80 : 1 equal percentage		
Leakage	Disc Pair	Disc Pair	Disc Pair
	Carbon-stainless steel	SFC	STN2
% of Kvs	<0,0001	<0,0005	<0,001
IEC 60534-4	IV-S1	IV-S1	IV
EN 12266-1	E	F	F
Specific leakage rate shaft and body sealing	ISO FE - BH - CC3 - SSA0 - t (-40°C / +350 °C) - PN40 - ISO 15848-1		

## Materials

Body	Carbon steel 1.0619	Stainless steel 1.4408
Diaphragm housing	Aluminium, KTL- coated	
Actuator springs	Stainless steel 1.4310	
Packing	PTFE carbon filled (spring 1.4310)	
Actuating stem	Stainless steel 1.4571, roller burnished	
Bellows (optional)	Stainless steel 1.4571	
Fixed disc	Stainless steel 1.4571 coated	STN2 - disc
Sliding disc	Special carbon material	SFC - disc (max. 300°C) STN2 - disc
Coupling ring for disc	Stainless steel 1.4581	
Positioner Housing	Aluminium anodized, synthetic	

## Admissible Differential Pressure

DN	Disc pair carbon/SFC-stainless steel coatet		DN	STN2-disc pair	
	max. working pressure (bar)	required pilot pressure (bar)		max. working pressure (bar)	required pilot pressure (bar)
15	40	3,5	15	40	3,5
20	40	3,5	20	40	3,7
25	40	3,5	25	32	4
32	40	3,6	32	23	4,3
40	35	4,0	40	16	4,5
50	23	4,8	50	9,7	5,2
65	19,5	4,9	65	8	5,2
80	12	5,1	80	4,8	5,3
100	7,9	5,3	100	3	5,5
125	5,3	5,4	125	2	5,5
150	4	5,4	150	1,4	5,5

## Applications limits for GS1-Valves

PN 40	Sliding unit: carbon/SFC - stainless steel, coated max. admissible pressures for GS1-valves						Sliding unit: carbon - STN2 max. admissible pressures for GS1-valves					
	100°C	150°C	200°C	250°C	300°C	350°C	100°C	150°C	200°C	250°C	300°C	350°C
15 - 25	40	36	31	28	26	24	40	36	31	28	26	24
32	40	36	31	28	26	24	40	36	31	28	25	22
40	40	36	31	28	26	24	27	26	24	19,5	16	14
50	40	36	31	28	26	24	40	36	31	28	26	24
65	40	36	31	28	26	24	38	36	31	28	23	19,5
80	40	36	31	28	26	24	22	21	20	16	13	11,5
100	25	24	22	19	16	14,5	13,5	12,5	12,0	9,8	8,1	7,0
125	16,5	15,5	15	12,5	10,5	9,5	8,9	8,4	8,0	6,5	5,3	4,6
150	16	16	16	16	13	11,5	11	10,5	9,8	7,9	6,5	5,6

Limitation for SFC-sliding discs: 300°C



## Dimensions and weight - short version with digital positioner 8049

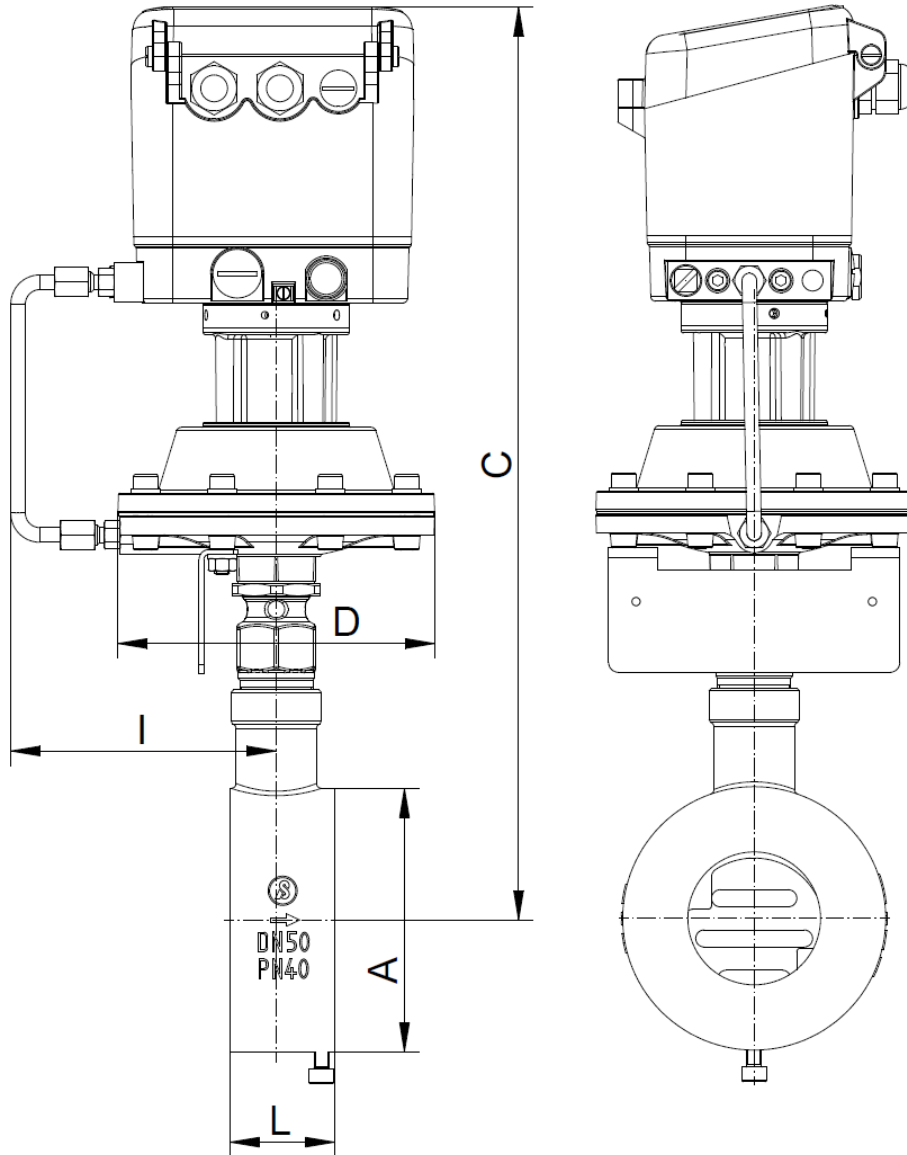

DN	A	C carbon steel body	C stainless steel body	D	I	L	Stroke H	Weight (kg)
15	53	356	359	130	114	33	6	3,7
20	62	361	364	130	114	33	6	3,8
25	72	366	369	130	114	33	6	3,9
32	82	369	372	130	114	33	6	3,9
40	92	374	377	130	114	33	6	4,1
50	108	375	400	130	114	43	8	5,2
65	126	384	410	130	114	46	8	5,7
80	142	392	418	130	114	46	8	6,4
100	164	405	430	130	114	52	8,5	7,6
125	194	418	443	130	114	56	8,5	11,3
150	219	439	465	130	114	56	8,5	13,2

dimensions in mm

# Control Valve compact - GS1

## Dimensions and weight - short version, On- / Off- Valve

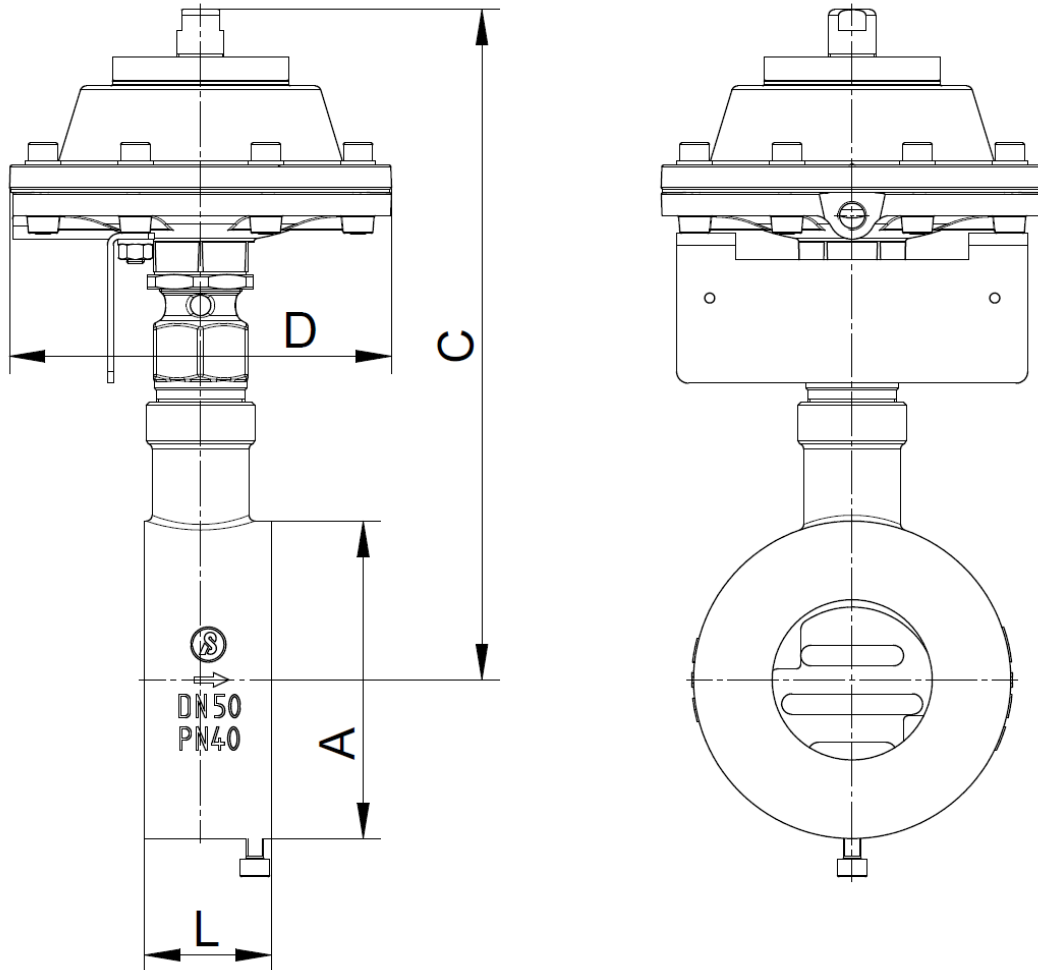

DN	A	C carbon steel body	C stainless steel body	D	L	Stroke H	Weight (kg)
15	53	209	212	130	33	6	3,7
20	62	214	217	130	33	6	3,8
25	72	219	222	130	33	6	3,9
32	82	222	372	130	33	6	3,9
40	92	227	225	130	33	6	4,1
50	108	228	253	130	43	8	5,2
65	126	237	263	130	46	8	5,7
80	142	245	271	130	46	8	6,4
100	164	258	283	130	52	8,5	7,6
125	194	271	296	130	56	8,5	11,3
150	219	192	318	130	56	8,5	13,2

dimensions in mm

## Dimensions and weight - long version with digital positioner 8049

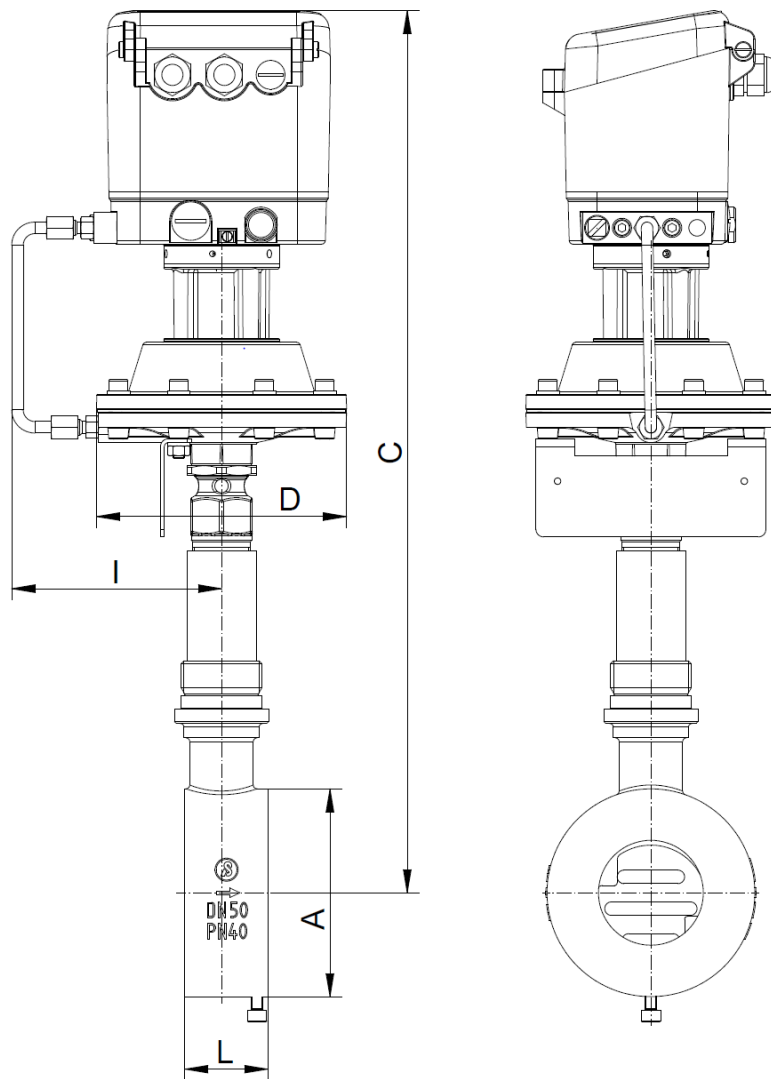

DN	A	C	D	I	L	Stroke H	Weight (kg)
15	53	430	130	114	33	6	3,7
20	62	437	130	114	33	6	3,8
25	72	440	130	114	33	6	3,9
32	82	445	130	114	33	6	3,9
40	92	450	130	114	33	6	4,1
50	108	459	130	114	43	8	5,2
65	126	468	130	114	46	8	5,7
80	142	477	130	114	46	8	6,4
100	164	490	130	114	52	8,5	7,6
125	194	502	130	114	56	8,5	11,3
150	219	520	130	114	56	8,5	13,2

dimensions in mm

## Dimensions and weight - long version, On- / Off- Valve

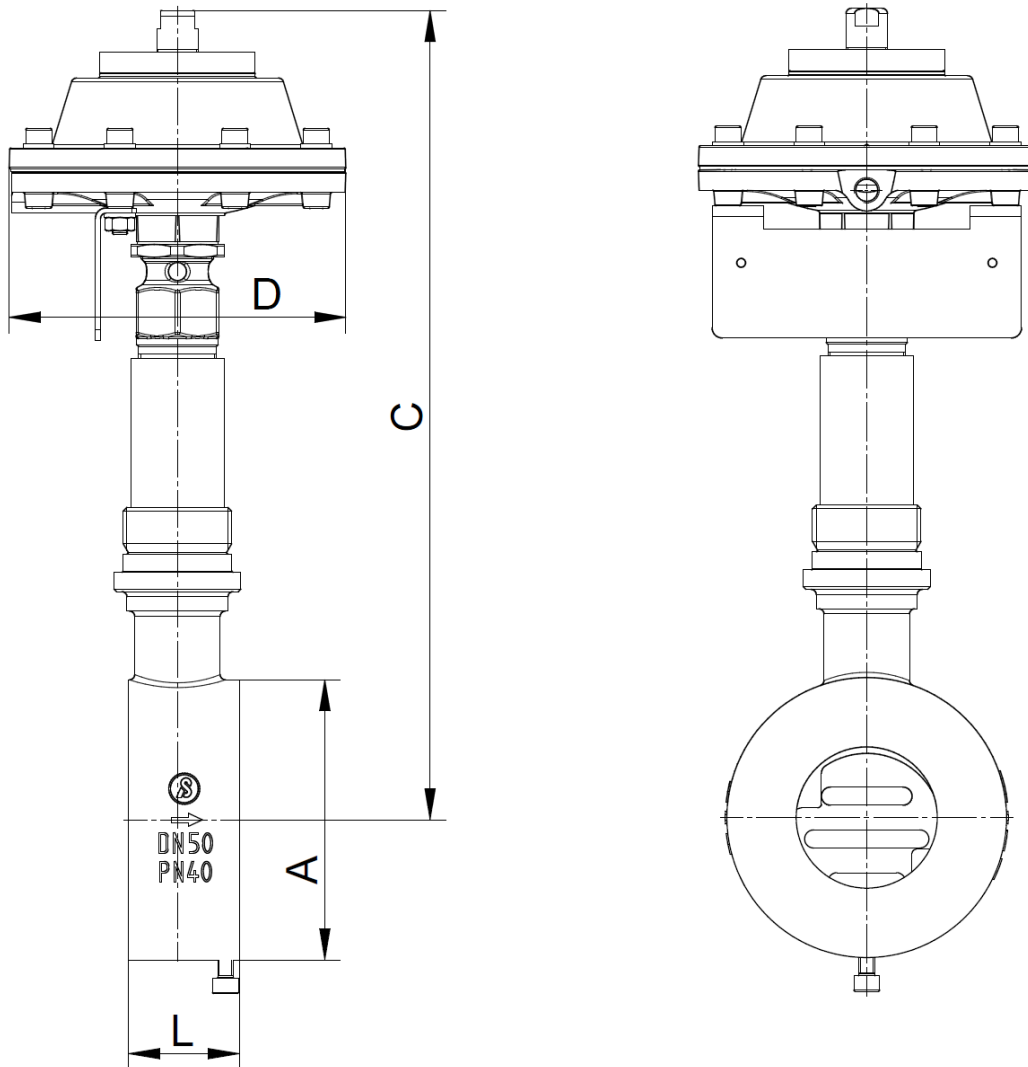

DN	A	C	D	L	Stroke H	Weight (kg)
15	53	283	130	33	6	2,7
20	62	290	130	33	6	2,8
25	72	293	130	33	6	2,9
32	82	298	130	33	6	2,9
40	92	303	130	33	6	3,1
50	108	312	130	43	8	4,2
65	126	321	130	46	8	4,7
80	142	330	130	46	8	5,4
100	164	343	130	52	8,5	6,6
125	194	355	130	56	8,5	10,3
150	219	373	130	56	8,5	12,2

dimensions in mm