

Control Valve 8021

with integrated positioner

GS 3 series - DN 15 up to DN 250

Pneumatic control valve for the control of neutral and aggressive fluids with integrated positioner

- Space saving wafer type construction
- Lowest possible weight
- Quiet operation
- Fast response time
- Control of high differential pressures with small actuators
- Greatly reduced energy consumption rates due to short strokes and low actuating forces on the throttle element
- High Kvs-values
- Meets the requirements of TA-Luft 2021



Technical Information

Design	wafer-type design for flanges acc. DIN EN 1092-1 Form B or ASME B16.5 RF further versions see data sheet 8021-GS1		
Nominal Sizes	DN 15 - 250, 1/2" - 12"		
Nominal pressure acc. EN 1333	PN 40 (fits also to PN10-PN25) PN 100 PN 16	DN 15 - DN 150 DN 15 - DN 80 DN 200 - DN 250	
Nominal pressure acc. ANSI	ANSI 150 ANSI 300 ANSI 600	DN15 - DN 250 DN 15 - DN 150 DN 15 - DN 80	
Nominal pressure acc. JIS for flanges with raised face	10K 20K	DN 15 - DN 50 DN 15 - DN 40	
Fluid Temperature	Versions from -60°C up to 350°C		
Ambient temperature*	-30°C up to +100°C		
Flange gaskets (customer side)	DIN EN 1514-1 or ANSI B16.21 in the respective nominal pressure rating		
Rangeability / Characteristic analog positioner digital positioner	30 : 1 40 : 1 linear / 80 : 1 equal percentage		
Leakage	Disc pair Carbon-stainless steel	Disc pair SFC	Disc pair STN 2
% of Kvs IEC 60534-4 EN 12266-1	< 0,0001 IV-S1 E	< 0,0005 IV-S1 F	< 0,001 IV F
Specific leakage rate shaft and body sealing	ISO FE-BH-CC3-SSA0-t(-40°C/+350°C)-PN40-ISO 15848-1		
Marking ATEX non electric	II 2G Ex h IIC T6...T1 X Gb II 2D Ex h IIIC 85°C...530°C X Db		
Applications acc. PED 2014/68/EU	stainless steel or carbon steel body body made of Alloy C-276	up to category II up to category I	

* Please consider the limitation of use of the positioner!

** With DN15 with reduction of less than 25%, different leakage rates possible.

Kvs-values see data sheet 8001

Fluid temperature

Rating	PN40	PN 16	PN 100	ANSI 150	ANSI 300	ANSI 600
Body material cpl. stainless steel						
Tmin [°C]	-60	-60	-60	-29	-29	-29
Tmax [°C]	350	350	350	350	350	350
Body material carbon steel with stainless steel body cover						
Tmin [°C]	-60	-60	-10	-20	-20	-20
Tmax [°C]	350	350	350	350	350	350
Body material Alloy C-276						
Tmin [°C]	-60	-60	-60	-29	-29	-29
Tmax [°C]	350	350	350	350	350	350

Positioner

For technical information of our positioners please refer to the corresponding data sheets.

Control Valve 8021-GS3



with integrated positioner

Material

Stainless steel version			
Valve body	stainless steel, 1.4408		
Bodycover	stainless steel, 1.4404 or 316L		
Valve stem	stainless steel 1.4571, roller burnished		
coupling ring	Stainless steel 1.4581		
Packing tube	Stainless steel 1.4408		
Packing	PTFE carbon filled (spring 1.4310)		
Body seal	Graphite with stainless steel foil		
Fixed disc	stainless steel coated	STN2-disc	STN3-disc
Sliding disc	special carbon material	SFC-disc (max. +300°C)	STN2-disc

carbon steel version			
Valve body	carbon steel, 1.0619		
Bodycover	stainless steel, 1.4404 or 316L		
Valve stem	stainless steel 1.4571, roller burnished		
coupling ring	Stainless steel 1.4581		
Packing tube	Stainless steel 1.4408		
Packing	PTFE carbon filled (spring 1.4310)		
Body seal	Graphite with stainless steel foil		
Fixed disc	stainless steel coated	STN2-disc	STN3-disc
Sliding disc	special carbon material	SFC-disc (max. +300°C)	STN2-disc

Version in Alloy C-276			
Valve body	Alloy C-276, 2.4819		
Bodycover	Alloy C-276, 2.4819		
Valve stem	Alloy C-276, 2.4819		
coupling ring	Alloy C-276, 2.4819		
Packing tube	Alloy C-276, 2.4819		
Packing	PTFE carbon filled (spring Alloy C4, 2.4610)		
Body seal	Pure graphite		
Fixed disc	Alloy C-276, 2.4819		STN3-disc
Sliding disc	special carbon material		STN3-disc

For all versions	
Diaphragm casing	aluminium, KTL-coated or stainless steel
Actuator springs	stainless steel 1.4310
Coupling	zinc die-cast or stainless steel
Mounting parts	stainless steel

Limitations for valves made of Alloy C-276

Additionally to the limitations of the pressure rating valves made of Alloy C-276 are limited to applications of the category I of the PED 2014/68/EU

		maximum admissible operating pressure in bar for application of category I of the pressure equipment directive 2014/68/EU				
		DN15	DN25	DN40	DN50	DN80
Fluid groupe 1	gaseous	X	X	25	20	12,5
	liquid	X	X	50	40	25
Fluid groupe 2	gaseous	X	X	X	X	X
	liquid	X	X	X	X	X

X = no limitation

Control Valve 8021-GS3

with integrated digital positioner, Type 8049

(also on-off valves and valves with other side-mounted positioner)



Admissible differential pressures

(For temperatures of up to 120°C with PN-rating up to 38°C with ANSI-rating)

For temperatures of 120°C (PN) or 38°C (ANSI) and above: obey application limits!

Disc pair:

**Carbon - stainless steel coated /
SFC - stainless steel coated /
Carbon - Alloy C-276**

Actuator Size	125 cm ²		250 cm ²		500 cm ²	
	4,5	5,5	3,0	4,0	3,0	4,5
Supply air (bar)						
DN	max. admissible differential pressure (bar)					
15 **	102,1	102,1	102,1	102,1	-	-
20	102,1	102,1	102,1	102,1	-	-
25 **	88 (102,1)*	88 (102,1)*	88 (102,1)*	88 (102,1)*	-	-
32	88	102,1	102,1	102,1	-	-
40 **	67	83	88 (102,1)*	88 (102,1)*	-	-
50 **	44	54	75	91	102,1	102,1
65	37	45	63	76	80	80
80 **	23	29	40	48	48	48
100	15	16	25	31	33	33
125	10	11	17	21	23	23
150	7	8	13	15	16	16
200	4	5	7	9	15	16
250	2,7	3,4	4,6	5,6	9,5	10,5
Spring Configuration	Code 3 (Standard)	Code 4	Code 3 (Standard)	Code 4	Code 6 (Standard)	Code 8

Standard

* Values in brackets for valves made of carbon steel or Alloy C-276

** Size available in Alloy C-276 version

Disc pair:

STN 2 / STN 3

Actuator size	125 cm ²		250 cm ²		500 cm ²	
	4,5	5,5	3,0	4,0	3,0	4,5
Supply air (bar)						
DN	max. admissible differential pressure (bar)					
15 **	102,1	102,1	102,1	102,1	-	-
20	81	102,1	102,1	102,1	-	-
25 **	60	75	88 (102,1)*	88 (102,1)*	88 (102,1)*	88 (102,1)*
32	45	56	77	93	102,1	102,1
40	31	38	53	64	72	72
50 **	18	22	31	38	64	77
65	15	18	26	31	53	62
80	9	10	15	19	32	36
100	5	6	9	11	19	23
125	3	4	6	7	13	16
150	2	3	4	5	9	11
200	-	-	-	-	-	-
Spring Configuration	Code 3 (Standard)	Code 4	Code 3 (Standard)	Code 4	Code 6 (Standard)	Code 8

Standard

* Values in brackets for valves made of carbon steel or Alloy C-276

** Size available in Alloy C-276 version

Upper limits of the pressure rating

	Upper limits for admissible pressures in bar					
	PN16	PN40	PN100	ANSI150	ANSI 300	ANSI 600
P max. carbon steel/ Alloy C-276	16	40	100	19,6	51,1	102,1
P max. stainless steel				19,0	49,6	99,3

Control Valve 8021-GS3



with integrated p/p and i/p - positioner, Type 8047

Admissible differential pressures
(For temperatures of up to 120°C with PN-rating
up to 38°C with ANSI-rating)

**For temperatures of 120°C (PN) or
38°C (ANSI) and above:
obey application limits!**

Disc pair:
Carbon - stainless steel coated /
SFC - stainless steel coated /
Carbon - Alloy C-276

Actuator size	125 cm ²				250 cm ²				500 cm ²			
	1,5 up to 3,0		1,8 up to 3,8		1,2 up to 2,2		1,5 up to 2,7		1,2 up to 2,2		1,5 up to 2,7	
Spring range (bar)	1,5 up to 3,0		1,8 up to 3,8		1,2 up to 2,2		1,5 up to 2,7		1,2 up to 2,2		1,5 up to 2,7	
Supply air (bar)	4		5		3		4		3		4,5	
max. admissible differential pressure (bar)												
DN	Control	On-Off	Control	On-Off	Control	On-Off	Control	On-Off	Control	On-Off	Control	On-Off
15**	102	102	102	102	102	102	102	102	-	-	-	-
20	77	77	96	96	102	102	102	102	-	-	-	-
25**	57	57	71	71	88 (98)*	88 (98)*	88 (102,1)*	88 (102,1)*	88 (102,1)*	88 (102,1)*	88 (102,1)*	88 (102,1)*
32	42	42	52	58	73	73	88	88	102	102	102	102
40**	29	29	36	44	49	49	60	60	88 (102,1)*	88 (102,1)*	88 (102,1)*	88 (102,1)*
50**	17	19	21	29	29	29	35	40	60	60	72	72
65	14	16	17	24	24	24	29	34	49	49	59	59
80**	8	10	10	15	14	14	17	22	29	29	35	44
100	5	6	6	10	9	9	10	14	18	18	22	28
125	3	4	4	6	6	6	7	9	12	12	14	19
150	2	3	3	5	4	4	5	7	9	9	10	14
200	2	2	2	3	3	3	3	4	5	5	6	8
250	0,9	1,1	1,1	1,8	1,5	1,5	1,9	2,5	3,2	3,2	3,8	5,2
Spring Configuration	Code 3 (Standard)		Code 4		Code 3 (Standard)		Code 4		Code 3 (Standard)		Code 4	

Standard

- * Values in brackets for valves made of carbon steel or Alloy C-276
- ** Size available in Alloy C-276 version

Upper limits of the pressure rating

	Upper limits for admissible pressures in bar					
	PN16	PN40	PN100	ANSI150	ANSI 300	ANSI 600
P max. carbon steel/ Alloy C-276	16	40	100	19,6	51,1	102,1
P max. stainless steel				19,0	49,6	99,3

Control Valve 8021-GS3



with integrated p/p and i/p - positioner, Type 8047

Admissible differential pressures
(For temperatures of up to 120°C with PN-rating
up to 38°C with ANSI-rating)

**For temperatures of 120°C (PN) or
38°C (ANSI) and above:
obey application limits!**

**Disc pair:
STN 2 / STN 3**

Actuator Size	125 cm ²				250 cm ²				500 cm ²			
Spring Range (bar)	1,5 to 3,0		1,8 to 3,8		1,2 to 2,2		1,5 to 2,7		1,2 to 2,2		1,5 to 2,7	
Supply air (bar)	4		5		3		4		3		4,5	
max. admissible differential pressure (bar)												
DN	Control	On-Off	Control	On-Off	Control	On-Off	Control	On-Off	Control	On-Off	Control	On-Off
15**	55	55	68	70	95	95	102,1	102,1	102,1	102,1	102,1	102,1
20	37	37	46	53	64	64	78	78	102,1	102,1	102,1	102,1
25**	25	26	31	40	43	43	53	55	88 (89)*	88 (89)*	88 (102,1)*	88 (102,1)*
32	17	19	22	30	30	30	36	40	62	62	75	80
40	11	13	14	20	19	19	24	27	40	40	48	58
50**	6	8	8	12	11	11	13	17	23	23	27	35
65	5	6	6	10	9	9	11	14	18	18	22	28
80**	3	4	4	6	5	5	6	8	11	11	13	17
100	2	2	2	3	3	3	4	5	6	6	8	10
125	-	-	2	2	2	2	3	4	4	4	5	7
150	-	-	1	2	2	2	2	3	3	3	4	5
200	-	-	-	-	-	-	-	-	-	-	-	-
Spring Configuration	Code 3 (Standard)		Code 4		Code 3 (Standard)		Code 4		Code 6 (Standard)		Code 6	

Standard

- * Values in brackets for valves made of carbon steel or Alloy C-276
- ** Size available in Alloy C-276 version

Upper limits of the pressure rating

	Upper limits for admissible pressures in bar					
	PN16	PN40	PN100	ANSI150	ANSI 300	ANSI 600
P max. carbon steel/ Alloy C-276	16	40	100	19,6	51,1	102,1
P max. stainless steel				19,0	49,6	99,3

Control Valve 8021-GS3



with integrated positioner

Application limitations for GS3 valves in stainless steel

These pressure must not be exceeded for GS-valves from the GS3-series made of stainless steel, even though the actuator power might allow it.

PN40

DN DN	Sliding unit: carbon/SFC - stainless steel, coated						Sliding unit: STN2					
	max. admissible pressures for GS3-valves in stainless steel						max. admissible pressures for GS3-valves in stainless steel					
	100°C	150°C	200°C	250°C	300°C	350°C	100°C	150°C	200°C	250°C	300°C	350°C
15-32	40	40	40	40	40	40	40	40	40	40	40	40
40	40	40	40	40	40	40	40	40	40	40	37	37
50	40	40	40	40	40	40	40	40	40	40	40	40
65	40	40	40	40	40	40	40	40	40	37	32	32
80	40	40	40	40	40	40	40	40	40	36	34	19
100	33	33	33	33	33	33	33	33	33	32	31	17
125	23	23	23	23	23	23	23	23	23	21	21	11
150	16	16	16	16	16	16	16	16	16	15	15	8
200 (only PN16)	16	16	15	13	12	11	-	-	-	-	-	-
250 (only PN16)	10	9	9	8	7	6	-	-	-	-	-	-

Limitation for SFC-sliding discs: 300°C

PN100

DN DN	Sliding unit: carbon/SFC - stainless steel, coated						Sliding unit: STN2					
	max. admissible pressures for GS3-valves in stainless steel						max. admissible pressures for GS3-valves in stainless steel					
	100°C	150°C	200°C	250°C	300°C	350°C	100°C	150°C	200°C	250°C	300°C	350°C
15	100	100	100	93	84	79	100	100	100	93	84	79
20	100	100	89	81	73	68	100	100	89	81	73	68
25	88	81	70	63	57	54	88	81	70	63	57	54
32	100	93	80	73	65	62	100	93	80	73	65	60
40	88	81	70	63	57	54	72	69	65	53	43	37
50	100	100	100	100	100	94	77	73	70	56	46	40
65	80	80	80	79	71	67	62	59	56	45	37	32
80	48	48	48	48	48	44	36	34	33	26	22	19

Limitation for SFC-sliding discs: 300°C

ANSI150

DN	Sliding unit: carbon/SFC - stainless steel, coated								Sliding unit: STN2							
	max. admissible pressures for GS3-valves in stainless steel								max. admissible pressures for GS3-valves in stainless steel							
	38°C	50°C	100°C	150°C	200°C	250°C	300°C	350°C	38°C	50°C	100°C	150°C	200°C	250°C	300°C	350°C
15-125	19,0	18,4	16,2	14,8	13,7	12,1	10,2	8,4	19,0	18,4	16,2	14,8	13,7	12,1	10,2	8,4
150	16,0	16,0	16,0	14,8	13,7	12,1	10,2	8,4	16,2	16,2	16,2	14,8	13,7	11,8	9,7	8,4
200	16,0	16,0	16,0	14,8	13,7	12,1	10,2	8,4	-	-	-	-	-	-	-	-
250	10,4	10,4	10,4	9,9	9,4	8,4	7,4	6,8	-	-	-	-	-	-	-	-

Limitation for SFC-sliding discs: 300°C

ANSI300

DN	Sliding unit: carbon/SFC - stainless steel, coated								Sliding unit: STN2							
	max. admissible pressures for GS3-valves in stainless steel								max. admissible pressures for GS3-valves in stainless steel							
	38°C	50°C	100°C	150°C	200°C	250°C	300°C	350°C	38°C	50°C	100°C	150°C	200°C	250°C	300°C	350°C
15-65	49,6	48,1	42,2	38,5	35,7	33,4	31,6	30,3	49,6	48,1	42,2	38,5	35,7	33,4	31,6	30,3
80	48,0	48,0	42,2	38,5	35,7	33,4	31,6	30,3	36,6	36,6	36,6	34,8	33,0	26,8	22,0	19,0
100	33,0	33,0	33,0	33,0	33,0	33,0	31,6	30,3	33,0	33,0	33,0	31,7	30,1	24,4	20,1	17,3
125	23,0	23,0	23,0	23,0	23,0	23,0	23,0	23,0	22,0	22,0	22,0	21,0	19,9	16,1	13,2	11,5
150	16,0	16,0	16,0	16,0	16,0	16,0	16,0	16,0	16,0	16,0	16,0	15,4	14,6	11,8	9,7	8,4

Limitation for SFC-sliding discs: 300°C

ANSI600

DN	Sliding unit: carbon/SFC - stainless steel, coated								Sliding unit: STN2							
	max. admissible pressures for GS3-valves in stainless steel								max. admissible pressures for GS3-valves in stainless steel							
	38°C	50°C	100°C	150°C	200°C	250°C	300°C	350°C	38°C	50°C	100°C	150°C	200°C	250°C	300°C	350°C
15-20	99,3	96,2	84,4	77,0	71,3	66,8	63,2	60,7	99,3	96,2	84,4	77,0	71,3	66,8	63,2	60,7
25	88,0	88,0	84,4	77,0	70,1	63,7	57,3	54,2	88,0	88,0	84,4	77,0	70,1	63,7	57,3	54,2
32	99,3	96,2	84,4	77,0	71,3	66,8	63,2	60,7	99,3	96,2	84,4	77,0	71,3	66,8	63,2	60,2
40	88,0	88,0	84,4	77,0	70,1	63,7	57,3	54,2	72,5	72,5	72,5	69,0	65,5	53,1	43,6	37,7
50	99,3	96,2	84,4	77,0	71,3	66,8	63,2	60,7	77,7	77,7	77,7	73,9	70,2	56,9	46,7	40,4
65	80,0	80,0	80,0	77,0	71,3	66,8	63,2	60,7	62,5	62,5	41,7	59,5	56,4	45,8	37,6	32,5
80	48,0	48,0	48,0	48,0	48,0	48,0	48,0	44,5	36,6	36,6	36,6	34,8	33,0	26,8	22,0	19,0

Limitation for SFC-sliding discs: 300°C

Control Valve 8021-GS3



with integrated positioner

Application limitations for GS3 valves in carbon steel

These pressure must not be exceeded for GS-valves from the GS3-series made of carbon steel, even though the actuator power might allow it.

PN40

DN	Sliding unit: carbon/SFC - stainless steel, coated						Sliding unit: STN2					
	max. admissible pressures for GS3-valves in carbon steel						max. admissible pressures for GS3-valves in carbon steel					
	100°C	150°C	200°C	250°C	300°C	350°C	100°C	150°C	200°C	250°C	300°C	350°C
15-50	40	40	40	40	40	40	40	40	40	40	40	40
65	40	40	40	40	40	40	40	40	40	37	32	
80	40	40	40	40	40	40	36	34	33	26	22	19
100	33	33	33	33	33	33	33	31	30	24	20	17
125	23	23	23	23	23	23	22	21	19	16	13	11
150	16	16	16	16	16	16	16	15	14	11	9	8
200 (only PN 16)	16	16	15	13	12	11	-	-	-	-	-	-
250 (only PN 16)	10	9	9	8	7	6	-	-	-	-	-	-

Limitation for SFC-sliding discs: 300°C

PN100

DN	Sliding unit: carbon/SFC - stainless steel, coated						Sliding unit: STN2					
	max. admissible pressures for GS3-valves in carbon steel						max. admissible pressures for GS3-valves in carbon steel					
	100°C	150°C	200°C	250°C	300°C	350°C	100°C	150°C	200°C	250°C	300°C	350°C
15 - 20	100	100	100	100	100	100	100	100	100	100	100	100
25	100	100	100	100	100	94	87	100	100	100	94	87
32	100	100	100	100	100	100	99	100	100	84	69	60
40	100	100	100	100	100	94	87	72	69	65	53	43
50	100	100	100	100	100	100	94	77	73	70	56	46
65	80	80	80	80	80	80	76	62	59	56	45	37
80	48	48	48	48	48	48	44	36	34	33	26	22

Limitation for SFC-sliding discs: 300°C

ANSI150

DN	Sliding unit: carbon/SFC - stainless steel, coated								Sliding unit: STN2							
	max. admissible pressures for GS3-valves in carbon steel								max. admissible pressures for GS3-valves in carbon steel							
	38°C	50°C	100°C	150°C	200°C	250°C	300°C	350°C	38°C	50°C	100°C	150°C	200°C	250°C	300°C	350°C
15-125	19,6	19,2	17,7	15,8	13,8	12,1	10,2	8,4	19,6	19,2	17,7	15,8	13,8	12,1	10,2	8,4
150	16,0	16,0	16,0	15,8	13,8	12,1	10,2	8,4	16,2	16,2	16,2	15,4	13,8	11,8	9,7	8,0
200	16,0	16,0	16,0	15,8	13,8	12,1	10,2	8,4	-	-	-	-	-	-	-	-
250	10,5	10,5	10,5	9,9	9,4	8,4	7,4	6,0	-	-	-	-	-	-	-	-

Limitation for SFC-sliding discs: 300°C

ANSI300

DN	Sliding unit: carbon/SFC - stainless steel, coated								Sliding unit: STN2							
	max. admissible pressures for GS3-valves in carbon steel								max. admissible pressures for GS3-valves in carbon steel							
	38°C	50°C	100°C	150°C	200°C	250°C	300°C	350°C	38°C	50°C	100°C	150°C	200°C	250°C	300°C	350°C
15-50	51,1	50,1	46,6	45,1	43,8	41,9	39,8	37,6	51,1	50,1	46,6	45,1	43,8	41,9	39,8	37,6
65	51,1	50,1	46,6	45,1	43,8	41,9	39,8	37,6	41,7	41,7	41,7	39,7	37,6	33,5	37,6	33,0
80	48,0	48,0	46,6	45,1	43,8	41,9	39,8	37,6	36,6	36,6	36,6	34,8	33,0	26,8	22,0	19,0
100	33,0	33,0	33,0	33,0	33,0	33,0	33,0	33,0	33,0	33,0	33,0	31,7	30,1	24,4	20,0	17,5
125	23,0	23,0	23,0	23,0	23,0	23,0	23,0	23,0	22,1	22,1	22,1	21,0	19,9	16,1	13,2	11,5
150	16,0	16,0	16,0	16,0	16,0	16,0	16,0	16,0	16,0	16,0	16,0	15,4	14,6	11,8	9,7	8,4

Limitation for SFC-sliding discs: 300°C

Control Valve 8021-GS3

with integrated positioner Type 8049

Dimensions and Weights

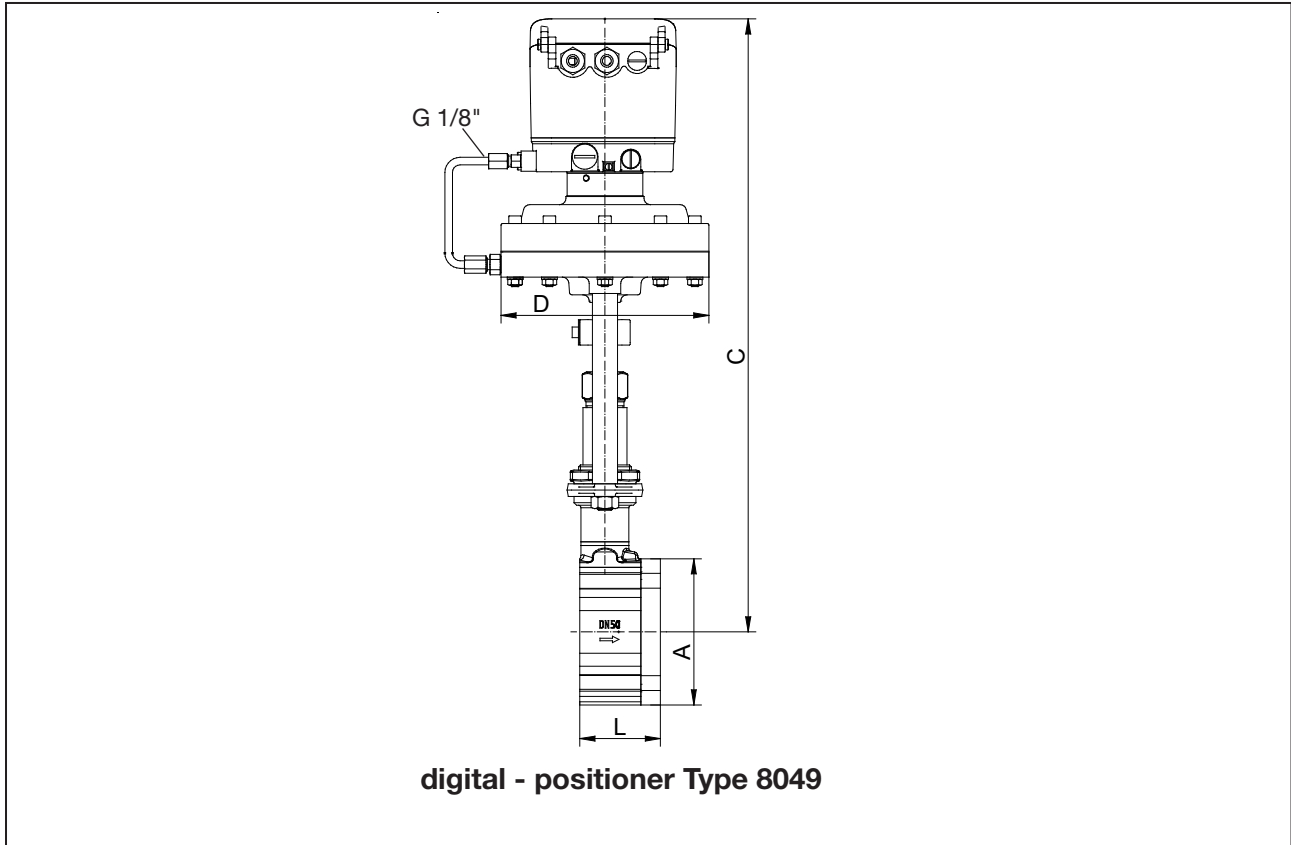

DN	Ø A	C*	Ø D for actuator			L	Stroke	Weight (kg) for actuator		
			D 125	D250	D 500			D 125	D 250	D500
15	64	460	165	222	222	56	6	7,5	9,7	13,4
20	72	465	165	222	222	56	6	7,7	9,9	13,6
25	82	470	165	222	222	56	6	8,1	10,3	14,0
32	89	475	165	222	222	56	6	8,5	10,7	14,4
40	99	480	165	222	222	56	6	8,9	11,1	14,8
50	116	490	165	222	222	64	8	10,5	12,7	16,4
65	138	500	165	222	222	68	8	12,3	14,5	18,2
80	153	510	165	222	222	70	8	13,4	15,6	19,3
100	184	520	165	222	222	75	8,5	16,9	19,1	22,8
125	212	535	165	222	222	80	8,5	21,1	23,3	27,0
150	242	550	165	222	222	80	8,5	24,8	27,0	30,7
200	302	580	165	222	222	93	8,5	41,7	43,9	47,6
250	360	605	165	222	222	96	8,5	46,9	49,1	52,8

* for actuator D500 +47,5mm

Dimensions in mm

Control Valve 8021-GS3

with integrated i/p and p/p-positioner Type 8047

Dimensions and Weights

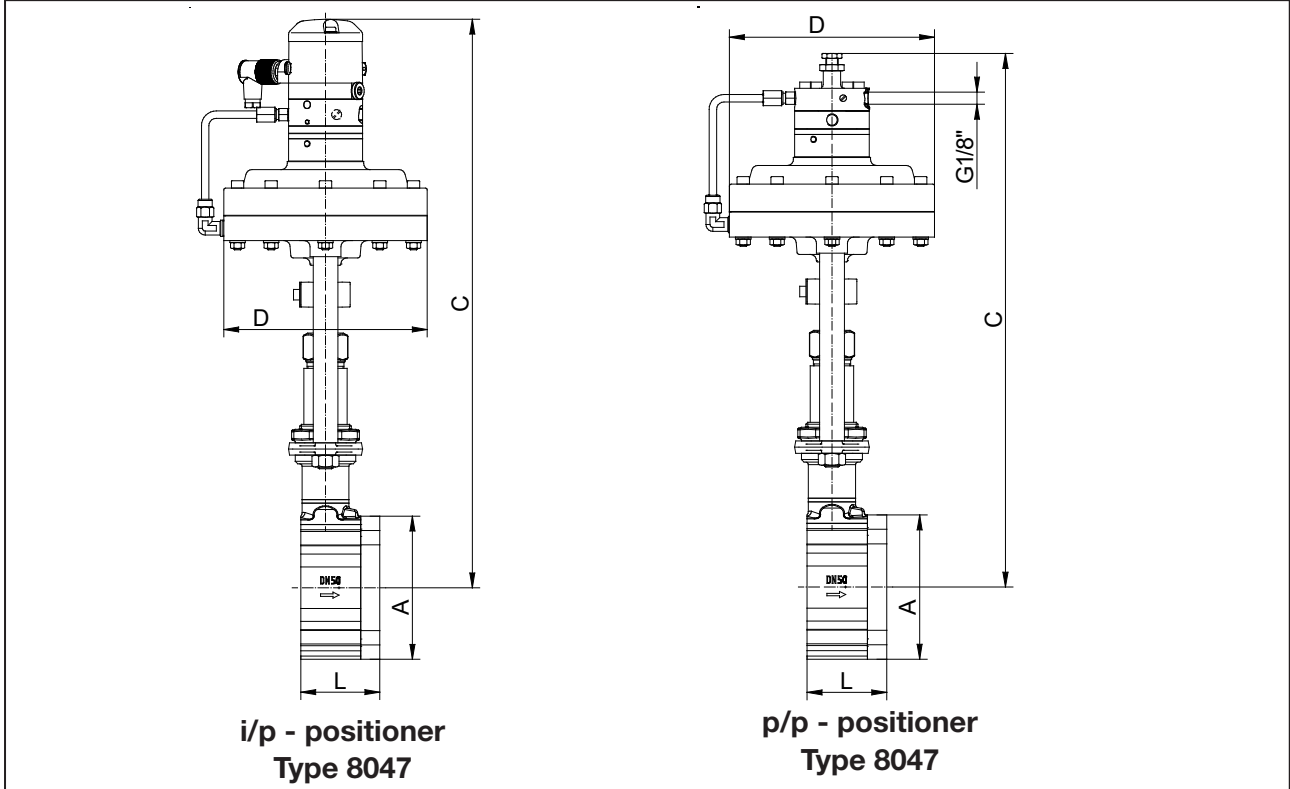

DN	Ø A	C1*	C2*	Ø D for actuator			L	Stroke	Weight (kg) for actuator		
				D 125	D250	D 500			D 125	D 250	D500
15	64	430	400	165	222	222	56	6	7,5	9,7	13,4
20	72	435	405	165	222	222	56	6	7,7	9,9	13,6
25	82	440	410	165	222	222	56	6	8,1	10,3	14,0
32	89	445	415	165	222	222	56	6	8,5	10,7	14,4
40	99	450	420	165	222	222	56	6	8,9	11,1	14,8
50	116	460	430	165	222	222	64	8	10,5	12,7	16,4
65	138	470	440	165	222	222	68	8	12,3	14,5	18,2
80	153	480	450	165	222	222	70	8	13,4	15,6	19,3
100	184	490	460	165	222	222	75	8,5	16,9	19,1	22,8
125	212	505	475	165	222	222	80	8,5	21,1	23,3	27,0
150	242	520	490	165	222	222	80	8,5	24,8	27,0	30,7
200	302	550	520	165	222	222	93	8,5	41,7	43,9	47,6
250	360	575	545	165	222	222	96	8,9	46,9	49,9	52,8

* for actuator D500 +47,5mm

Dimensions in mm

Control Valve 8021-GS3

Special version with D750 actuator

Standard with stainless steel coupling and valve stem made of material 1.4122.

Admissible differential pressures

(For temperatures of up to 120°C with PN-rating
up to 38°C with ANSI-rating)

**For temperatures of 120°C (PN) or
38°C (ANSI) and above:
obey application limits!**

Sealing disc pairing	Carbon material - stainless steel coated SFC - stainless steel coated Carbon material - Alloy C-276			STN 2 / STN 3		
	1,5	3,5	4	1,5	4	4,5
Supply air pressure (bar)						
DN	Max. permissible differential pressure in bar					
100	20	33	33	7,7	30	33
125	13,5	23	23	5,1	20	23
150	10	16	16	3,8	14,5	16
200	5,9	16	16	2,1	8,5	10
250	3,6	12	12	1,3	5,2	6,2
Spring assembly	Code L	Standard	Code P	Code L	Standard	Code P

Standard

Upper limits of the pressure rating

	Upper limits for admissible pressures in bar					
	PN16	PN40	PN100	ANSI150	ANSI 300	ANSI 600
P max. carbon steel/ Alloy C-276	16	40	100	19,6	51,1	102,1
P max. stainless steel				19,0	49,6	99,3

Dimensions and Weights

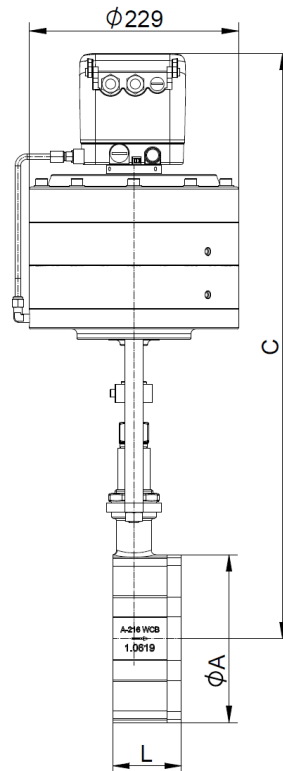

DN	Ø A	C	L	Stroke	Weight (kg)
100	184	641	75	8,5	25,8
125	212	656	80	8,5	30,0
150	242	671	80	8,5	33,7
200	302	701	93	8,5	50,6
250	360	726	96	8,5	55,8

Dimensions in mm