

PF75S

Electromagnetic flow meter for industrial applications

PF75S-5#####03#####A#00#0

Overview

- Volume and velocity measurements in one sensor
- Precise and stable measurements with accuracies to 0.2%
- For media with conductivity > 5 µS/cm in closed systems
- Measurement range 0 ... 4500 m³/h with pipe diameter DN 3 ... 400
- Robust and resistant to temperature jumps
- No energy loss thanks to continuous measuring tube without constriction
- Graphic display CombiView DFON optionally available and programmable via touch screen or BCP software



Technical data

Performance characteristics

Measuring principle	Electromagnetic flow measurement
Nominal diameter range	DN 3 ... DN 400
Hysteresis	3 % o. r.
Max. flow velocity	10 m/s
Max. measuring error	± 1.0 % o. r. ± 0.5 % o. r. , optional ± 0.2 % o. r. , optional
Max. turndown ratio	1 : 1000
Measuring range, flow	0 ... 10 m/s 0 ... 4500 m³/h
Media characteristics	≥ 5 µS/cm
Step response time	≤ 400 ms
Sampling interval	≤ 200 ms
Min. measuring span	0 ... 0.01 m³/h
Damping	0.2 ... 1000 s
Repeatability	≤ 0.1 % o. r.

Process conditions

Process temperature	According to the configuration
Process pressure	According to the configuration

Process connection

Connection variants	EN 1092-1 ASME (ANSI) B 16.5 / EN 1759-1 Class 150 DIN 228-1 male thread NPT male thread
Sensor tube dimensions	According to the configuration DN 3 ... DN 400 3 ... 400 mm
Sensor tube material	Painted steel AISI 316L (1.4404) AISI 304 (1.4301)
Wetted parts material, process connection	AISI 316L (1.4404) AISI 304 (1.4301)
Wetted parts material, liner	According to the configuration
Wetted parts material, electrodes	According to the configuration

Process connection

Wetted parts material, gas- ket	According to the configuration
------------------------------------	--------------------------------

Surface roughness (in contact with medium)

Process connection	Ra ≤ 0.8 µm
--------------------	-------------

Ambient conditions

Operating temperature	-20 ... 80 °C , with DFON touch screen -20 ... 85 °C , without DFON touch screen
Storage temperature range	-20 ... 60 °C
Altitude	-200 ... 4000 m
Degree of protection (EN 60529)	IP 65 IP 67
Humidity	0 ... 100 %
Insulation resistance	> 100 MΩ
Insulation voltage	500 V DC

Output signal

Digital output signal	1 x pulse / frequency / alarm 2 x pulse / frequency / alarm (optional)
Analog output (optional)	0...20 mA 4...20 mA
Voltage drop	1.2 V DC
Relays	2 relays included in the display
Load resistance	≤ 200 Ω, Vs = 10 V DC ≤ 1000 Ω, Vs = 30 V DC
Short circuit protection	No
Damping	0.2 ... 1000 s

Housing

Style	FlexHousing, Ø80 mm Bottom process connection
Overall size	Refer to section "Dimensional drawings"
Material	AISI 304 (1.4301)

Electrical connection

Cable gland	M16x1.5, plastic M16x1.5, stainless steel M20x1.5, plastic M20x1.5, stainless steel
-------------	--

PF75S

Electromagnetic flow meter for industrial applications

PF75S-5#####03#####A#00#0

Technical data

Power supply

Voltage supply range	18 ... 30 V DC
Power consumption	≤ 5 W
Power-up time	≤ 30 s , standard use ≤ 15 min , warm-up for calibration

Power supply

Reverse polarity protection	Yes
-----------------------------	-----

Compliance and approvals

EMC	IEC 61326-1 EN 61326-1
-----	---------------------------

Operating conditions

Nominal diameter	Min. measuring span		Max. measuring span	
DN3	0 ... 0.01 m ³ /h	0 ... 2.6 gal/h	0 ... 0.25 m ³ /h	0 ... 66 gal/h
DN6	0 ... 0.04 m ³ /h	0 ... 10.6 gal/h	0 ... 1.0 m ³ /h	0 ... 264 gal/h
DN10	0 ... 0.11 m ³ /h	0 ... 29.1 gal/h	0 ... 2.8 m ³ /h	0 ... 740 gal/h
DN15	0 ... 0.25 m ³ /h	0 ... 66.0 gal/h	0 ... 6 m ³ /h	0 ... 1585 gal/h
DN20	0 ... 0.45 m ³ /h	0 ... 118.9 gal/h	0 ... 11 m ³ /h	0 ... 2906 gal/h
DN25	0 ... 0.72 m ³ /h	0 ... 190.2 gal/h	0 ... 18 m ³ /h	0 ... 4755 gal/h
DN32	0 ... 1.16 m ³ /h	0 ... 306.4 gal/h	0 ... 29 m ³ /h	0 ... 7660 gal/h
DN40	0 ... 1.8 m ³ /h	0 ... 475.5 gal/h	0 ... 45 m ³ /h	0 ... 11887 gal/h
DN50	0 ... 2.88 m ³ /h	0 ... 760.8 gal/h	0 ... 72 m ³ /h	0 ... 19020 gal/h
DN65	0 ... 4.8 m ³ /h	0 ... 1268.0 gal/h	0 ... 120 m ³ /h	0 ... 31700 gal/h
DN80	0 ... 7.2 m ³ /h	0 ... 1902.0 gal/h	0 ... 180 m ³ /h	0 ... 47550 gal/h
DN100	0 ... 11.2 m ³ /h	0 ... 2958.7 gal/h	0 ... 280 m ³ /h	0 ... 73968 gal/h
DN125	0 ... 18.0 m ³ /h	0 ... 4755.0 gal/h	0 ... 450 m ³ /h	0 ... 118877 gal/h
DN150	0 ... 25.6 m ³ /h	0 ... 6762.8 gal/h	0 ... 640 m ³ /h	0 ... 169070 gal/h
DN200	0 ... 45.2 m ³ /h	0 ... 11940.6 gal/h	0 ... 1130 m ³ /h	0 ... 298514 gal/h
DN250	0 ... 70.8 m ³ /h	0 ... 18703.4 gal/h	0 ... 1770 m ³ /h	0 ... 467584 gal/h
DN300	0 ... 100.8 m ³ /h	0 ... 26628.5 gal/h	0 ... 2520 m ³ /h	0 ... 665714 gal/h
DN350	0 ... 138.0 m ³ /h	0 ... 36455.7 gal/h	0 ... 3450 m ³ /h	0 ... 911394 gal/h
DN400	0 ... 180.0 m ³ /h	0 ... 47551.0 gal/h	0 ... 4500 m ³ /h	0 ... 1188774 gal/h

Note: gal is defined as US liq. gal.

Display

General information

Panel type	FSTN Graphical LCD
Display range	-9999 ... 99999
Max. digit height	22 mm
Material	Polycarbonate

Ambient conditions

Operating temperature range	-20 ... 80 °C
Optimal readability temperature range	-10 ... 70 °C

Input signal

Update time	≤ 1 s , max. 0.3 s , typ.
-------------	------------------------------

User configurable data

Error- / Warning-indication	Individually configurable display and backlight indication in white, green or red colour, steady or flashing light. Configurable limits over the range
-----------------------------	--

Measuring unit	μS/cm mS/cm % °C °F cm/s Hz kHz l/h m/s m ³ /h
----------------	---

User defined measuring unit	8 × 20 pixel matrix
-----------------------------	---------------------

Relays

Contacts	2 x solid state relays
Max. load current	75 mA
Max. switching voltage	60 V

PF75S

Electromagnetic flow meter for industrial applications

PF75S-5#####03#####A#00#0

Dimensional drawings (mm)

Nominal diameter	Process connection	Nominal pressure	D	H	L
DN3	EN 1092-1	PN16	90.0 mm	142.0 mm	200.0 mm
DN6	EN 1092-1	PN16	90.0 mm	142.0 mm	200.0 mm
DN10	EN 1092-1	PN16	90.0 mm	142.0 mm	200.0 mm
DN15	EN 1092-1	PN16	95.0 mm	144.5 mm	200.0 mm
DN20	EN 1092-1	PN16	105.0 mm	149.5 mm	200.0 mm
DN25	EN 1092-1	PN16	115.0 mm	195.0 mm	200.0 mm
DN32	EN 1092-1	PN16	140.0 mm	201.0 mm	200.0 mm
DN40	EN 1092-1	PN16	150.0 mm	211.0 mm	200.0 mm
DN50	EN 1092-1	PN16	165.0 mm	225.0 mm	200.0 mm
DN65	EN 1092-1	PN16	185.0 mm	245.0 mm	200.0 mm
DN80	EN 1092-1	PN16	200.0 mm	255.0 mm	200.0 mm
DN100	EN 1092-1	PN16	220.0 mm	281.0 mm	250.0 mm
DN125	EN 1092-1	PN16	250.0 mm	281.0 mm	250.0 mm
DN150	EN 1092-1	PN16	285.0 mm	335.0 mm	300.0 mm
DN200	EN 1092-1	PN16	340.0 mm	393.0 mm	350.0 mm
DN250	EN 1092-1	PN16	405.0 mm	451.0 mm	450.0 mm
DN300	EN 1092-1	PN16	460.0 mm	547.0 mm	502.0 mm
DN350	EN 1092-1	PN16	520.0 mm	577.0 mm	552.0 mm
DN400	EN 1092-1	PN16	580.0 mm	607.0 mm	602.0 mm
DN25	EN 1092-1	PN25	115.0 mm	195.0 mm	200.0 mm
DN32	EN 1092-1	PN25	140.0 mm	201.0 mm	200.0 mm
DN40	EN 1092-1	PN25	150.0 mm	211.0 mm	200.0 mm
DN50	EN 1092-1	PN25	165.0 mm	225.0 mm	200.0 mm
DN65	EN 1092-1	PN25	185.0 mm	245.0 mm	200.0 mm
DN80	EN 1092-1	PN25	200.0 mm	255.0 mm	200.0 mm
DN100	EN 1092-1	PN25	235.0 mm	281.0 mm	250.0 mm
DN125	EN 1092-1	PN25	270.0 mm	281.0 mm	250.0 mm
DN150	EN 1092-1	PN25	300.0 mm	335.0 mm	300.0 mm
DN200	EN 1092-1	PN25	360.0 mm	393.0 mm	350.0 mm
DN250	EN 1092-1	PN25	425.0 mm	451.0 mm	450.0 mm
DN25	EN 1092-1	PN40	115.0 mm	195.0 mm	200.0 mm
DN32	EN 1092-1	PN40	140.0 mm	201.0 mm	200.0 mm
DN40	EN 1092-1	PN40	150.0 mm	211.0 mm	200.0 mm
DN50	EN 1092-1	PN40	165.0 mm	225.0 mm	200.0 mm
DN65	EN 1092-1	PN40	185.0 mm	245.0 mm	200.0 mm
DN80	EN 1092-1	PN40	200.0 mm	255.0 mm	200.0 mm
DN100	EN 1092-1	PN40	235.0 mm	281.0 mm	250.0 mm
DN125	EN 1092-1	PN40	270.0 mm	281.0 mm	250.0 mm
DN150	EN 1092-1	PN40	300.0 mm	335.0 mm	300.0 mm
DN200	EN 1092-1	PN40	375.0 mm	393.0 mm	350.0 mm
DN250	EN 1092-1	PN40	450.0 mm	451.0 mm	450.0 mm
DN200	EN 1092-1	PN40	375.0 mm	393.0 mm	350.0 mm
DN250	EN 1092-1	PN40	450.0 mm	451.0 mm	450.0 mm

Attention: Nominal diameters DN3 and DN6 have process connections of size DN10

PF75S

Electromagnetic flow meter for industrial applications

PF75S-5#####03#####A#00#0

Dimensional drawings (mm)

Nominal diameter	Process connection	Nominal pressure	D	H	L
DN3	ASME B 16.5 Class 150	PN16	88.9 mm	141.5 mm	200.0 mm
DN6	ASME B 16.5 Class 150	PN16	88.9 mm	141.5 mm	200.0 mm
DN10	ASME B 16.5 Class 150	PN16	88.9 mm	141.5 mm	200.0 mm
DN15	ASME B 16.5 Class 150	PN16	88.9 mm	141.5 mm	200.0 mm
DN20	ASME B 16.5 Class 150	PN16	98.4 mm	146.2 mm	200.0 mm
DN25	ASME B 16.5 Class 150	PN16	108.0 mm	195.0 mm	200.0 mm
DN32	ASME B 16.5 Class 150	PN16	117.3 mm	201.0 mm	200.0 mm
DN40	ASME B 16.5 Class 150	PN16	127.0 mm	211.0 mm	200.0 mm
DN50	ASME B 16.5 Class 150	PN16	152.4 mm	225.0 mm	200.0 mm
DN65	ASME B 16.5 Class 150	PN16	177.8 mm	245.0 mm	200.0 mm
DN80	ASME B 16.5 Class 150	PN16	190.5 mm	255.0 mm	200.0 mm
DN100	ASME B 16.5 Class 150	PN16	228.6 mm	281.0 mm	250.0 mm
DN125	ASME B 16.5 Class 150	PN16	254.0 mm	281.0 mm	250.0 mm
DN150	ASME B 16.5 Class 150	PN16	279.4 mm	335.0 mm	300.0 mm
DN200	ASME B 16.5 Class 150	PN16	342.9 mm	393.0 mm	350.0 mm
DN250	ASME B 16.5 Class 150	PN16	406.4 mm	451.0 mm	450.0 mm
DN300	ASME B 16.5 Class 150	PN16	482.6 mm	489.0 mm	500.0 mm
DN350	ASME B 16.5 Class 150	PN16	508.0 mm	502.0 mm	550.0 mm
DN400	ASME B 16.5 Class 150	PN16	584.5 mm	540.0 mm	600.0 mm

Attention: Nominal diameters DN3, DN6 and DN10 have process connections of size DN15

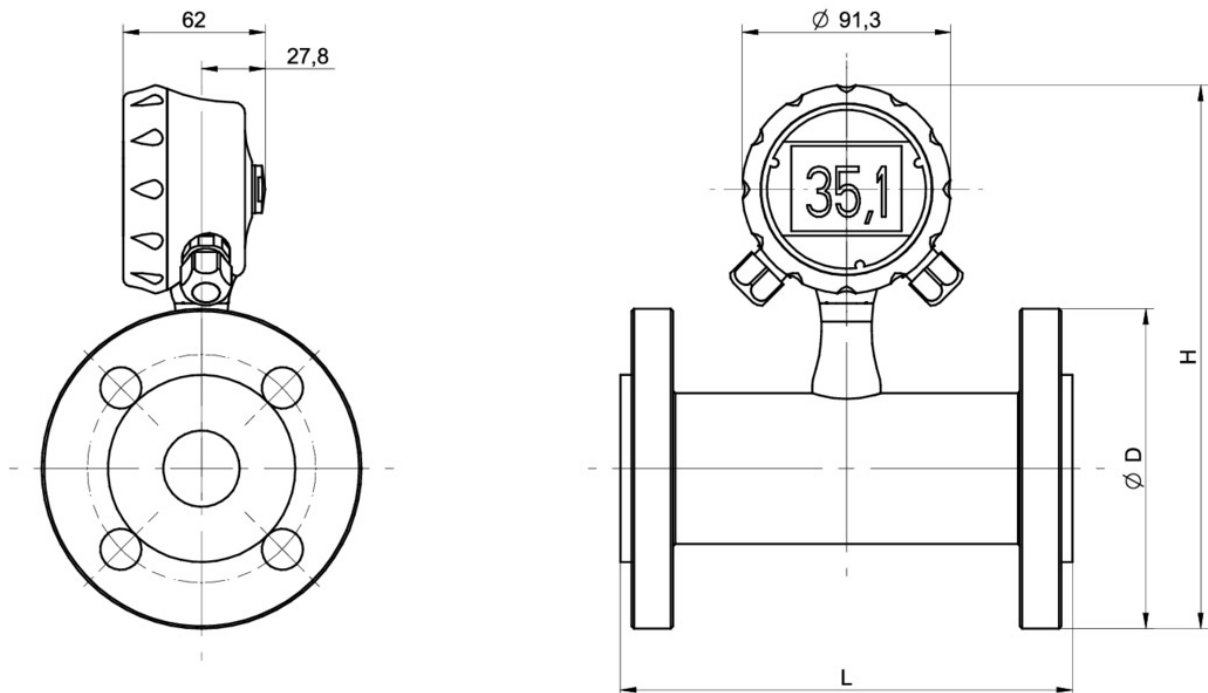

Nominal diameter	Process connection	Nominal pressure	D	H	L
DN3	1/2" DIN 228-1 male thread	PN16	76.0 mm	211.0 mm	200.0 mm
DN6	1/2" DIN 228-1 male thread	PN16	76.0 mm	211.0 mm	200.0 mm
DN10	3/4" DIN 228-1 male thread	PN16	76.0 mm	211.0 mm	200.0 mm
DN15	1" DIN 228-1 male thread	PN16	76.0 mm	211.0 mm	200.0 mm
DN20	1 1/4" DIN 228-1 male thread	PN16	76.0 mm	211.0 mm	200.0 mm

PF75S

Electromagnetic flow meter for industrial applications

PF75S-5#####03#####A#00#0

Dimensional drawings (mm)

Nominal diameter	Process connection	Nominal pressure	D	H	L
DN3	1/2" NPT male thread	PN16	76.0 mm	211.0 mm	128.0 mm
DN6	1/2" NPT male thread	PN16	76.0 mm	211.0 mm	128.0 mm
DN10	3/4" NPT male thread	PN16	76.0 mm	211.0 mm	128.0 mm
DN15	1" NPT male thread	PN16	76.0 mm	211.0 mm	128.0 mm
DN20	1 1/4" NPT male thread	PN16	76.0 mm	211.0 mm	128.0 mm

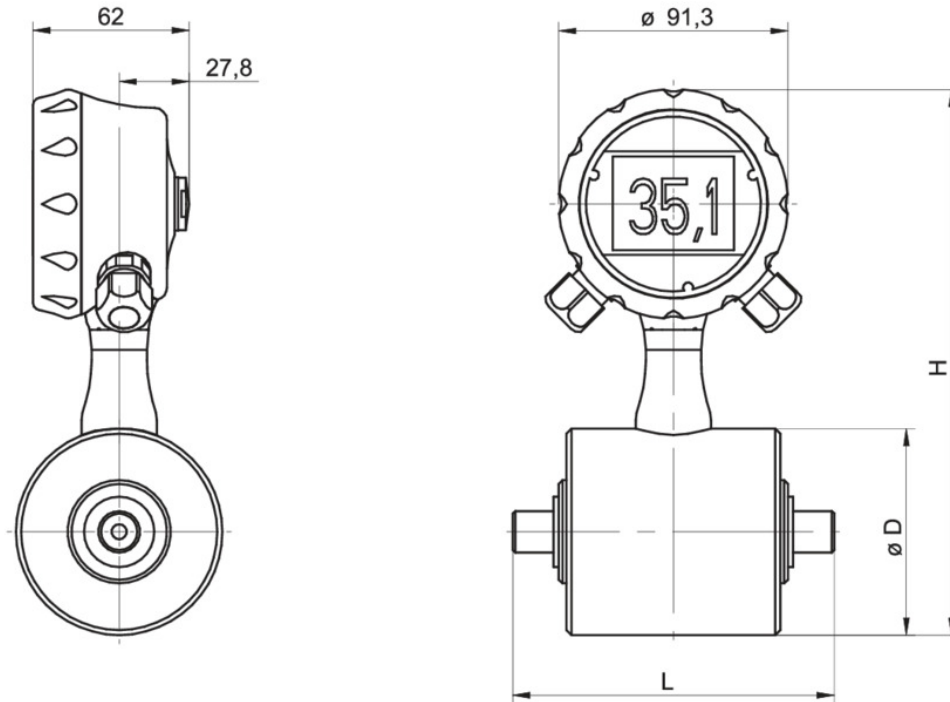

PF75S

Electromagnetic flow meter for industrial applications

PF75S-5#####03#####A#00#0

Electrical connection

M12-A, 5-pin

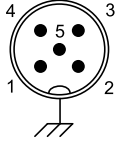

M12-A, 8-pin

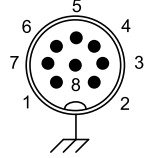

Left side connection (front view): M12-A, 5-pin

Function			Pin assignment
Vs +	Power supply +	10 ... 30 V DC	1
Vs -	Power supply -	10 ... 30 V DC	3
Iout +	Flowrate	4 ... 20 mA	2
Iout -	Flowrate	4 ... 20 mA	4
GND	Earth		5

Right side connection (front view): M12-A, 8-pin

Function (with display)			Pin assignment
Out 1 +	Digital output 1	Selectable	1
Out 2 +	Digital output 2	Selectable	8
In +	Digital input	Selectable	2
I/O -	Input/output common -	Selectable	7
R11	Relay 1		5
R12	Relay 1		6
R21	Relay 2		3
R22	Relay 2		4

Function (without display)			Pin assignment
Out 1 +	Digital output 1	Selectable	1
Out 2 +	Digital output 2	Selectable	8
In +	Digital input	Selectable	2
I/O -	Input/output common -	Selectable	7
		n.c.	5
		n.c.	6
		n.c.	3
		n.c.	4

PF75S

Electromagnetic flow meter for industrial applications

PF75S-5#####03#####A#00#0

Electrical connection

Terminal assignment transmitter

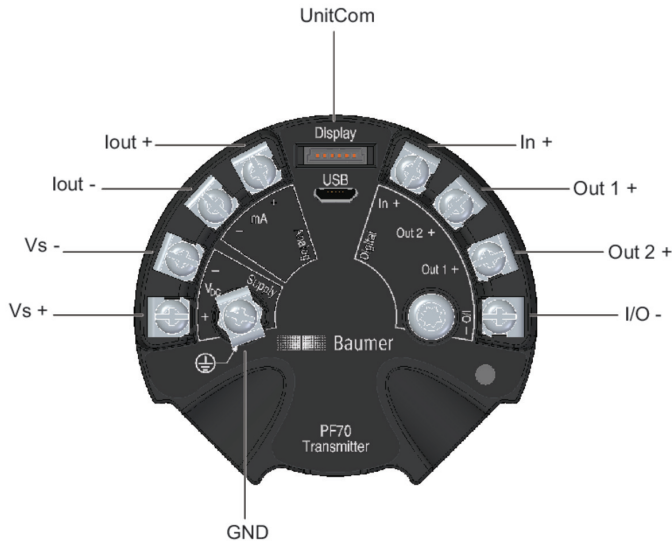

Terminal assignment DFON display



PF75S

Electromagnetic flow meter for industrial applications

PF75S-5#####03#####A#00#0

Ordering information

Ordering key - Configuration possibilities see website

	PF75S	-	5	#	#	#	#	#	#	#	0	3	#	#	#	#	#	#	#	A	#	0	0	#	0
Product	PF75S																								
Housing																									
Stainless steel 1.4301 / AISI304			5																						
Bottom connection																									
Max. measurement error																									
±1.0 % o.r																									
±0.5 % o.r																									
±0.2 % o.r																									
Display																									
Without display																									
With display, with activated relays																									
Output signal analog																									
Without																									
4 ... 20 mA																									
Output signal digital																									
Without Pulse / frequency output																									
1 x Pulse / frequency output (programmable)																									
2 x Pulse / frequency output (programmable)																									
Interface																									
Without																									
HART®																									
Electrical connection																									
1 x M12-A, 5-pin																									
2 x M16x1.5 cable gland																									
2 x M20x1.5 cable gland																									
1 x M12-A, 5-pin + 1 x M12-A, 8-pin																									
Material of el. connection																									
Plastic																									
Stainless steel, AISI 304 (1.4301)																									
Cable length																									
Without																									
Protection class																									
IP65, IP67																									
Process temperature (conti.)																									
0 ... 60 °C																									
0 ... 70 °C																									
-5 ... 80 °C																									
-20 ... 100 °C																									
Max. process pressure																									
PN16																									
PN25																									
PN40																									

PF75S

Electromagnetic flow meter for industrial applications

PF75S-5#####03#####A#00#0

Ordering information

Ordering key - Configuration possibilities see website

PF75S - 5 # # # # # # # 0 3 # # # # # # # # A # 0 0 # 0

Nominal diameter

DN3	A
DN6	B
DN10	C
DN15	D
DN20	E
DN25	F
DN32	G
DN40	H
DN50	I
DN65	J
DN80	K
DN100	L
DN125	M
DN150	N
DN200	O
DN250	P
DN300	Q
DN350	R
DN400	S

Process connection

DIN 228-1 male thread	1
NPT male thread	2
EN 1092-1	A
ASME B 16.5 Class 150	B

Sensor body and process connec

Painted steel	1
AISI 316L	2
AISI 304	3

Liner material

PTFE	1
PP	3
Ebonite	4
Rilsan	5
Abral	6

Electrodes material

AISI 316L	1
Hastelloy C	2
Titanium	4
Tantalum	5

Number of electrodes

Two electrodes	2
Three electrodes	3
Four electrodes	4

Surface finish

Ra ≤ 0,8 µm	A
-------------	---

PF75S

Electromagnetic flow meter for industrial applications

PF75S-5#####03#####A#00#0

Ordering information

Ordering key - Configuration possibilities see website

	PF75S	-	5	#	#	#	#	#	#	#	0	3	#	#	#	#	#	#	A	#	0	0	#	0		
Sealing-/ O-ring material (int)																										
FKM																									1	
FFKM																										3
EPDM																										4
Sealing by lining																										7
Special approvals																										
Standard																										0
Measuring Instr. Directive																										
Without																										0
Calibration certificate																										
2 point calibration certificat (standard)																										0
3 point calibration certificat																										1
5 point calibration certificat																										2
10 point calibration certificate																										3
Configuration / Parametrizatio																										
Factory settings																										0

2022-05-03 The product features and technical data specified do not express or imply any warranty. Technical modifications subject to change.