

Data sheet | Technical Description and Installation Instructions

Document number: DB-KU-100237-3

From firmware version: V2.00.00

Initial creation: Juni 2021

From serial number: xxx1044



DML02 | DML02_ex version:

Viscosity sensor VLO-M2 | VLO-M2_ex



Contents

Notes about the data sheet	3
Safety notes	3
Product description	4
Installation, start-up and uninstallation	5
Cleaning and repair	8
Disposal	8
Product specification	9
Modbus	13
Download area	18
Website	19



Notes about the data sheet

Use and safekeeping

- This data sheet is an integral component of the viscosity sensor.
- Keep the data sheet in the immediate vicinity of the place of use.
- In case of transfer to third parties, pass on data sheet or relevant content to them.
- Read the data sheet carefully.
- We reserve the right to make changes.

⚠ WARNING

Use of the VLO-M2_ex version

This document is only valid in connection with the VLO-M2_ex with the safety instructions DB-KU-100206-*. The asterisk (*) stands for the version.

Function

The data sheet provides information for safe use and installation of the viscosity sensor.

Symbols used

The following symbols are used in the data sheet to draw attention to dangerous situations and to indicate instructions for action:

Symbol	Description
⚠ WARNING	Leads to death or serious injury if not avoided.
NOTICE	Information on facts that do not involve physical injury.
▶	Single-step handling instruction
1. / 2. / 3.	Multi-step handling instruction

Safety notes

Intended use

- Depending on the ordered version, the measuring instrument can also measure explosive and inflammable media.
- Measuring instruments for use in hazardous areas are specially marked on the type plate.
- The viscosity sensor is to be used exclusively for measuring the density of fluids. Only permitted media may be used.
- Check by means of the type plate whether the ordered measuring instrument can be used for its intended purpose in the area relevant for approval (e.g. explosion protection).
- Failure to observe the area of application can impair safety. The manufacturer shall not be held liable for damage arising from improper use.

Qualification of personnel

- The viscosity sensor may be installed by specialist personnel only.

Operating safety

- The owner/operator is responsible for interference-free operation of the viscosity sensor.
- Only operate the viscosity sensor in a technically perfect and safe operating condition.
- In case of increased medium temperature, ensure protection against accidental contact to avoid burns.
- Unauthorized modifications or repairs to the viscosity sensor are not permitted and can lead to unforeseeable dangers.

Product safety

- The viscosity sensor complies with the guidelines listed in the EU Declaration of Conformity. By affixing the CE mark, TrueDyne Sensors AG confirms this fact.



Product description

Overview

The viscosity sensor was designed for measuring the viscosity and density of fluids. This takes place using a microelectromechanical system (MEMS) with a microchannel shaped like the Greek letter omega (omega chip), which is built into an internal bypass.

When the medium flows through the viscosity sensor, the bypass arrangement generates a pressure gradient via the microchannel, which allows the medium to reach the omega chip. The medium influences the physical properties of the excited sensor (resonance frequency and quality), and these are digitized and evaluated in the microcontroller. The measured values can be read out via the serial interface (RS-485, Modbus).

Density measurements in the range 600 to 1000 kg/m³ (further options see product specifications) can be realized at a flow rate of 0 to 10 l/h.

Omega chip

The omega chip, a vibronic microsystem, is the heart of the measuring system and is used for sensor signal generation in the overall system. An essential component of this microsystem is a silicon tube (microchannel), which is electrostatically set into oscillation in a vacuum atmosphere. To compensate for temperature

effects, a platinum resistor is integrated, which allows local real-time temperature measurement. The omega chip essentially consists of crystalline silicon and glass.

Density measurement

The viscosity sensor uses the omega chip for density measurement. For this purpose, the filled microchannel is brought to resonant oscillation and analyzed.

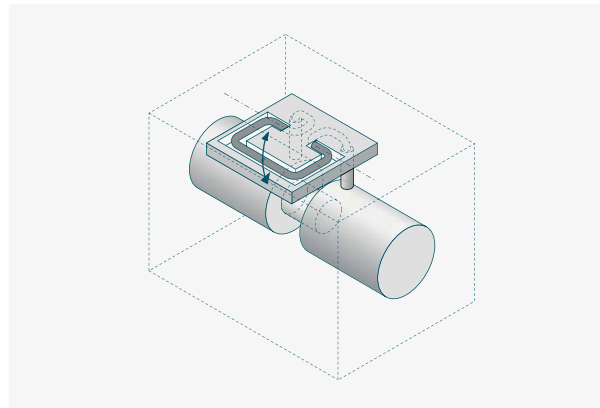

Measuring principle (omega chip)

The resulting natural frequency of the microchannel depends on the mass and thus on the density of the medium in the microchannel: The greater the density of the medium, the lower the natural frequency. Thus the natural frequency is a function of the medium density.

$$f \propto \sqrt{\frac{E \cdot I}{\rho_{\text{Tube}} \cdot A_{\text{Tube}} + \rho_{\text{Fluid}} \cdot A_{\text{Fluid}}}}$$

f = natural frequency, E · I = stiffness of the tube, ρ_{Tube} = tube density, A_{Tube} = tube cross-section, ρ_{Fluid} = medium density, A_{Fluid} = medium cross-section

Possible applications

The viscosity sensor can be used for direct and indirect density measurements. While a product property or quality can be determined with the direct density measurement, an indirect density measurement using tables and calculation algorithms makes it possible to determine the concentration of liquid mixtures.

The viscosity sensor can be used in the following applications, for example:

- Addition of volumetric flow measurement in orifices, turbines or displacement devices to enable mass measurement. The viscosity sensor takes temperature changes and (if an additional pressure sensor is connected) pressure changes into account.
- Monitoring and controlling the quality of fuel mixtures such as E10 or biodiesel.



Product design

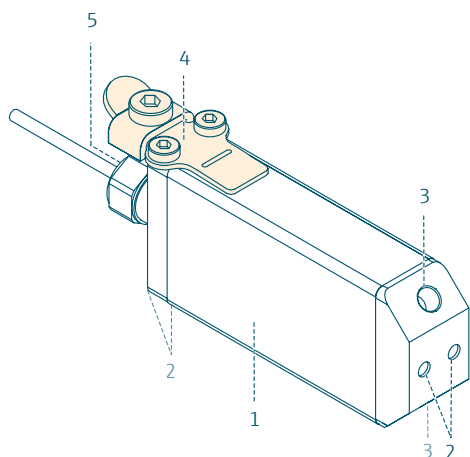

Product design of viscosity sensor VLO-M2 | VLO-M2_ex

- 1 Viscosity sensor VLO-M2(_ex)
- 2 Mounting holes for mechanical fastening (6 x M3 threaded holes)
- 3 Fluid interface (2 x M5 threaded holes)
- 4 Clamp on grounding plate with screws M3x8 TORX
- 5 Electronic interface for communication and power supply

NOTICE

For the VLO-M2 (non-ex), item 4 (clamp on grounding plate with screws M3x8 TORX) is not applicable. Marked orange in the graphic.

Scope of delivery

- Viscosity sensor (including transport safety devices)

Product identification

The viscosity sensor is identified by a consecutive, eleven-digit serial number. This is installed on the outside of the housing and can also be viewed via Modbus.

Installation, start-up and uninstallation

Fastening the viscosity sensor mechanically

- ▶ Fix the viscosity sensor with M3 screws using the provided mounting holes (4 mm depth). Maximal tightening torque 30 cNm (typically 15 to 20 cNm)

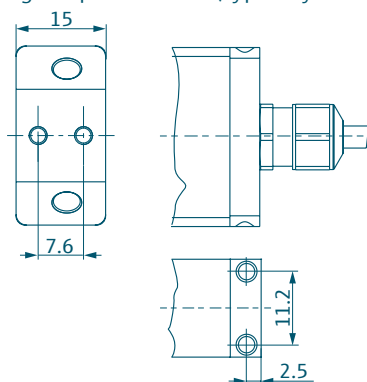

Dimensions in mm for mechanical fastening

Making the fluid connections for the viscosity sensor

- With a flow rate >10 l/h, installation in a bypass line is recommended to limit the flow rate through the viscosity sensor to <10 l/h.
- The bypass line can be led to a collecting tank or back to the main line.

⚠ WARNING

Danger of injury due to dangerous process conditions and pipe break

- ▶ Empty and depressurize the pipeline before installing the viscosity sensor.
- ▶ Take high temperatures into account.
- ▶ If necessary, fasten the viscosity sensor mechanically.

NOTICE

Clogging of the microchannel

- ▶ If necessary, install a filter upstream of the viscosity sensor to prevent the microchannel from clogging.

NOTICE

Delayed measurement signal for installation in bypass

- ▶ Note the time delay, for example for open-loop process control.

1. Remove all remaining packaging materials.
2. Remove transportation safety devices on fluid connections.



3. Install the viscosity sensor at fluid connections with M5 connectors (thread depth 5 mm) in the pipeline, whereby flow and installation direction are not relevant. Also follow the instructions in the operating manual of the connector used.

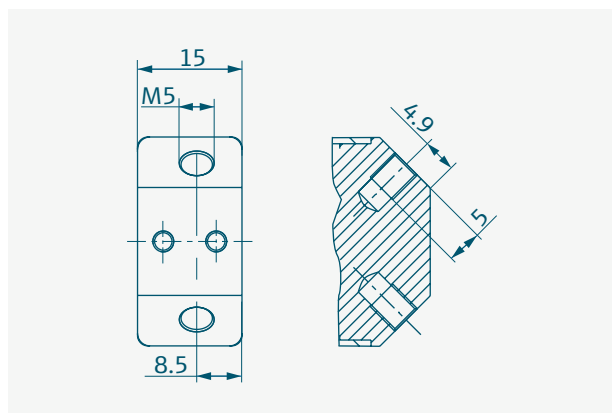

Dimensions in mm for fluid installation

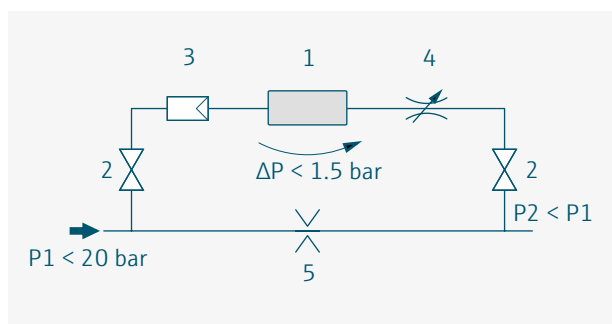

Installation example: 1 = Viscosity sensor; 2 = Valve; 3 = Filter; 4 = Flow restrictor; 5 = Orifice

Making the electrical connections for the viscosity sensor

⚠ WARNING

Death or severe injury due to incorrect connection

- ▶ Electrical connection work may be carried out by correspondingly trained specialist personnel only.
- ▶ Observe installation codes and requirements valid in the respective country.
- ▶ Comply with local occupational safety requirements.

⚠ WARNING

No current-limiting fuse

- ▶ Ensure overcurrent protection ($I_{\max} = 500 \text{ mA}$) through external circuit.

⚠ WARNING

Use in areas with an explosion hazard

The viscosity sensor VLO-M2 has no approval for use in hazardous areas.

- ▶ When operating in areas with an explosion hazard, ensure explosion protection.
- ▶ Connect the viscosity sensor to the higher-level system. In doing so, note the cable assignment, see „Kabelbelegung“ auf Seite 11.

NOTICE

RS-485 point-to-point connection

- ▶ The variant VLO-M2_ex is designed for a RS-485 point-to-point connection.
- ▶ Variant VLO-M2_ex: On the client side a 330 Ω termination resistor must be used between the RS-485 lines (D0 and D1).

The serial interface is based on the "Modbus over serial line" specification.

Integrating the viscosity sensor into the system

The viscosity sensor sends the measured data to the readout system via the data line in Modbus RTU transmission mode. General settings of the serial Modbus RTU interface:

NOTICE

- ▶ Modbus RTU protocol implemented according to specification V1.1b3
- ▶ Modbus registers refer to the start value 0
- ▶ For the sensor the typical response time is 10...20 ms
- ▶ For further Modbus information see section Modbus

NOTICE

The viscosity sensor does not include a pressure sensor.

Switching on the viscosity sensor

- ▶ Switch on the power supply. After the power supply is switched on, the viscosity sensor starts automatically after an initialization routine.



Uninstalling the viscosity sensor

⚠ WARNING

Danger to personnel and environment from media that are hazardous to health

- ▶ Ensure that no media hazardous to health or the environment can escape when loosening the fluid connection.
- ▶ Ensure that no residues of hazardous substances can escape from the viscosity sensor when the mechanical fastenings are loosened by changing their position.

1. Disconnect the cable connections of the electrical connections from the viscosity sensor.
2. Disconnect the fluid connections.
3. Undo the mechanical fastening.

Cleaning and repair

Carrying out cleaning of the housing

NOTICE

Cleaning agents may cause damage to the housing

- ▶ Do not use high-pressure steam.
- ▶ Use only permitted cleaning agents.
- ▶ Permitted cleaning agents:
 - Mild soap solutions
 - Methyl or isopropyl alcohol
 - Water

Carrying out cleaning of the microchannel

NOTICE

Damage to the microchannel possible

- ▶ Use only permitted cleaning agents.

1. Flush with permitted cleaning agents.
Permitted cleaning agents:
 - isopropanol (IPA), ethanol, petroleum ether (e.g. petroleum 80 to 110), acetone and hexane
2. Then, flush with dry air until there is no more cleaning agent in the microchannel.
3. Fill the viscosity sensor with fluid with a known density value. Deviations from the nominal density value that are greater than the specified maximum measuring deviation indicate residues in the microchannel.

Disposal

Disposing of the viscosity sensor

⚠ WARNING

Danger to personnel and environment from media that are hazardous to health

- ▶ Ensure that the viscosity sensor and all cavities are free of any residues of the measuring medium that are hazardous to health or the environment.
- ▶ Send viscosity sensor components for recycling. Observe codes and requirements valid in the respective country.

Product specification

General

Measured variable Viscosity, density and variables derived from it (e.g. standard density, concentration, etc.)

Permitted media

NOTICE

Damage to the microchannel possible.

- ▶ Do not use helium.

Particle-free (<30 µm) hydrocarbons e.g.

- Gasoline E5 / E10 / E85
- Diesel B7 / B10 / XTL
- Jet-A1 (also F-35 or JP-8)
- M100 (methanol)
- Isopropanol
- OME* (synthetic fuel)
- LPG*

Aqueous media such as:

- AdBlue®*
- Glycol blends*

Additional media can be used after individual clarification where applicable. *Optional



Measurement performance

Max. measurement deviation

- Viscosity: $\pm[0,2 \text{ mPa s} + 5\% \text{ from measurement}]$
- Density: ± 0.2 or $\pm[0.0075 \times \text{abs}(T-25^\circ\text{C})]$ °C if the value is >0.2
- Temperature: ± 0.15 or $\pm[0.005 \times \text{abs}(T-25^\circ\text{C})]$ °C if the value is >0.15

NOTICE

Pressure-dependent density measurement accuracy

The viscosity sensor is calibrated to 1 bar (abs) by default. At higher pressure the viscosity sensor indicates a density that is too low. At pressure change Δp , the density deviation is $\Delta \rho$:

$$\Delta \rho = (0.07 \pm 0.02) \frac{\text{kg}}{\text{m}^3 \cdot \text{bar}} \cdot \Delta p$$

- ▶ Note pressure-dependent density measurement accuracy.
- ▶ If necessary, correct the measured density value due to the influence of pressure:

$$\rho_{\text{Fluid}} = \rho_{\text{mess}} + \Delta \rho$$

Here, ρ_{Fluid} is the actual density at process pressure and ρ_{mess} is the density measured by the viscosity sensor.

- ▶ Order option: Calibration to desired pressure (1 to 20 bar (abs)).

Repeatability

- Viscosity: $\pm 0,1 \text{ mPa s}$
- Density: $\pm 0.1 \text{ kg/m}^3$
- Temperature: $\pm 0.05^\circ\text{C}$

Temperature conditions

Permitted medium temperature -40 to +60 °C

Permitted ambient temperature -40 to +60 °C

Permitted storage temperature -40 to +60 °C

Area of application

Permitted measured density value 600 to 1000 kg/m³
(Optionally 0 to 1200 kg/m³)

Permitted viscosity range 0.3 to 5 mPa s
(Optionally 0.3 to 50 mPa s)

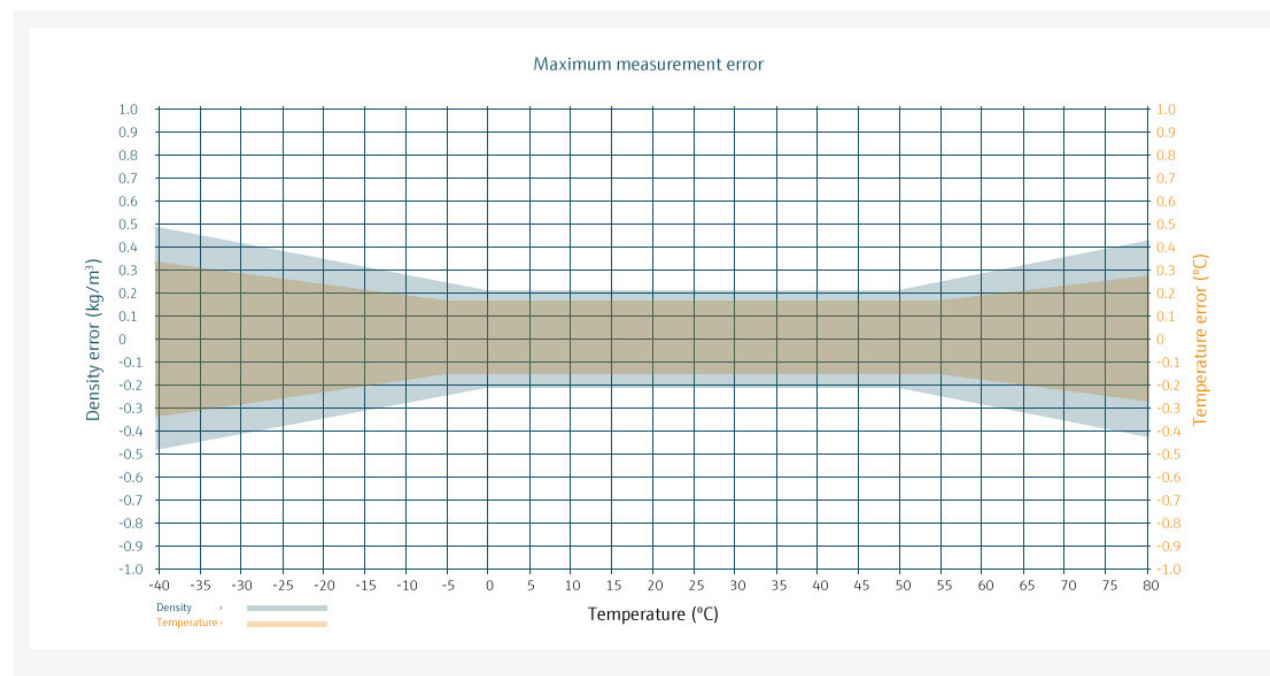

Max. measurement deviation: Density and temperature



Permitted medium density	0 to 20 bar (abs) Burst pressure 80 bar (abs)
Permitted particle size	Max. 30 µm
Permitted flow range	0 to 10 l/h
Vibrations	Vibrations (<20 kHz) have no influence on the measuring accuracy due to the high working frequency of the microchannel.
Inlet and outlet runs	Inlet and outlet runs have no influence on the measuring accuracy.
	NOTICE Permissible means that the measuring accuracy of the sensor is within the given specifications.
Flow/pressure loss conditions	NOTICE To ensure proper operation, the flow rate (Q) must not exceed 10 l/h.
Units	[K _v]= m ³ /h, [Q]=l/h, [Δp]=bar, [ρ]=kg/m ³ , [η]= mPa s

Flow/pressure loss conditions

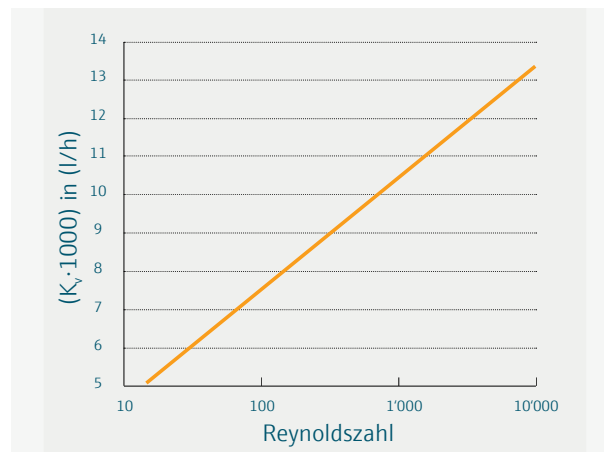

Flow factor versus Reynolds number ($K_v (Re) = [1.28 \ln (Re) + 1.60] \pm 10\%$)

Determining the flow factor (K_v · 1000 l/m³)
The flow factor can be read by means of the Reynolds number (Re) via the Fig. Flow / pressure loss conditions.

Determination of Re via Q, ρ and η
$$Re \cong \frac{Q \cdot \rho}{2 \cdot \eta}$$

Determination of Q via Δp
$$Q = K_v \cdot 1000 \text{ l/m}^3 \sqrt{\frac{\Delta p}{1 \text{ bar}} \cdot \frac{1000 \text{ kg/m}^3}{\rho}}$$

Determination of Δp via Q
$$\Delta p = \left(\frac{Q}{K_v \cdot 1000 \text{ l/m}^3} \right)^2 \cdot \frac{\rho}{1000}$$

Calculation
If one of the needed factors such as Q is not available, several iteration steps are needed.

Response time

- The density is recorded with a measuring rate of at least 30 Hz. As a result of internal processing and filtering, the maximum group delay is 1 s.
- The temperature is recorded with a measuring rate of 2 Hz. As a result of internal processing and filtering, the maximum group delay is 2.5 s.

Ambient conditions

Climate class
In accordance with:

- IEC/EN 60068-2-1
- IEC/EN 60068-2-2
- IEC/EN 60068-2-30

Electromagnetic compatibility
EMC 2014/30/EU (EN 61326-1)

Vibration and shock resistance
In accordance with:

- IEC/EN 60068-2-6
- IEC/EN 60068-2-27
- IEC/EN 60068-2-64

Protection class
IP54 (IEC 60529)



Materials

Housing

- Stainless steel:
 - 1.4404 (316L)
 - 1.4542 (AISI/SUS 630)

Wetted parts

- Stainless steel:
 - 1.4542 (AISI/SUS 630)
- BOROFLOAT® 33 glass
- Silicon
- Epoxy resin

Dimensions

Dimensions

30 x 66 x 15 mm³ (without cable, cable gland and connection for protective ground)

Weight

<200 g

Dimensions of measurement channel

160 x 200 µm (500 nl)

Fluid interface

Fluid interfaces

2 x M5 threaded holes at a 45° angle to the side and front surface

Electrical interface

Cable design

Permanently installed cable. Connecting cable type KS-Li-9YD11Y 4xAWG 28, manufacturer: Kabel Sterner

Cable length

3 m (optionally up to 20 m)

Cable outer diameter

2.3 mm

Wire diameter

4 x AWG 28

Level control

Digital communication lines and power supply in one common shielded cable

- Unidirectional, RS-485

NOTICE

For the variant VLO-M2_ex

- ▶ Provide a 330 Ω termination resistor on the client side (see Page 6)

For the variant VLO-M2

- ▶ For the integration in RS485-Modbus a bus termination according to specification "Modbus over serial line V1.02" has to be provided.

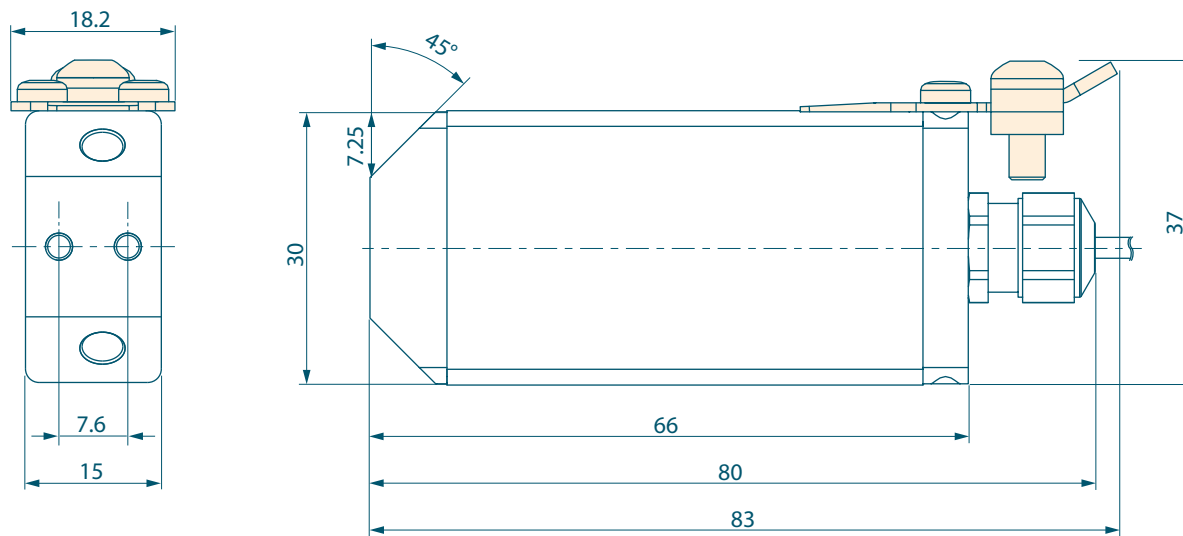

Design, dimensions in mm
(orange range valid only for VLO-M2_ex)



Energy supply	Maximum current draw 26 mA, maximum power consumption 350 mW.
	<p>NOTICE</p> The power supply unit must be safety tested (e.g. PELV, SELV). For the variant DLO-M2_ex
	<ul style="list-style-type: none"> ▶ Supply: 9.4 V to 13.3 V (typical: 12 V)
	For the variant DLO-M2 (non-ex)
	<ul style="list-style-type: none"> ▶ Supply: 5 V ... 13.3 V
	<p>⚠ WARNING</p> For DLO-M2_ex, observe safety instructions DB-KU-100206-*. The asterisk (*) stands for the version.
	<ul style="list-style-type: none"> ▶ Zener barriers (supply and RS485)
Dielectric strength	Version VLO-M2_ex
	The reference potential (GND) is connected to the housing and the ground connection (see product design). There is no galvanic isolation between the supply circuits, the communication interface and GND.

Dielectric strength (continued)	Version VLO-M2 (non-ex)										
	There is a capacitive coupling between the reference potential (GND) and the housing (ground). The dielectric strength is 50 V. There is no galvanic isolation between the supply circuits, the communication interface and GND.										
	The cable shield is connected to the sensor housing. The shield must be connected to the protective earth on the connection side according to the "Modbus over serial line V1.02" specification.										
Cable assignment	<table border="1"> <thead> <tr> <th>Wire color</th> <th>Assignment</th> </tr> </thead> <tbody> <tr> <td>yellow</td> <td>RS485 B, D1</td> </tr> <tr> <td>green</td> <td>RS485 A, D0</td> </tr> <tr> <td>brown</td> <td>GND (signal ground), common</td> </tr> <tr> <td>white</td> <td>V_{DD} (supply voltage)</td> </tr> </tbody> </table>	Wire color	Assignment	yellow	RS485 B, D1	green	RS485 A, D0	brown	GND (signal ground), common	white	V _{DD} (supply voltage)
Wire color	Assignment										
yellow	RS485 B, D1										
green	RS485 A, D0										
brown	GND (signal ground), common										
white	V _{DD} (supply voltage)										
	<p>NOTICE</p> The wire color code does not comply with the "Modbus over serial line V1.02" specifications										

Certificates and approvals

CE marking The viscosity sensor meets the legal requirements of the EC directives. TrueDyne Sensors AG confirms the successful testing of the viscosity sensor with the attachment of the CE mark.

IECEX, ATEX



WARNING
Applies for the VLO-M2_ex version

Depending on the version, the product complies with the following directives:

		VLO-M2	VLO-M2_ex
ATEX	2014/34/EU(L96/309)		✓
LVD	2014/35/EU(L96/357)	✓	✓
EMC	2014/30/EU (L96/79)	✓	✓
RoHS	2011/65/EU(L174/88)	✓	✓

The following standards are complied with:

	VLO-M2	VLO-M2_ex
EN 61010-1: 2010	✓	✓
EN IEC 60079-0: 2019		✓
EN 60079-11: 2012		✓
EN 61326-1: 2013	✓	✓
EN 61326-2-3: 2013	✓	✓
EN 50581: 2012	✓	✓



Legal restrictions

Fields of industry The viscosity sensor cannot be used in the following fields of industry for legal reasons:

- Military (any applications in the military field whatsoever, including airplanes, vehicles or military structures. This does not include fuel delivery and fuel dispensing when refueling on the ground)
- Aerospace (applications in flying objects of any kind. Excluded from this is fuel delivery and fuel dispensing when refueling on the ground)
- Fuel cells (use in stationary or mobile fuel cells)
- Medical devices (objects or substances used for medical purposes for human beings - the pharmaceutical industry is not affected)

Modbus

Default settings:

Baud rate	19200 BAUD
Data bits	8
Parity	Even
Byte order	1-0-3-2
Stop bits	1 bit

Modbus

Modbus address	247
FlowControl	None (0)
Transmission type	Modbus RTU (protocol)
Temperature unit	°C
Pressure unit	bar
Density unit	kg/m ³
Dynamic viscosity unit	mPa s
Kinematic viscosity unit	mm ² /s

NOTICE

- ▶ *Values are only visible with the corresponding software option

The following Modbus RTU functions are supported:

Code	Name	Description
0x01	Read Coils	Read one or more coils
0x03	Read Holding Registers	Read a consecutive holding register block
0x04	Read Input Registers	Read one or more successive registers
0x05	Write Single Coil	Write one coil
0x06	Write single register	Write one single register

0x0F	Write Multiple Coils	Write multiple successive coils
0x10	Write Multiple Registers	Write multiple successive registers

NOTICE

The following Modbus RTU functions are not supported

- ▶ 0x02 Read Discrete Inputs
- ▶ 0x07 Read Exception Status
- ▶ 0x08 Diagnostics
- ▶ 0x0B Get Comm Event Counter
- ▶ 0x0C Get Comm Event Log

When addressing the devices, it is essential to ensure that there are not two devices with the same address. In such a case an abnormal behavior of the whole serial bus can occur, because the master is then no longer able to communicate with all existing slaves on the bus.

Compared to the "Modbus over serial line V1.02" protocol there are following differences

- ▶ 3.6 Cables - The cable strands are not twisted together.
- ▶ 3.7 Visual Diagnostics - There is no LED display on the sensor.
- ▶ "Line Polarization" is not necessary for the sensor and is not provided.

Min. 32 sensors are supported in the bus system.)



Modbus Register Informationen

Info

Name	Address	Data type	Selection/input	Operator	Maintenance
Memory Version	100	UINT16		r	r
Serial Number	101 ...107	STRING14		r	r
Software Version	108	UINT16		r	r
Software Build	109	UINT16		r	r
Pin	110 ...117	STRING16		r	r
Devie Identity	1	UINT16		r	r
Device Name	7262 ...7269	STRING16		r	r
Firmware Version	7276 ...7279	STRING8		r	r
Access status tooling	2177	UINT16	0: Operator 1: Maintenance 2: Service (nur TrueDyne)	r	r

Config

Modbus

Name	Address	Data type	Selection/input	Operator	Maintenance
Modbus address	4909	UINT16	1 ...247	r	r/w
Baud rate	4911	UINT16	3: 9600 4: 19200 5: 38400 6: 57600 7: 115200	r	r/w
Parity	4913	UINT16	0: None / 2 stop bits 1: Even / 1 stop bit 2: Odd / 1 stop bit 3: None / 1 stop bit	r	r/w
Byte order	4914	UINT16	0: 0-1-2-3 1: 3-2-1-0 2: 2-3-0-1 3: 1-0-3-2	r	r/w

r = read / w = write / Modbus registers refer to the start value 0



Device

Name	Address	Data type	Selection/input	Operator	Maintenance
Software option	2794	UINT16	0: Density 1: Viscosity 2: Concentration&Density (Option) 3: Concentration&Viscosity (Option)	r	r
Application option	2795	UINT16	0: Off 1: Sugar, Fructose in Water, Glucose in Water, Sucrose in Water, Invert Sugar in Water, HFCS42, HFCS55, HFCS90 2: Alcohol, Ethanol in Water_OIML, Methanol in Water 3: Alcohol (viscosity), Ethanol in Water_OIML, Methanol in Water, Ethyleneglycol in Water 4: Distillery & Brewery, Ethanol in Water_OIML, Fructose in Water, Glucose in Water, Sucrose in Water, Invert Sugar in Water	r	r

Application option (continued)	2795	UINT16	5: Saline, Sodium Chloride in Water, TDS in Water 6: H2O2, Hydrogen Peroxide in Water 7: User	r	r
---------------------------------------	------	--------	---	---	---

NOTICE

Software options

► The desired software option must be specified when ordering.

Restart Device	6816	UINT16	0: False 1: True	r/w	r/w
Device Tag	4900 ...4907	STRING16	Free selectable	r	r/w
Enter Access code	2176	UINT16	0...65535 For maintenance 8646	r/w	r/w
FB User Level	2179	UINT16	0: Operator 1: Maintenance 2: Service (only TrueDyne)	r	r/w

r = read / w = write / Modbus registers refer to the start value 0



Sensor

Name	Address	Data type	Selection/input	Operator	Maintenance
Pressure value	5184 ...5185	FLOAT32		r	r/w

NOTICE

- ▶ The density sensor does not include a pressure sensor.
- ▶ Pressure value can be written via Modbus.
- ▶ Frequent writing of pressure values can lead to memory corruption in the EEPROM..

Pressure unit	2129	UINT16	0: bar abs 1: bar gauge 2: psi abs 3: psi gauge 4: kPa abs 5: kPa gauge	r	r/w
Density unit	2106	UINT16	0: g/cm ³ 1: g/cc 2: kg/l 3: kg/m ³ 4: lb/ft ³ 5: lb/gal 6: Specific gravity	r	r/w

NOTICE

- ▶ Specific gravity (SG) is calculated with the current temperature.

$$SG = \frac{\rho_{\text{medium}}(T)}{\rho_{\text{water}}(T)}$$

Temperature unit	2108	UINT16	0: °C 1: K 2: °F 3: °R	r	r/w
Dynamic viscosity unit	2110	UINT16	0: cP 1: P 2: Pa s 3. mPa s	r	r/w
Kinematic viscosity unit	2111	UINT16	0: m ² /s 1: mm ² /s 2: cSt 3: St	r	r/w
Density single point	205 ...206	FLOAT32		r	r/w
Density offset	5528 ...5529	FLOAT32		r	r/w
Reset density offset	207	UINT16	0: Off 1: Reset	r	r/w
Viscosity single point	208 ...209	FLOAT32		r	r/w
Viscosity offset	5530 ...5531	FLOAT32		r	r/w
Reset viscosity offset	210	UINT16	0: Off 1: Reset	r	r/w
Single point adjustment	2510	UINT16	0: Off 1: Water	-	r/w

r = read / w = write / Modbus registers refer to the start value 0



MinMaxValues

Name	Address	Data type	Selection/input	Operator	Maintenance
LowerBoundDensityRange	2600 ...2603	FLOAT32		r	r
UpperBoundDensityRange	2604 ...2607	FLOAT32		r	r
LowerBoundTemperatureRange	2608 ...2611	FLOAT32		r	r
UpperBoundTemperatureRange	2612 ...2615	FLOAT32		r	r
LowerBoundPressureRange	2616 ...2619	FLOAT32		r	r
UpperBoundPressureRange	2620 ...2623	FLOAT32		r	r
LowerBoundConcentrationRange	2624 ...2627	FLOAT32		r	w
UpperBoundConcentrationRange	2628 ..2631	FLOAT32		r	w
LowerBoundViscoRange	2632 ...2635	FLOAT32		r	r
UpperBoundViscoRange	2636 ...2639	FLOAT32		r	r

NOTICE

- ▶ The LowerBoundViscoRange and the UpperBoundViscoRange are only visible with the software option Viscosity and Concentration&Viscosity.
- ▶ The LowerBoundConcentrationRange and the UpperBoundConcentrationRange are only visible with the Concentration&Density and Concentration&Viscosity software option.

Concentration

Name	Address	Data type	Selection/input	Operator	Maintenance
LiquidType	26491	UINT16	0: Off 1: Fructose in water 2: Glucose in water 3: Sucrose in water 4: Invert sugar in water 5: Hydrogen Peroxid in water 6: Ethanol in water (OIML) 7: Methanol in water 8: Etylen glycol in water 9: HFCS42 10: HFCS55 11: HFCS90 12: Sodium chloride in water 13: TDS in water 14: User coeffs	r	r
User concentration text	2584 ...2588	STRING10		r	r
Concentration unit	2438	UINT16	0: SGU 1: °Brix 2: °Balling 3: Proof/Vol 4: %Vol 5: %Vol@20°C 6: °Plato 7: mol/l 8: %ABV@20°C 9: %mass	r	w

r = read / w = write / Modbus registers refer to the start value 0



Concentration unit (continued)	2438	UINT16	10: mg/l 11: %StdVol 12: User conc.	r	w
A0	28485 ...28488	FLOAT32		r	r
A1	28491 ...28494	FLOAT32		r	r
A2	28497 ...28500	FLOAT32		r	r
A3	28509 ...28512	FLOAT32		r	r
A4	28521 ...28524	FLOAT32		r	r
B1	28503 ...28506	FLOAT32		r	r
B2	28515 ...28518	FLOAT32		r	r
B3	28527 ...28530	FLOAT32		r	r
D1	25864 ...25867	FLOAT32		r	r
D2	28570 ...28573	FLOAT32		r	r
D3	28576 ...28579	FLOAT32		r	r
D4	28582 ...28585	FLOAT32		r	r

NOTICE

- ▶ The Concentration values are only visible with the Concentration&Density and Concentration&Viscosity software options.
- ▶ User concentration text and user coeffs. A0 ... D4 cannot be written by the user. Only possible by TrueDyne (service).
- ▶ The Liquid types are grouped in different application packages.

Process Variable

Name	Adresse	Datentyp	Auswahl/ Eingabe	Operator	Maintenance
Density	2012 ...2013	FLOAT32		r	r
Density compensated	2030 ...2031	FLOAT32		r	r
Temperature	2016 ...2017	FLOAT32		r	r
Pressure	2088 ...2089	FLOAT32		r	r
Dynamic viscosity	2018 ...2019	FLOAT32		r	r
Kinematic viscosity	2082 ...2083	FLOAT32		r	r
*Concentration	2597 ...2598	FLOAT32		r	r

NOTICE

- ▶ *Values are only visible with the corresponding software option

r = read / w = write / Modbus registers refer to the start value 0



Status

Name	Adresse	Datentyp	Auswahl/ Eingabe	Operator	Mainte- nance
Density OK	12	UINT16	0: False 1: True	r	r
Temperature OK	14	UINT16	0: False 1: True	r	r
Pressure OK	15	UINT16	0: False 1: True	r	r
*Concentration OK	16	UINT16	0: False 1: True	r	r
Tube oscillation OK	13	UINT16	0: False 1: True	r	r
Viscosity OK	17	UINT16	0: False 1: True	r	r

NOTICE

► *Values are only visible with the corresponding software option



Download area

On our website www.truedyne.com you will find this document and other useful documents in our download area.

Documents and files

Product information

- Data sheet
- Safety notes
- Data sheet
- STEP file
- Calibration certificate (optional)

Declarations of conformity

- CE marking EU declaration of conformity
- RoHS III EU declaration of conformity

Training courses

- Basics of density measurement training



https://www.truedyne.com/VLO-M2_ex_download_en



https://www.truedyne.com/VLO-M2_download_en



Website

Are you looking for more innovative sensors for density and viscosity? Visit our website www.truedyne.com and learn more about our current product portfolio

Product portfolio

Sensors for measuring fluids

For example:

- DLO-M2 viscosity sensor
- VLO-M2 viscosity and viscosity sensor

Sensors for measuring gases

- DGF-I1 viscosity sensor
- Nanomass viscosity sensor



- www.truedyne.com

