

## Data sheet | Technical Description and Installation Instructions

Document number: DB-KU-100113-6      From firmware version: V2.03.00

Initial creation: March 2023      From serial number: xxx1318



DML02 | DML02\_ex version:

Density sensor DLO-M2 | DLO-M2\_ex



## Contents

Notes about the data sheet	3
Safety notes	3
Product description	4
Installation, start-up and uninstallation	5
Cleaning and repair	7
Disposal	7
Product specification	7
Modbus	12
Download area	18
Website	19



## Notes about the data sheet

### Use and safekeeping

- This data sheet is an integral component of the density sensor.
- Keep the data sheet in the immediate vicinity of the place of use.
- In case of transfer to third parties, pass on the data sheet or relevant content to them.
- Read the data sheet carefully.
- We reserve the right to make changes.

#### **⚠ WARNING**

#### Use of the DLO-M2\_ex version

This document is only valid in connection with the DLO-M2\_ex with the safety instructions DB-KU-100206-\*. The asterisk (\*) stands for the version.

### Function

The data sheet provides information for safe use and installation of the density sensor.

### Symbols used

The following symbols are used in the data sheet to draw attention to dangerous situations and to indicate instructions for action:

Symbol	Description
<b>⚠ WARNING</b>	Leads to death or serious injury if not avoided.
<b>NOTICE</b>	Information on facts that do not involve physical injury.
▶	Single-step handling instruction
<b>1. / 2. / 3.</b>	Multi-step handling instruction

## Safety notes

### Intended use

- Depending on the ordered version, the measuring instrument can also measure explosive and inflammable media.
- Measuring instruments for use in hazardous areas are specially marked on the type plate.
- The density sensor is to be used exclusively for measuring the density of fluids. Only permitted media may be used.
- Check by means of the type plate whether the ordered measuring instrument can be used for its intended purpose in the area relevant for approval (e.g. explosion protection).
- Failure to observe the area of application can impair safety. The manufacturer shall not be held liable for damage arising from improper use.

### Qualification of personnel

- The density sensor may be installed by specialist personnel only.

### Operating safety

- The owner/operator is responsible for interference-free operation of the density sensor.
- Only operate the density sensor in a technically perfect and safe operating condition.
- In case of increased medium temperature, ensure protection against accidental contact to avoid burns.
- Unauthorised modifications or repairs to the density sensor are not permitted and can lead to unforeseeable dangers.

### Product safety

- The density sensor complies with the guidelines listed in the EU Declaration of Conformity. By affixing the CE mark, TrueDyne Sensors AG confirms this fact.



## Product description

### Overview

The density sensor was designed for measuring the density of fluids. This takes place using a microelectromechanical system (MEMS) with a microchannel shaped like the Greek letter omega (omega chip), which is built into an internal bypass.

When the medium flows through the density sensor, the bypass arrangement generates a pressure gradient via the microchannel, which allows the medium to reach the omega chip. The medium influences the physical properties of the excited sensor (resonance frequency and quality), and these are digitised and evaluated in the microcontroller. The measured values can be read out via the serial interface (RS-485, Modbus).

Thus, density measurements in the range of 0...1200 kg/m<sup>3</sup> at a flow rate of 0...10 l/h can be realised.

Further options are available regarding an extended density range, viscosity measurement and density measurement of gases. The specifications can be found in the corresponding documentation.

### Omega chip

The omega chip, a vibronic microsystem, is the heart of the measuring system and is used for sensor signal

generation in the overall system. An essential component of this microsystem is a silicon tube (microchannel), which is electrostatically set into oscillation in a vacuum atmosphere. To compensate for temperature effects, a platinum resistor is integrated, which allows local real-time temperature measurement. The omega chip essentially consists of crystalline silicon and glass.

### Density measurement

The density sensor uses the omega chip for density measurement. For this purpose, the filled microchannel is brought to resonant oscillation and analysed.

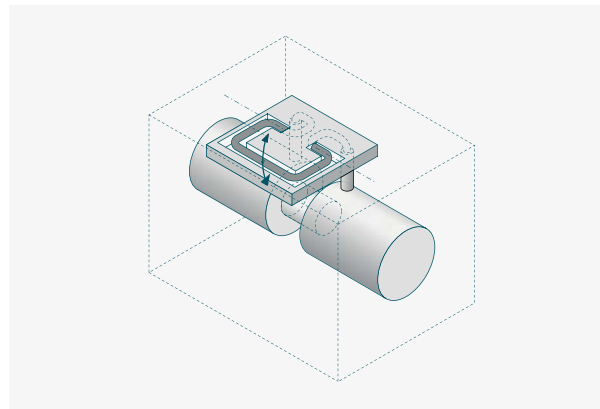

*Measuring principle (omega chip)*

The resulting resonant frequency of the microchannel depends on the mass and thus on the density of the medium in the microchannel: The greater the density of the medium, the lower the resonant frequency. Thus

the resonant frequency is a function of the medium density.

$$f \propto \sqrt{\frac{E \cdot I}{\rho_{\text{Tube}} \cdot A_{\text{Tube}} + \rho_{\text{Fluid}} \cdot A_{\text{Fluid}}}}$$

*f = resonant frequency, E · I = stiffness of the tube,  $\rho_{\text{Tube}}$  = tube density,  $A_{\text{Tube}}$  = tube cross-section,  $\rho_{\text{Fluid}}$  = medium density,  $A_{\text{Fluid}}$  = medium cross-section*

### Possible applications

The density sensor can be used for direct and indirect density measurements. While a product property or quality can be determined with the direct density measurement, an indirect density measurement using tables and calculation algorithms makes it possible to determine the concentration of fluid mixtures.

The density sensor can be used in the following applications, for example:

- Supplement volumetric flow measurement in orifice plates, turbines or displacement devices to enable mass measurement. The density sensor takes into account temperature changes and thereby takes temperature measurements into account. It is also possible to write the externally measured pressure into the density sensor (see special documentation for gas measurement).



- Monitoring and controlling the quality of fuel mixtures such as E10 or biodiesel.

## Product design

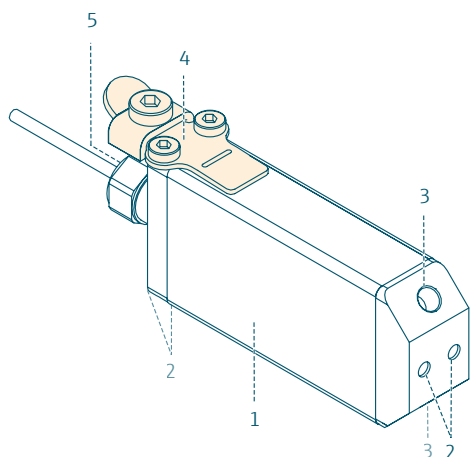

### Product design of density sensor DLO-M2 | DLO-M2\_ex

- Density sensor DLO-M2(\_ex)
- Mounting holes for mechanical fastening (6 x M3 threaded holes)
- Fluid interface (2 x M5 threaded holes)
- Clamp on grounding plate with screws M3x6 TORX
- Electronic interface for communication and power supply

### NOTICE

For the DLO-M2 (non-ex), item 4 (clamp on grounding plate with screws M3x6 TORX) is not applicable. Marked orange in the graphic.

## Scope of delivery

- Density sensor (including transport safety devices)

## Product identification

The density sensor is identified by a consecutive, eleven-digit serial number. This is installed on the outside of the housing and can also be viewed via Modbus.

## Installation, start-up and uninstallation

### Fastening the density sensor mechanically

- Fix the density sensor with M3 screws using the provided mounting holes (4 mm depth). Maximal tightening torque 30 cNm (typically 15 to 20 cNm)

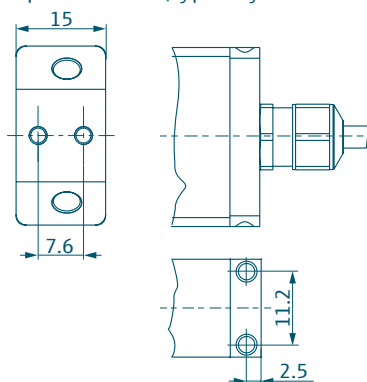

Dimensions in mm for mechanical fastening

### Making the fluid connections for the density sensor

- With a flow rate >10 l/h, installation in a bypass line is recommended to limit the flow rate through the density sensor to <10 l/h.
- The bypass line can be led to a collecting tank or back to the main line.

### WARNING

#### Danger of injury due to dangerous process conditions and pipe break

- Empty and depressurize the pipeline before installing the density sensor.
- Take high temperatures into account.
- If necessary, fasten the density sensor mechanically.

### NOTICE

#### Clogging of the microchannel

- If necessary, install a filter upstream of the density sensor to prevent the microchannel from clogging.

### NOTICE

#### Delayed measurement signal for installation in bypass

- Note the time delay, for example for open-loop process control.

- Remove all remaining packaging materials.
- Remove transportation safety devices on fluid connections.



- Install the density sensor at fluid connections with M5 connectors (thread depth 5 mm) in the pipeline, whereby flow and installation direction are not relevant. Also follow the instructions in the operating manual of the connector used.

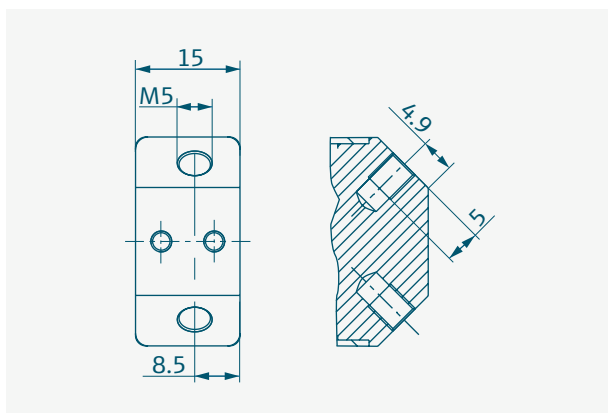

Dimensions in mm for fluid installation

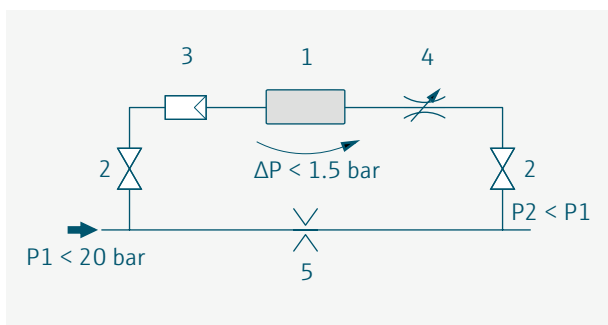

Installation example: 1 = Density sensor; 2 = Valve; 3 = Filter; 4 = Flow restrictor; 5 = Orifice

### Making the electrical connections for the density sensor

#### ⚠ WARNING

#### Death or severe injury due to incorrect connection

- ▶ Electrical connection work may be carried out by correspondingly trained specialist personnel only.
- ▶ Observe installation codes and requirements valid in the respective country.
- ▶ Comply with local occupational safety requirements.

#### ⚠ WARNING

#### No current-limiting fuse

- ▶ Ensure overcurrent protection ( $I_{\max} = 500 \text{ mA}$ ) through external circuit.

#### ⚠ WARNING

#### Use in areas with an explosion hazard

The density sensor DLO-M2 (non-ex) has no approval for use in hazardous areas.

- ▶ When operating in areas with an explosion hazard, ensure explosion protection.
- ▶ Connect the density sensor to the higher-level system. Observe the cable assignment, see "Cable assignment" on page 11.

#### NOTICE

#### RS-485 point-to-point connection

- ▶ The variant DLO-M2\_ex is designed for a RS-485 point-to-point connection.
- ▶ Variant DLO-M2\_ex: On the client side a 330 Ω termination resistor must be used between the RS-485 lines (D0 and D1).

- ▶ The serial interface is based on the "Modbus over serial line" specification.

### Integrating the density sensor into the system

The density sensor sends the measured data to the readout system via the data line in Modbus RTU transmission mode. General settings of the serial Modbus RTU interface:

#### NOTICE

- ▶ Modbus RTU protocol implemented according to specification V1.1b3
- ▶ Modbus registers refer to the start value 0
- ▶ For the sensor the typical response time is 10...20 ms
- ▶ For further Modbus information see section Modbus

#### NOTICE

The density sensor does not include a pressure sensor. However, it is possible to the possibility of writing the externally measured pressure into the density sensor (see special documentation for gas measurement). gas measurement)..

### Switching on the density sensor

- ▶ Switch on the power supply. After the power supply is switched on, the density sensor starts automatically after an initialization routine.



## Uninstalling the density sensor

### **⚠ WARNING**

#### **Danger to personnel and environment from media that are hazardous to health**

- ▶ Ensure that no media hazardous to health or the environment can escape when loosening the fluid connection.
- ▶ Ensure that no residues of hazardous substances can escape from the density sensor when the mechanical fastenings are loosened by changing their position.

1. Disconnect the cable connections of the electrical connections from the density sensor.
2. Disconnect the fluid connections.
3. Undo the mechanical fastening.

## Cleaning and repair

### Carrying out cleaning of the housing

#### **NOTICE**

#### **Cleaning agents may cause damage to the housing**

- ▶ Do not use high-pressure steam.
- ▶ Use only permitted cleaning agents.
- ▶ Permitted cleaning agents:
  - Mild soap solutions
  - Methyl or isopropyl alcohol
  - Water

### Carrying out cleaning of the microchannel

#### **NOTICE**

#### **Damage to the microchannel possible**

- ▶ Use only permitted cleaning agents.

1. Flush with permitted cleaning agents.  
Permitted cleaning agents:
  - isopropanol (IPA), ethanol, petroleum ether (e.g. petroleum 80 to 110), acetone and hexane
2. Then, flush with dry air until there is no more cleaning agent in the microchannel.
3. Fill the density sensor with fluid with a known density value. Deviations from the nominal density value that are greater than the specified maximum measuring deviation indicate residues in the microchannel.

## Disposal

### Disposing of the density sensor

#### **⚠ WARNING**

#### **Danger to personnel and environment from media that are hazardous to health**

- ▶ Ensure that the density sensor and all cavities are free of any residues of the measuring medium that are hazardous to health or the environment.
- ▶ Send density sensor components for recycling. Observe codes and requirements valid in the respective country.

## Product specification

### General

**Measured variable** Density and variables derived from it (e.g. standard density, concentration, etc.)

### Permitted media

#### **NOTICE**

#### **Damage to the microchannel possible.**

- ▶ Do not use helium.

Particle-free (<30 µm) hydrocarbons e.g.

- Gasoline E5 / E10 / E85
- Diesel B7 / B10 / XTL
- Jet-A1 (also F-35 or JP-8)
- M100 (methanol)
- Isopropanol
- OME\* (synthetic fuel)
- LPG\*

Aqueous media such as:

- AdBlue®\*
- Glycol blends\*

Additional media can be used after individual clarification where applicable.

Various gases:

- See special documentation DLO-M2 | DLO-M2\_ex density sensor for gases.



### Measurement performance

#### Max. measurement deviation for liquids

(For gases, see special documentation for gases.)

- Density:  $\pm 0.5 \text{ kg/m}^3$
  - Temperature:  $\pm 0.3 \text{ }^\circ\text{C}$
- Option
- Density:  $\pm 0.2 \text{ kg/m}^3$  or  $\pm [0.0075 \times \text{abs}(T-25 \text{ }^\circ\text{C})] \text{ kg/m}^3$  if the max. measurement deviation is  $> 0.2 \text{ kg/m}^3$
  - Temperature:  $\pm 0.15 \text{ }^\circ\text{C}$  or  $\pm [0.005 \times \text{abs}(T-25 \text{ }^\circ\text{C})] \text{ }^\circ\text{C}$ .

#### NOTICE

#### Pressure-dependent density measurement accuracy

These specifications are in relation to measurements of liquids. For gas measurements see special documentation. The measured values are referred to 1.01325 bar (abs) as standard. A parameterisation to another pressure by order or by own parameterisation is also possible. At higher pressure, the density sensor indicates a too low density. The density deviation  $\Delta\rho$  is  $\Delta p$  with pressure change:

$$\Delta\rho = (0.07 \pm 0.02) \frac{\text{kg}}{\text{m}^3 \cdot \text{bar}} \cdot \Delta p$$

- ▶ Note pressure-dependent density measurement accuracy.
- ▶ If necessary, correct the measured density value due to the influence of pressure:

$$\rho_{\text{Fluid}} = \rho_{\text{meas}} + \Delta\rho$$

Here,  $\rho_{\text{Fluid}}$  is the actual density at process pressure and  $\rho_{\text{meas}}$  is the density measured by the density sensor.

- ▶ Order option: Calibration to desired pressure (1 to 20 bar (abs)).

#### Repeatability

- Density:  $\pm 0.1 \text{ kg/m}^3$
- Temperature:  $\pm 0.05 \text{ }^\circ\text{C}$

#### Temperature conditions

Permitted medium temperature -40 to +60  $^\circ\text{C}$

Permitted ambient temperature -40 to +60  $^\circ\text{C}$

Permitted storage temperature -40 to +60  $^\circ\text{C}$

#### Area of application

Permitted measured density value 0 to 1600  $\text{kg/m}^3$

Permitted viscosity range 0.3 to 5 mPa s  
(Optionally 0.3 to 50 mPa s)

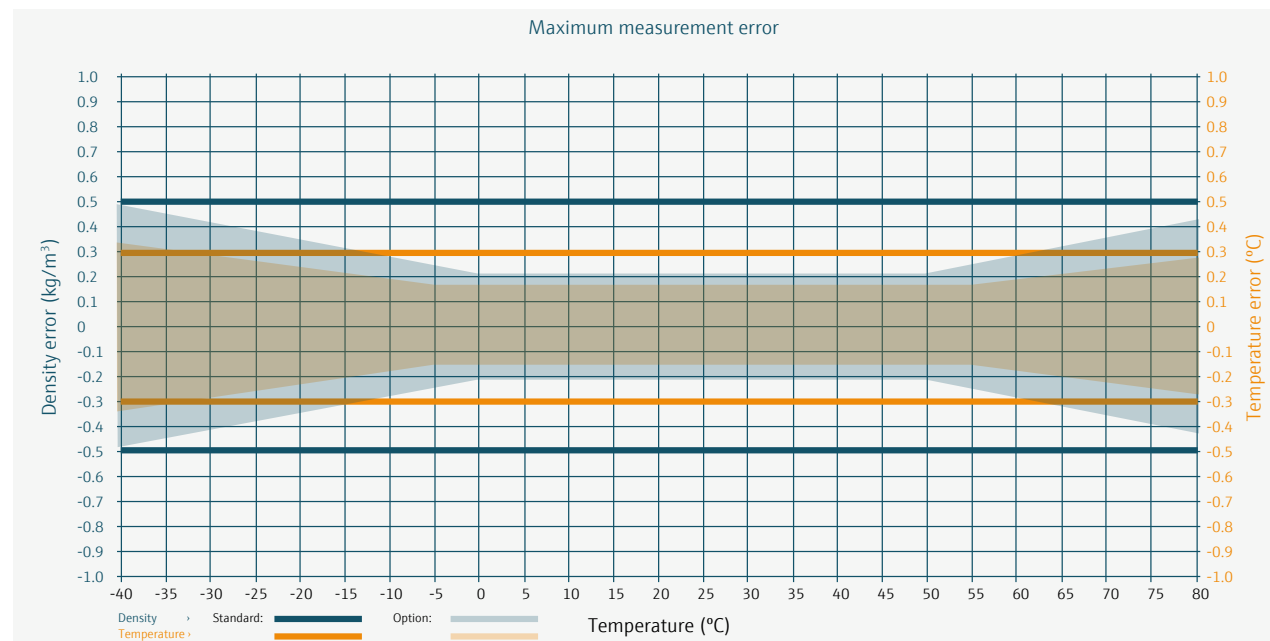





<b>Permitted medium pressure</b>	0 to 20 bar (abs) Burst pressure 80 bar (abs)
<b>Permitted particle size</b>	Max. 30 µm
<b>Permitted flow range</b>	0 to 10 l/h 0 to 1 l/h for gases
<b>Vibrations</b>	Vibrations (<20 kHz) have no influence on the measuring accuracy due to the high working frequency of the microchannel.
<b>Inlet and outlet runs</b>	Inlet and outlet runs have no influence on the measuring accuracy.
	<b>NOTICE</b>
	Permitted means that the measuring accuracy of the sensor is within the given specifications.
<b>Flow/pressure loss conditions</b>	<b>NOTICE</b>
	To ensure proper operation, the flow rate (Q) must not exceed 10 l/h. For gas measurements, the upper limit is 1 l/h.
<b>Units</b>	[K <sub>v</sub> ]= m <sup>3</sup> /h, [Q]=l/h, [Δp]=bar, [ρ]=kg/m <sup>3</sup> , [η]= mPa s

### Flow/pressure loss conditions

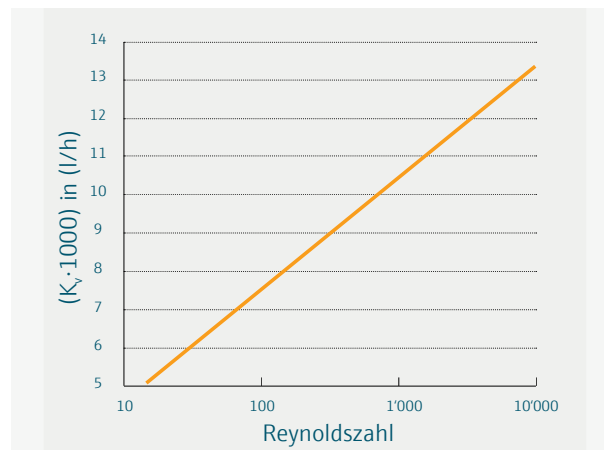

Flow factor versus Reynolds number ( $K_v (Re) = [1.28 \ln (Re) + 1.60] \pm 10\%$ )

**Determining the flow factor (K<sub>v</sub> · 1000 l/m<sup>3</sup>)**  
The flow factor can be read by means of the Reynolds number (Re) via the figure Flow / pressure loss conditions.

**Determination of Re via Q, ρ and η**  
$$Re \cong \frac{Q \cdot \rho}{2 \cdot \eta}$$

**Determination of Q via Δp**  
$$Q = K_v \cdot 1000 \text{ l/m}^3 \sqrt{\frac{\Delta p}{1 \text{ bar}} \cdot \frac{1000 \text{ kg/m}^3}{\rho}}$$

**Determination of Δp via Q**  
$$\Delta p = \left( \frac{Q}{K_v \cdot 1000 \text{ l/m}^3} \right)^2 \cdot \frac{\rho}{1000}$$

<b>Calculation</b>	If one of the needed factors such as Q is not available, several iteration steps are needed.
<b>Response time</b>	<ul style="list-style-type: none"> <li>The density is recorded with a measuring rate of at least 30 Hz. As a result of internal processing and filtering, the maximum group delay is 1 s.</li> <li>The temperature is recorded with a measuring rate of 2 Hz. As a result of internal processing and filtering, the maximum group delay is 2.5 s.</li> </ul>

### Ambient conditions

<b>Climate class</b>	In accordance with: <ul style="list-style-type: none"> <li>IEC/EN 60068-2-1</li> <li>IEC/EN 60068-2-2</li> <li>IEC/EN 60068-2-30</li> </ul>
<b>Electromagnetic compatibility</b>	EMC 2014/30/EU (EN 61326-1)
<b>Vibration and shock resistance</b>	In accordance with: <ul style="list-style-type: none"> <li>IEC/EN 60068-2-6</li> <li>IEC/EN 60068-2-27</li> <li>IEC/EN 60068-2-64</li> </ul>
<b>Protection class</b>	IP54 (IEC 60529)



### Materials

#### Housing

- Stainless steel:
  - 1.4404 (316L)
  - 1.4542 (AISI/SUS 630)

#### Wetted parts

- BOROFLOAT® 33 glass
- Silicon
- Epoxy resin
- Stainless steel:
  - 1.4542 (AISI/SUS 630)
- Alternative to stainless steel:
  - 2.4605 (Alloy 59)

### Dimensions

#### Housing

30 x 66 x 15 mm<sup>3</sup> (without cable, cable gland and connection for protective ground)

#### Weight

<200 g

#### Dimensions of measurement channel

160 x 200 μm (500 nl)

### Fluid interface

#### Fluid interfaces

2 x M5 threaded holes at a 45° angle to the side and front surface

### Electrical interface

#### Cable design

Permanently installed cable. Connecting cable type KS-Li-9YD11Y 4xAWG 28, manufacturer: Kabel Sterner

#### Cable length

3 m (optionally up to 20 m)

#### Cable outer diameter

2.3 mm

#### Wire diameter

4 x AWG 28

### Level control

Digital communication lines and power supply in one common shielded cable

- Unidirectional, RS-485

#### NOTICE

For the variant DLO-M2\_ex

- ▶ Provide a 330 Ω termination resistor on the client side (see Page 6)

For the variant DLO-M2 (non-ex)

- ▶ For the integration in RS485-Modbus a bus termination according to specification "Modbus over serial line V1.02" has to be provided.

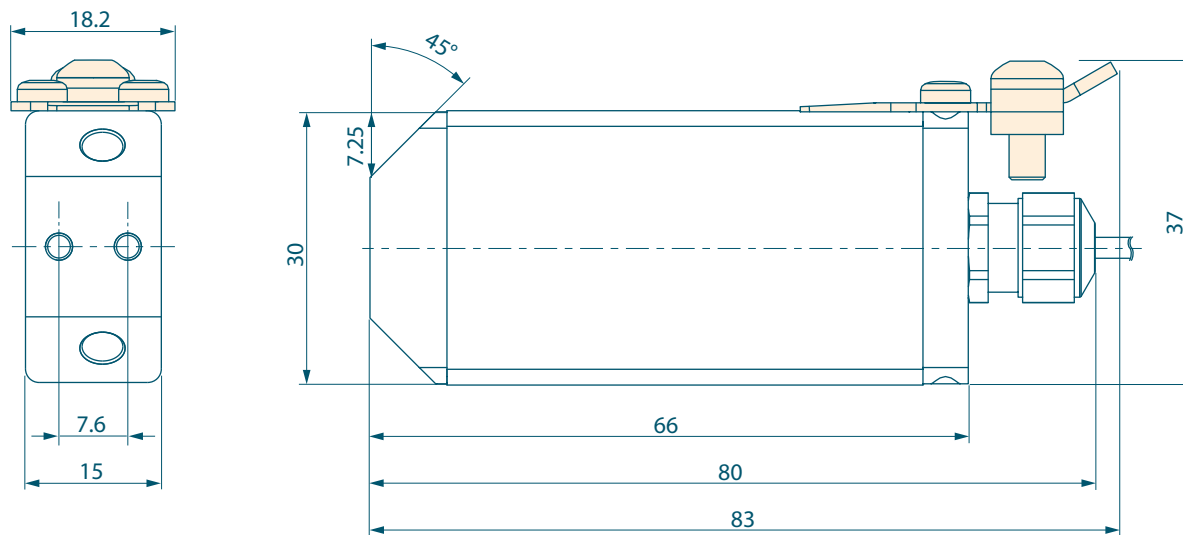

Design, dimensions in mm  
(orange parts valid for DLO-M2\_ex only)



<b>Energy supply</b>	Maximum current draw 26 mA, maximum power consumption 350 mW.  <b>NOTICE</b> The power supply unit must be safety tested (e.g. PELV, SELV). For the variant DLO-M2_ex ▶ Supply: 9.4 V to 13.3 V (typical: 12 V)
	For the variant DLO-M2 (non-ex)  ▶ Supply: 5 V to 13.3 V  <b>⚠ WARNING</b> For DLO-M2_ex, observe safety instructions DB-KU-100206-*. The asterisk (*) stands for the version. ▶ Zener barriers (supply and RS485)
<b>Dielectric strength</b>	Version DLO-M2_ex  The reference potential (GND) is connected to the housing and the ground connection (see product design). There is no galvanic isolation between the supply circuits, the communication interface and GND.

<b>Dielectric strength (continued)</b>	Version DLO-M2 (non-ex)  There is a capacitive coupling between the reference potential (GND) and the housing (ground). The dielectric strength is 50 V. There is no galvanic isolation between the supply circuits, the communication interface and GND.  The cable shield is connected to the sensor housing. The shield must be connected to the protective earth on the connection side according to the "Modbus over serial line V1.02" specification.									
	<b>Cable assignment</b> <table border="1"> <thead> <tr> <th>Wire color</th> <th>Assignment</th> </tr> </thead> <tbody> <tr> <td>yellow</td> <td>RS485 B, D1</td> </tr> <tr> <td>green</td> <td>RS485 A, D0</td> </tr> <tr> <td>brown</td> <td>GND (signal ground), common</td> </tr> <tr> <td>white</td> <td>V<sub>DD</sub> (supply voltage)</td> </tr> </tbody> </table>	Wire color	Assignment	yellow	RS485 B, D1	green	RS485 A, D0	brown	GND (signal ground), common	white
Wire color	Assignment									
yellow	RS485 B, D1									
green	RS485 A, D0									
brown	GND (signal ground), common									
white	V <sub>DD</sub> (supply voltage)									
	<b>NOTICE</b> The wire color code does not comply with the "Modbus over serial line V1.02" specifications.									

### Certificates and approvals

**CE marking** The density sensor meets the legal requirements of the EC directives. TrueDyne Sensors AG confirms the successful testing of the density sensor with the attachment of the CE mark.

### IECEX, ATEX



**WARNING**  
Applies to the DLO-M2\_ex version

Depending on the version, the product complies with the following directives:

		DLO-M2	DLO-M2_ex
<b>ATEX</b>	2014/34/U(L96/309)		✓
<b>LVD</b>	2014/35/EU(L96/357)	✓	✓
<b>EMC</b>	2014/30/EU(L96/79)	✓	✓
<b>RoHS</b>	2011/65EU(L174/88)	✓	✓

The following standards are complied with:

	DLO-M2	DLO-M2_ex
EN 61010-1: 2010	✓	✓
EN IEC 60079-0: 2019		✓
EN 60079-11: 2012		✓
EN 61326-1: 2013	✓	✓
EN 61326-2-3: 2013	✓	✓
EN 50581: 2012	✓	✓



## Legal restrictions

<b>Fields of industry</b>	For legal reasons, the sensor may not be used in the following industries in the USA: <ul style="list-style-type: none"> <li>▪ Military (any applications in the military field whatsoever, including airplanes, vehicles or military structures. This does not include fuel delivery and fuel dispensing when refuelling on the ground)</li> <li>▪ Aerospace (applications in flying objects of any kind. Excluded from this is fuel delivery and fuel dispensing when refuelling on the ground)</li> <li>▪ Fuel cells (use in stationary or mobile fuel cells)</li> <li>▪ Medical devices (objects or substances used for medical purposes for human beings - the pharmaceutical industry is not affected)</li> </ul>
---------------------------	---

## Modbus

Default settings:

<b>Baud rate</b>	19200 BAUD
<b>Data bits</b>	8
<b>Parity</b>	Even
<b>Byte order</b>	1-0-3-2
<b>Stop bits</b>	1 bit

Modbus

<b>Modbus address</b>	247
<b>FlowControl</b>	None (0)
<b>Transmission type</b>	Modbus RTU (protocol)
<b>Temperature unit</b>	°C
<b>Pressure unit</b>	bar abs
<b>Density unit</b>	kg/m <sup>3</sup>
<b>*Dynamic viscosity unit</b>	mPa s
<b>*Kinematic viscosity unit</b>	mm <sup>2</sup> /s

### NOTICE

- ▶ **\*Optional: see product viscosity sensor VLO-M2 | VLO-M2\_ex**

The following Modbus RTU functions are supported:

Code	Name	Description
0x01	Read Coils	Read one or more coils
0x03	Read Holding Registers	Read a consecutive holding register block
0x04	Read Input Registers	Read one or more successive registers
0x05	Write Single Coil	Write one coil
0x06	Write Single Register	Write one single register

0x0F	Write Multiple Coils	Write multiple successive coils
0x10	Write Multiple Registers	Write multiple successive registers

### NOTICE

The following Modbus RTU functions are not supported

- ▶ 0x02 Read Discrete Inputs
- ▶ 0x07 Read Exception Status
- ▶ 0x08 Diagnostics
- ▶ 0x0B Get Comm Event Counter
- ▶ 0x0C Get Comm Event Log

When addressing the devices, it is essential to ensure that there are not two devices with the same address. In such a case an abnormal behaviour of the whole serial bus can occur, because the master is then no longer able to communicate with all existing slaves on the bus.

### Compared to the "Modbus over serial line V1.02" protocol, the following differences exist:

- ▶ 3.6 Cables - The cable strands are not twisted together.
- ▶ 3.7 Visual Diagnostics - There is no LED display on the sensor.
- ▶ "Line Polarisation" is not necessary for the sensor and is not provided.

**Min. 32 sensors (non-ex) are supported in the bus system. supported.**



## Modbus Register Informationen

### Info

Name	Address	Data type	Selection/input	Operator	Maintenance
<b>Memory Version</b>	100	UINT16		r	r
<b>Serial Number</b>	101 ...107	STRING14		r	r
<b>Software Version</b>	108	UINT16		r	r
<b>Software Build</b>	109	UINT16		r	r
<b>Pin</b>	110 ...117	STRING16		r	r
<b>Device Identity</b>	1	UINT16		r	r
<b>Device Name</b>	7262 ...7269	STRING16		r	r
<b>Firmware Version</b>	7276 ...7279	STRING8		r	r
<b>Access status tooling</b>	2177	UINT16	0: Operator 1: Maintenance 2: Service (only TrueDyne)	r	r

## Config

### Modbus

Name	Address	Data type	Selection/input	Operator	Maintenance
<b>Modbus address</b>	4909	UINT16	1 ...247	r	r/w
<b>Baud rate</b>	4911	UINT16	3: 9600 4: 19200 5: 38400 6: 57600 7: 115200	r	r/w
<b>Parity</b>	4913	UINT16	0: None / 2 stop bits 1: Even / 1 stop bit 2: Odd / 1 stop bit 3: None / 1 stop bit	r	r/w
<b>Byte order</b>	4914	UINT16	0: 0-1-2-3 1: 3-2-1-0 2: 2-3-0-1 3: 1-0-3-2	r	r/w

*r = read / w = write / Modbus registers refer to the start value 0*



Device

Name	Address	Data type	Selection/input	Operator	Maintenance
Restart Device	6816	UINT16	0: False 1: True	r/w	r/w
Device Tag	4900 ...4907	STRING16	Freely selectable	r	r/w
Enter Access code	2176	UINT16	0...65535 For maintenance 8646	r/w	r/w
FB User Level	2179	UINT16	0: Operator 1: Maintenance 2: Service (TrueDyne only)	r	r/w
Reset Device	201	UINT16	0: Off 1: Reset to SW-defaults	r	r/w

Sensor

Name	Address	Data type	Selection/input	Operator	Maintenance
Pressure compensation	5183	UINT16	0: Off 1: Fixed Value 2: External Value	r	r/w
Fixed Pressure	5184 ...5185	FLOAT32		r	r/w
External Pressure	2439 ...2440	FLOAT32		r	r/w

**NOTICE**

- ▶ For pressure compensation, the pressure can be written as a fixed parameter. By default, the pressure value is 1.01325 bar abs.
- ▶ The density sensor does not include a pressure sensor. However, it is possible to write the externally measured pressure into the density sensor (see special documentation for gas measurement).
- ▶ For frequent writing of the pressure value, please set the "Pressure compensation" to "External value" and use the "External pressure" parameter. This value is not stored in the EEPROM. Frequent writing of the "Fixed pressure" parameter can lead to a memory violation in the EEPROM.

Pressure unit	2129	UINT16	0: bar abs 1: bar gauge 2: psi abs 3: psi gauge 4: kPa abs 5: kPa gauge	r	r/w
Density unit	2106	UINT16	0: g/cm <sup>3</sup> 1: g/cc 2: kg/l 3: kg/m <sup>3</sup> 4: lb/ft <sup>3</sup> 5: lb/gal 6: Specific gravity	r	r/w

**NOTICE**

- ▶ Specific gravity (SG) is calculated with the current temperature (T) in relation to water.

$$SG = \frac{\rho_{\text{medium}}(T)}{\rho_{\text{water}}(T)}$$

r = read / w = write / Modbus registers refer to the start value 0



Temperature unit	2108	UINT16	0: °C 1: K 2: °F 3: °R	r	r/w
<sup>2</sup> Dynamic viscosity unit	2110	UINT16	0: cP 1: P 2: Pa s 3: mPa s	r	r/w
<sup>2</sup> Kinematic viscosity unit	2111	UINT16	0: m <sup>2</sup> /s 1: mm <sup>2</sup> /s 2: cSt 3: St	r	r/w
Density single point	205 ...206	FLOAT32		r	r/w
Density offset	5528 ...5529	FLOAT32		r	r/w
Reset density offset	207	UINT16	0: Off 1: Reset	r	r/w
<sup>2</sup> Viscosity single point	208 ...209	FLOAT32		r	r/w
<sup>2</sup> Viscosity offset	5530 ...5531	FLOAT32		r	r/w
<sup>2</sup> Reset viscosity offset	210	UINT16	0: Off 1: Reset	r	r/w
<sup>1</sup> Single point adjustment	2510	UINT16	0: Off 1: Water	-	r/w

## MinMaxValues

Name	Address	Data type	Selection/input	Operator	Maintenance
LowerBoundDensityRange	2600 ...2603	FLOAT32		r	r
UpperBoundDensityRange	2604 ...2605	FLOAT32		r	r
LowerBoundTemperatureRange	2608 ...2609	FLOAT32		r	r
UpperBoundTemperatureRange	2612	FLOAT32		r	r
LowerBoundPressureRange	2616 ...2617	FLOAT32		r	r
UpperBoundPressureRange	2620 ...2621	FLOAT32		r	r
LowerBoundConcentrationRange	2624 ...2625	FLOAT32		r	r/w
UpperBoundConcentrationRange	2628 ...2629	FLOAT32		r	r/w
<sup>2</sup> LowerBoundViscoRange	2632 ...2633	FLOAT32		r	r
<sup>2</sup> UpperBoundViscoRange	2636 ...2637	FLOAT32		r	r

## NOTICE

- ▶ <sup>1</sup>For balancing with gases: see special documentation for gases.
- ▶ <sup>2</sup>Optional: see product viscosity sensor VLO-M2 | VLO-M2\_ex

*r = read / w = write / Modbus registers refer to the start value 0*



Concentration

Name	Address	Data type	Selection/input	Operator	Maintenance
<b>LiquidType</b> In addition to the LiquidType there is the GasType (see special documentation for gases).	26491	UINT16	0: Off 1: User coeffs 2: Fructose in water 3: Glucose in water 4: Sucrose in water 5: Invert sugar in water 6: Hydrogen peroxide in water 7: Ethanol in water (OIML) 8: Methanol in water 9: Ethyleneglycol in water 10: HFCS42 11: HFCS55 12: HFCS90 13: Sodium chloride in water 14: Total dissolved solids in water 15: Butane in Propane	r	r/w
<b>Custom Mixture Text</b>	2584 ...2588	STRING10	An additional mixture can be parameterised by TrueDyne. The designation of the mixture can be stored here.	r	r

Concentration unit	2438	UINT16	0: SGU 1: °Brix 2: °Balling 3: Proof/Vol 4: %Vol 5: %Vol@20°C 6: °Plato 7: mol/l 8: %ABV@20°C 9: %mass 10: mg/l 11: %StdVol 12: User conc. 13: %mol	r	r/w

**NOTICE**

► Desired liquid and gas types can be specified when ordering.





## Process Variable

Name	Address	Data type	Selection/input	Operator	Maintenance
Density	2012 ...2013	FLOAT32		r	r
<sup>5,6</sup> Density compensated	2030 ...2031	FLOAT32		r	r
Temperature	2016 ...2017	FLOAT32		r	r
Pressure	2088 ...2089	FLOAT32		r	r
<sup>5,6</sup> Dynamic viscosity	2018 ...2019	FLOAT32		r	r
<sup>5,6</sup> Kinematic viscosity	2082 ...2083	FLOAT32		r	r
<sup>6</sup> Concentration	2597 ...2598	FLOAT32		r	r

## Status

Name	Address	Data type	Selection/input	Operator	Maintenance
<sup>7</sup> DensityInRange	12	UINT16	0: False 1: True	r	r
<sup>8</sup> SensorOK	13	UINT16	0: False 1: True	r	r
<sup>7</sup> TemperatureInRange	14	UINT16	0: False 1: True	r	r
<sup>7</sup> PressureInRange	15	UINT16	0: False 1: True	r	r
<sup>7</sup> ConcentrationInRange	16	UINT16	0: False 1: True	r	r
<sup>5,7,8</sup> ViscosityInRange	17	UINT16	0: False 1: True	r	r

### NOTICE

- ▶ <sup>5</sup>Optional: see product viscosity sensor VLO-M2 | VLO-M2\_ex
- ▶ <sup>6</sup>The desired software option must be specified when ordering.
- ▶ <sup>7</sup>Testing is performed according to the "Lower" and "Upper" bounds defined in the parameters (see p. 16).
- ▶ <sup>8</sup>The status of the sensor is continuously checked internally. In normal operation, SensorOK = 1 is output. If the properties of the sensor are outside a defined range, e.g. in the event of faults due to air bubbles in the sensor, this parameter is set to 0.

*r = read / w = write / Modbus registers refer to the start value 0*



## Download area

On our website [www.truedyne.com](http://www.truedyne.com) you will find this document and other useful documents in our download area.

### Documents and files

#### Product information

- Data sheet
- Safety notes
- STEP file
- Special documentation density sensor DLO-M2 | DLO-M2\_ex for gases
- Calibration certificate (optional)

#### Declarations of conformity

- CE marking EU declaration of conformity
- RoHS III EU declaration of conformity

#### Training courses

- Basics of density measurement training



[https://www.truedyne.com/dlo-m2\\_ex\\_download\\_en](https://www.truedyne.com/dlo-m2_ex_download_en)



[https://www.truedyne.com/dlo-m2\\_download\\_en](https://www.truedyne.com/dlo-m2_download_en)



## Website

Are you looking for more innovative sensors for density and viscosity? Visit our website [www.truedyne.com](http://www.truedyne.com) and learn more about our current product portfolio.

### Product portfolio

#### Sensors for measuring fluids

For example:

- DLO-M2 density sensor
- VLO-M2 viscosity and density sensor
- FLT-M1 flow sensor

#### Sensors for measuring gases

- DGF-I1 density sensor
- Nanomass density sensor



- [www.truedyne.com](http://www.truedyne.com)

