

# Flow sensor type 212 for liquid media with display

Flow range  
0.5 ... 150 l/min

Nominal diameters  
DN 6 / 8 / 10 / 15 / 20 / 25

Temperature measurement  
-20 ... +85 °C



The flow sensor type 212 is based on the Vortex trail principle. This flow sensor convinces due to the additional digital indicating device which shows the flow rate and the media temperature. The type 212 is available with and without temperature measurement.

With no moving parts the flow sensor is not sensitive to debris, has marginal pressure loss and high accuracy.

- Flow measuring with immediate display of flow measuring range and medium temperature
- Temperature non-sensitive flow measuring principle
- Excellent media resistance (measuring element not in contact with the media)
- CE conformity
- Wide application temperature range
- Marginal loss of pressure
- Measuring element not sensitive to debris
- Direct temperature measurement in the medium
- Drinking water approval

## Technical overview

### Flow measurement

Measuring principle	Vortex	Piezoelectric sensor element
Measuring range		0.5 ... 150 l/min
Nominal diameters		DN 6 / 8 / 10 / 15 / 20 / 25
Accuracy (via temperature) at < 50% fs (water)		< 1% fs
Accuracy (via temperature) at > 50% fs (water)		< 2% measuring value
Response time		Signal delay < 2 s
		Response time < 500 ms
		Display update rate < 500 ms

### Temperature measurement (≥ 8 DN)

4 ... 14.5 mA	Measuring range	-20 ... +85 °C
	Accuracy	± 1 K
	Calculation temperature	$T(°C) = I[mA] - 6$ 0.1

### Operating conditions

Medium	Water	Other medium on request
Temperature	Media	< +85 °C
	Ambient	-20 ... +50 °C
	Storage	-30 ... +80 °C
	(for lifetime)	12 bar at +40 °C
Max. pressure and medium temperature	(for lifetime)	6 bar at +100 °C
	(max. test pressure)	18 bar at +40 °C
Cavitation	The following equation is valid to prevent cavitation: $P_{abs\ outer} / P_{difference} > 5.5$	

### Materials in contact with medium

Sensor paddle	ETFE
Case with damming body	PA6T/6I (40% GF)
Sealing material	EPDM (perox.)
	FPM

### Electrical overview

Power supply	10 ... 30 VDC	
Output flow (Q)	4 ... 20 mA	
Output temperature (T)	4 ... 14.5 mA	
Electrical connection and IP protection	M12x1 (IP 65)	
Load	Flow	< $(U_{IN} - 10 V) / 20 mA$
	Temperature	< $(U_{IN} - 10 V) / 14.5 mA$
Current consumption max.	< 50 mA	
Electrical reliability	Short circuit, reverse voltage and external voltage protected within the admissible supply voltage.	

### Weight

DN 6 / 8	~ 90 g
DN 10	~ 105 g
DN 15	~ 115 g
DN 20	~ 135 g
DN 25	~ 150 g

### Test / Admissions

Electromagnetic compatibility	CE conformity acc. EN 61326-2-3
Shock acc. IEC 68-2-27	15 g, 6 ms, half sine wave, all 6 directions
Vibration acc. IEC 68-2-6	15 g, 61 ... 2000 Hz, 10 ... 61 Hz with amplitude ± 1 mm, 1 Octave/min. all 3 directions, 20 constant load
MTTF	577 years
Drinking water approval	WRAS
	Plastic parts with KTW and W270 approval

### Packaging

Single packaging	
Multiple packaging	

## Minimum life span on high flow rate and high temperature

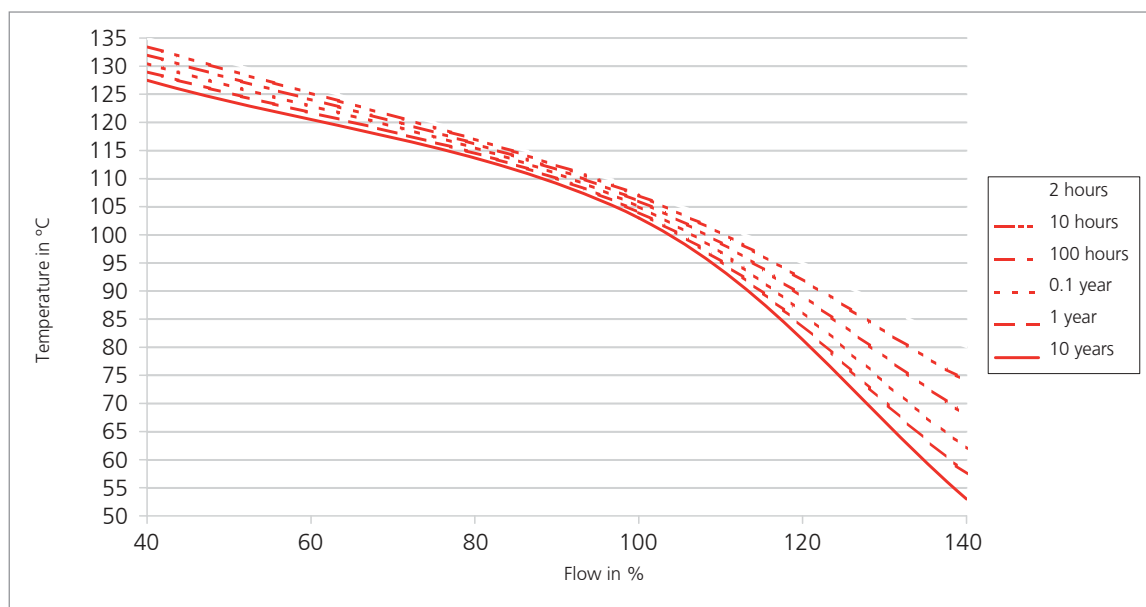

## Nominal diameters dependent variables

Nominal diameters	Tube connection	Measuring range	Flow range	K <sub>i</sub>	Pressure drop <small>1), 2)</small>
DN 6	K	0.5 ... 10 l/min	0.074 ... 1.474 m/s	0.625	240 * Q <sup>2</sup>
	G				
DN 8	K	0.9 ... 15 l/min	0.133 ... 2.210 m/s	0.938	85.00 * Q <sup>2</sup>
	G				
	N				
DN 10	K	1.8 ... 32 l/min	0.265 ... 4.716 m/s	2.000	22.50 * Q <sup>2</sup>
	G				
	N				
DN 10	K	2.0 ... 40 l/min	0.295 ... 5.895 m/s	2.500	22.50 * Q <sup>2</sup>
	G				
	N				
DN 15	K	3.5 ... 50 l/min	0.290 ... 4.145 m/s	3.125	6.70 * Q <sup>2</sup>
	G				
	N				
DN 20	K	5.0 ... 85 l/min	0.265 ... 4.509 m/s	5.313	2.50 * Q <sup>2</sup>
	G				
	N				
DN 25	K	9.0 ... 150 l/min	0.283 ... 4.709 m/s	9.375	0.92 * Q <sup>2</sup>
	G				

### Characteristic line formula

current output  
 $Q_v = K_i * (I_{OUT} - 4 \text{ mA})$

### Legend

Q <sub>v</sub>	Volume flow rate	[l/min]
K <sub>i</sub>	Coefficient current output	[(l/min) / mA]
I <sub>OUT</sub>	Current	[mA]

Order code selection table		1	2	3	4	5	6	7	8	9
		212.	X	X	X	X	X	X	X	X
Version	Flow	9			4					
	Flow and temperature	8			5					
Nominal diameters and flow rate	DN 6 0.5 ... 10 l/min. (with temperature on request)	9	0	6	4					K,G
	DN 8 0.9 ... 15 l/min.		0	8						
	DN 10 1.8 ... 32 l/min.		1	0						
	DN 10 2.0 ... 40 l/min.		1	1						
	DN 15 3.5 ... 50 l/min.		1	5						
	DN 20 5.0 ... 85 l/min.		2	0						
	DN 25 9.0 ... 150 l/min.		2	5						K,G
Output / power supply	Q: 4 ... 20 mA 10 ... 30 VDC (without temperature)	9			4					
	Q: 4 ... 20 mA T: 4 ... 14.5 mA 10 ... 30 VDC	8			5					
Display	2 lines static	8			5	0				
	1 line alternate (2s)	8			5	1				
	1 line static	9			4	2				
Unit temperature display	none (at Version „Flow“)	9			4		0			
	Degrees Celsius (°C)	8			5		C			
	Degrees Fahrenheit (°F)	8			5		F			
Unit flow display	Liter per minute (l/min)								M	
	Liter per second (l/s)								S	
Sealing material	EPDM									1
	FPM									2
Tube connection	Plastic PA6T / 6I									
	connection copper tube (max. DN 20)									N
	outside thread K (see dimension diagram)									K
	outside thread G (see dimension diagram)									G

## Accessories

Accessories supplied loose

	Order number
Connection kit <sup>3)</sup> DN 8, 10 with copper tube	113775
Connection kit <sup>3)</sup> DN 8, 10 with adapter Rp 3/8 (inside)	113776
Connection kit <sup>3)</sup> DN 15 with copper tube	113777
Connection kit <sup>3)</sup> DN 15 with adapter Rp 1/2 (inside)	113778
Connection kit <sup>3)</sup> DN 20 with copper tube	113779
Connection kit <sup>3)</sup> DN 20 with adapter Rp 3/4 (inside)	113780
Straight-wire box for connector M12x1 with cable	5-pole 200 cm (with temperature output) 114564
Corner-wire box for connector M12x1 with cable	5-pole 200 cm (with temperature output) 114563
Straight-wire box for connector M12x1 screwing terminal	5-pole 115024
Clip for DN 8,10	112116
Clip for DN 15	110941
Clip for DN 20	112122
O-Ring for DN 8, 10	EPDM ø 13.95 x 2.62 Copper tube and adapter 112124
O-Ring for DN 15	EPDM ø 17.86 x 2.62 Copper tube and adapter 112265
O-Ring for DN 20	EPDM ø 21.89 x 2.62 Copper tube and adapter 112723
O-Ring for DN 25	EPDM ø 31 x 3 (as a replacement, already assembled) 112792
Connection copper tube for DN 8, 10	L=150 mm 112121
Connection copper tube for DN 15	L=150 mm 112211
Connection copper tube for DN 20	L=150 mm 112306
Adapter (inside thread) for DN 8, 10	Rp 3/8 Stainless steel 1.4305/AISI 303 112655
Adapter (inside thread) for DN 15	Rp 1/2 Stainless steel 1.4305/AISI 303 112660
Adapter (inside thread) for DN 20	Rp 3/4 Stainless steel 1.4305/AISI 303 112661

<sup>1)</sup> incl. 3xDi inlet and outlet side

<sup>2)</sup> Pv in Pa; Q in l/min

<sup>3)</sup> Connection set includes: 2x Clip, 2x Copper tubes or Adapter and 2x O-Ring

Dimension diagram DN 6, 8, 10, 15, 20, 25

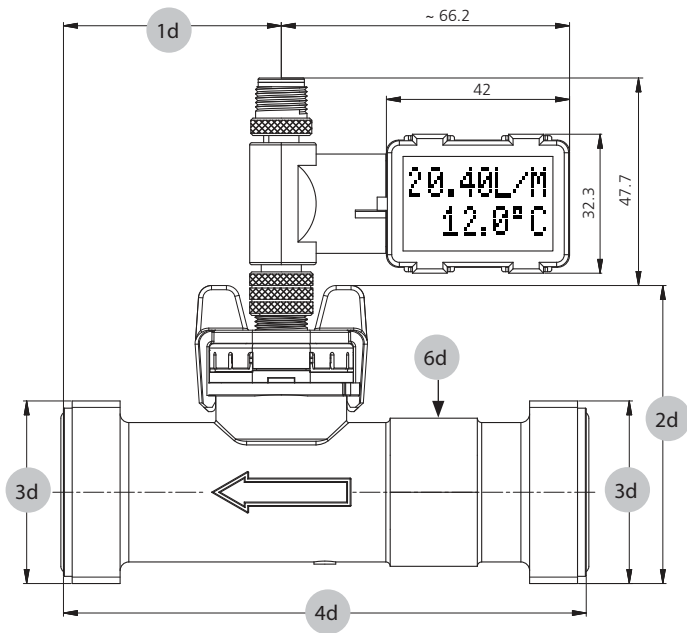

		1d	2d	3d	4d	5d	6d
DN6	K	43.7	53.0	G ½	77	11.5	↪ 12
DN6	G	48.2	55.7	G ¾	86	11.5	↪ 12
DN8	K	43.7	53.0	G ½	77	11.5	↪ 12
DN8	G	48.2	55.7	G ¾	86	11.5	↪ 12
DN10	K	35.0	51.3	G ½	81	11.5	↪ 19
DN10	G	39.5	54.1	G ¾	90	11.5	↪ 19
DN15	K	36.6	56.1	G ¾	87	16	↪ 22
DN15	G	41.6	59.5	G 1	97	16	↪ 22
DN20	K	36.6	61.5	G 1	105	20	↪ 27
DN20	G	42.6	65.8	G 1¼	117	20	↪ 27
DN25	K	50.0	68.3	G 1¼	120	26	↪ 34
DN25	G	56.0	71.3	G 1½	132	26	↪ 34

Dimension diagram DN 8, 10, 15, 20

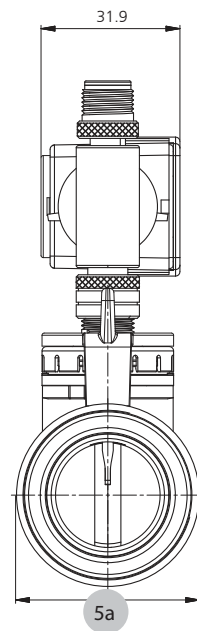
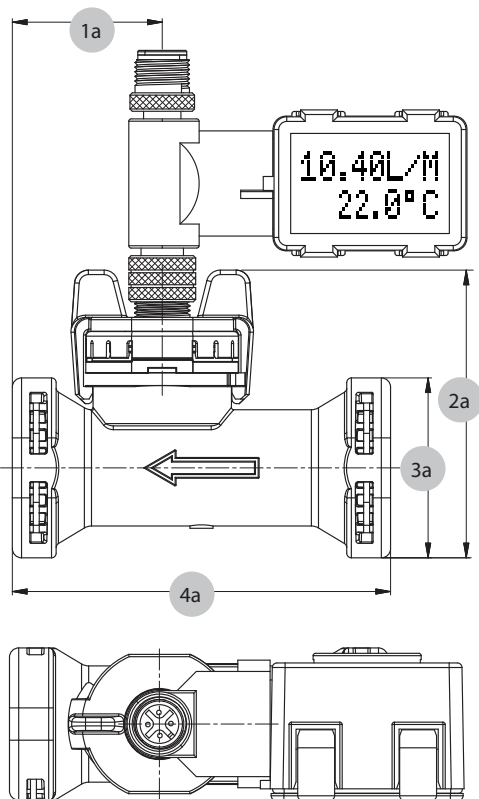

	1a	2a	3a	4a	5a
DN8	29.5	59.0	32.9	72	28.9
DN10	32.5	57.3	32.9	77	28.9
DN15	32.5	62.4	39.0	82	33.0
DN20	39.3	66.3	43.0	105	37.4

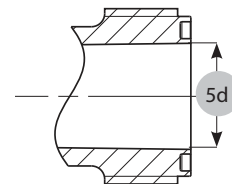

## Admissible locking torque



	DN6/8/10 G ½	DN6/8/10 G ¾	DN15 G ¾	DN15 G1	DN20 G1	DN20 G1 ¼	DN25 G1 ¼	DN25 G1 ½
$M_{min}$ [Nm]	1	1	1	2	2	2.5	2.5	2.5
$M_{max}$ [Nm]	12	12	12	12	12	15	15	15

## Accessories DN 8, 10, 15, 20

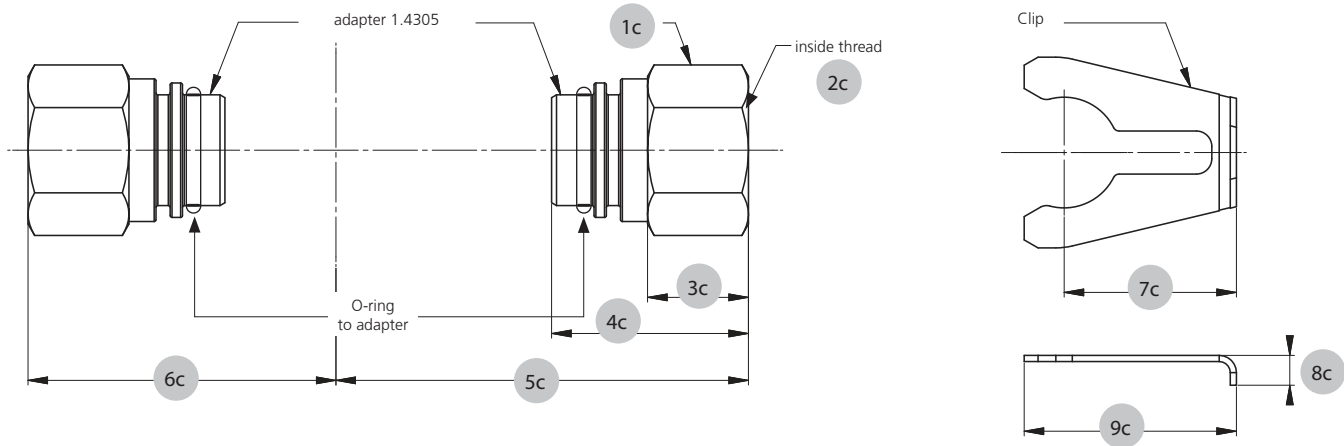

	1c	2c	3c	4c	5c	6c	7c	8c	9c
DN8	22	Rp ¾ DIN 2999 Länge min. 9	14.0	29	57.65	44.65	24.5	7.3	30.8
DN10	22	Rp ¾ DIN 2999 Länge min. 9	14.0	29	59.65	47.55	24.5	7.3	30.8
DN15	24	Rp ½ DIN 2999 Länge min. 11.5	16.4	32	67.05	50.05	28.0	7.6	34.5
DN20	30	Rp ¾ DIN 2999 Länge min. 13	18.5	38	82.25	58.85	28.0	8.7	34.5

## Geometry of customers connection tube DN 8, 10, 15, 20

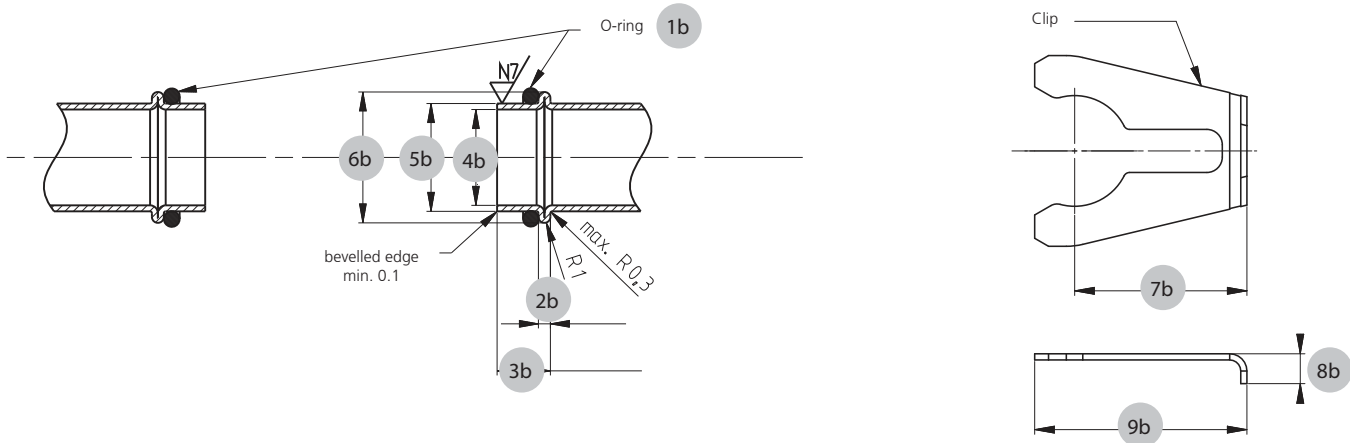

	1b	2b	3b	4b	5b	6b	7b	8b	9b
DN8	∅ 13.95x2.62	2 ± 0.2	8.9 ± 0.2	∅ 13 ± 0.2	∅ 15.00 ± 0.08	∅ 18.88 ± 0.1	24.5	7.3	30.8
DN10	∅ 13.95x2.62	2 ± 0.2	8.9 ± 0.2	∅ 13 ± 0.2	∅ 15.00 ± 0.08	∅ 18.88 ± 0.1	24.5	7.3	30.8
DN15	∅ 17.86x2.62	2 ± 0.2	8.9 ± 0.3	∅ 16 ± 0.2	∅ 18.00 <sup>+0.08</sup> <sub>-0.06</sub>	∅ 21.85 ± 0.1	28.0	7.6	34.5
DN20	∅ 21.89x2.62	2 ± 0.2	12.9 ± 0.3	∅ 20 ± 0.2	∅ 22.00 <sup>+0.08</sup> <sub>-0.06</sub>	∅ 25.85 ± 0.1	28.0	8.7	34.5

## Tube mounting instructions

Consider the following to ensure the correct function of the sensor.

- Only diameter changes from large to small are allowed.
- Avoid repeated elbows in the same level at entryside

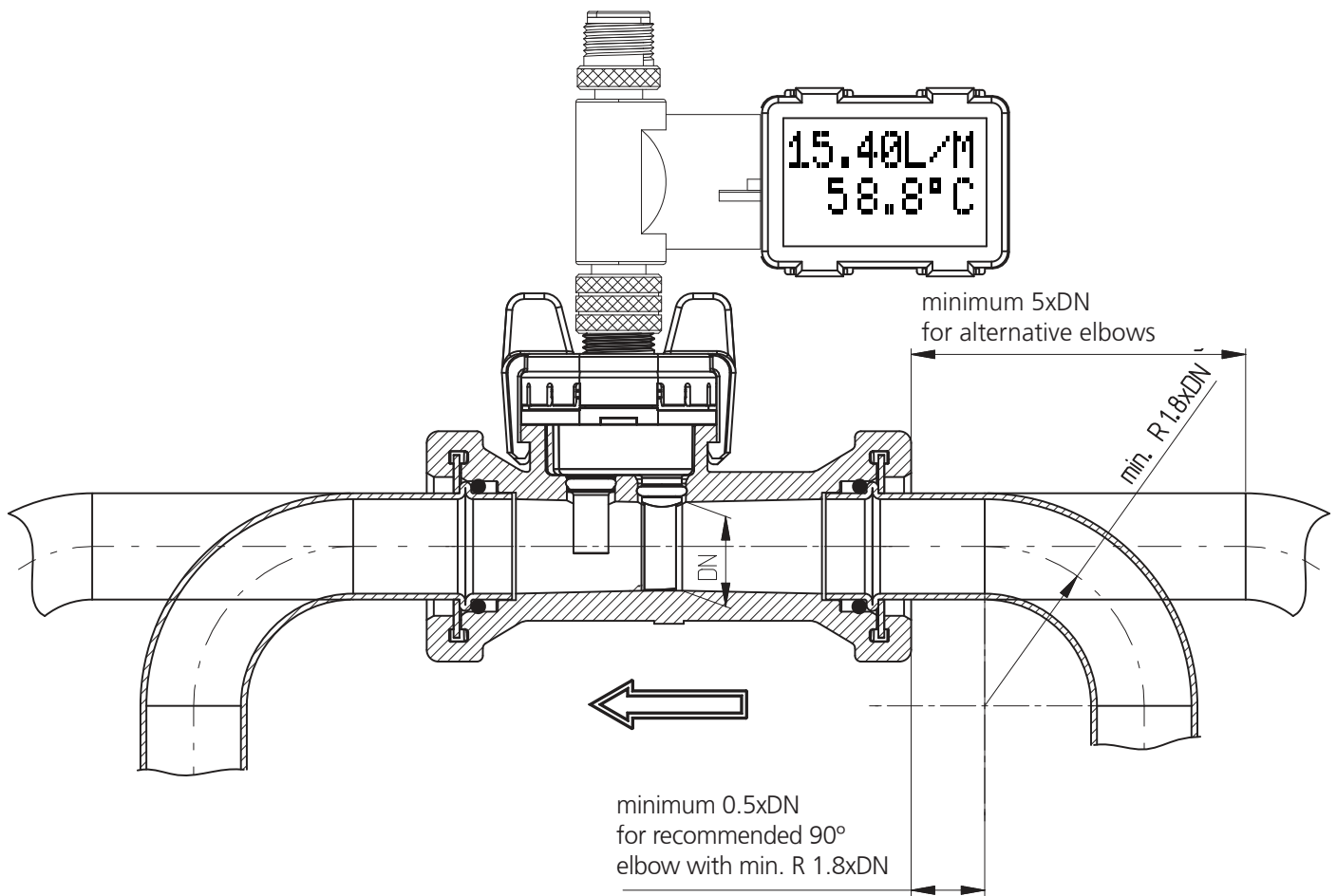

## Electrical connection

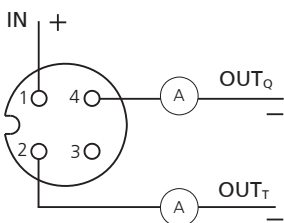

Pin 3 - not connected

Connect pin 1 and pin 4 to ensure the power supply of the internal electronic.