

Rosemount™ 228 Toroidal Conductivity Sensor



A Versatile Conductivity Sensor for Solving Diverse Application Challenges

Rosemount 228 toroidal conductivity sensors reliably measure conductivity in highly conductive electrolyte solutions up to 2 S/cm (2,000,000,000 μ S/cm). These sensors work in dirty and corrosive applications where metal electrode sensors would otherwise fail. A robust sensor design makes the Rosemount 228 ideal for measuring concentrations of acid, base, and salt solutions.



High Performance and Reliability

- Meet challenging application requirements with a selection of chemical resistant body options including PEEK and Tefzel
- High vibration tolerance with reinforced internal metal frame design
- High temperature option for process temperatures up to 392 °F (200 °C) and suitable for use under high pressure up to 295 psig (2135 kPa [abs])



Meet Your Process Mounting Needs

- Suitable for insertion and submersion type applications
- Versatile mounting options featuring either a 3/4 in. MNPT or 5/8 in. 11 UNC process connection
- Eliminate the need to shut down your process when removing sensors from piping and tanks by using an optional retraction assembly kit

Contents

Ordering Information..... 3

Specifications..... 4

Dimensional Drawings..... 6

Accessories..... 9

Ordering Information



Rosemount 228 Toroidal Conductivity Sensors are molded of chemically resistant glass-filled PEEK or Tefzel and are ideal for measuring concentrations of acid, base, and salt solutions. The sensors include an integral PT-100 RTD for temperature compensation and an integral cable length of 20 ft. The Rosemount 228 can be used with a variety of insertion mounting adapters to meet your installation requirements (see "Accessories").

Rosemount 228 Toroidal Conductivity Sensor

Table 1 -Rosemount 228 Toroidal Conductivity Sensor Ordering Information

Model	Sensor Type
228	Toroidal Conductivity Sensor
Materials of Construction	
02	Glass-filled PEEK (standard temperature)
03	Glass-filled PEEK (high temperature)
04	Glass filled Tefzel ¹
09	Unfilled Tefzel ²
Process Connection	
20	5/8 in. 11 UNC ³
21	3/4 in. MNPT ⁴
Cable Type⁵	
54	Unshielded cable ⁶
56	EMI/RFI shielded cable ⁷
Cable Length	
61	20 ft (6.1 m)
62	18 in. (457 mm) ⁸
Typical model number: 228-03-21-51-61	

(1) Not available with options -50-62 and -54-62

(2) Not available with option -54-62

(3) This option requires a mounting adapter. This option comes standard with an EPDM gasket (Viton and Kalrez gaskets are also available; see Accessories).

(4) Not available with option -62.

(5) Cables may be extended using the remote junction box PN 23550-00 (sold separately) and extension cables (see Accessories).

(6) Recommended for use with transmitter models 1054 and 2054. May be used with transmitter models 1055, 1056, 1066, 54C, 54eC, 81T, 2081T, 3081T, 4081T, 5081T, and XMT, but not recommended.

(7) Recommended for use with transmitter models 1055, 1056, 1066, 56, 54C, 54eC, 5081, and XMT.

(8) For use with option -54 only. Connects sensor used in valve insertion assembly to junction box. Requires interconnecting cable to connect junction box to transmitter. Use either cable 23294-00 (unshielded) or 23294-05 (shielded).

Specifications

Sensor Specifications

Wetted Materials: Body materials either glass-filled PEEK, glass-filled Tefzel, or unfilled Tefzel. Option-20 has EPDM gasket.

Process Connection: -20: 5/8 in. 11 UNC
-21 : 3/4 in. MNPT

Cable Length: 20 ft (6.1 m)

Maximum Cable Length: 200 ft (61 m)

Weight/Shipping Weight: 2 lb/3 lb (1.0 kg/1.5 kg)

Table 2 - Maximum Operating Temperature and Pressure

Body Material Option	Maximum Temperature	Maximum Pressure	Maximum Pressure (for CRN Registration Only)
-02	248 °F (120 °C)	295 psig (2135 kPa)	220 psig (1618 kPa [abs])
-03	392 °F (200 °C)	295 psig (2135 kPa)	220 psig (1618 kPa [abs])
-04	248 °F (120 °C)	200 psig (1480 kPa)	150 psig (1135 kPa [abs])
-05	248 °F (120 °C)	200 psig (1480 kPa)	150 psig (1135 kPa [abs])

Insertion Adapter Specifications

Adapter Part Number	Sensor Compatibility	Process Connection	Wetted Materials	Maximum Temperature	Maximum Pressure	Maximum Pressure (for CRN Registration Only)	Weight/Shipping Weight
23242-02	For use with option -21	1-1/2 in. MNPT	316 SS, glass-filled PEEK, Viton	392 °F (200 °C)	295 psig (2135 kPa)	220 psig (1618 kPa)	3 lb/4 lb (1.5 kg/2.0 kg)
23242-03	For use with option -20	1-1/2 in. MNPT	316 SS, glass-filled PEEK, Viton	392 °F (200 °C)	295 psig (2135 kPa)	220 psig (1618 kPa)	3 lb/4 lb (1.5 kg/2.0 kg)
2001990	For use with option -21	2 in. MNPT	CPVC, Viton	100 °F (38 °C)	100 psig (791 kPa [abs])	N/A	1 lb/2 lb (0.5 kg/1.0 kg)
				185 °F (85 °C)	45 psig (412 kPa [abs])		

Retraction Assembly Specifications

Sensor Compatibility: The retraction assemblies are used with 228 - []-20-54-62 only

Wetted Materials: 316 stainless steel, ethylene polypropylene (EP), unfilled Teflon, carbon-filled Teflon

Process Connection: 1-1/2 in. MNPT

Maximum Temperature: 392 °F (200 °C)

Maximum Pressure: 295 psig (2135 kPa [abs])

Table 3 - Maximum Retraction/Insertion Conditions

Description	Temperature	Pressure	Maximum Insertion Travel	Weight/Shipping Weight
23311-00, mechanical retraction assembly	392 °F (200 °C)	295 psig (2135 kPa [abs])	10.5 in. (267 mm)	12 lb/15 lb (5.5 kg/7.0 kg)
23311-01, manual retraction assembly	266 °F (130 °C)	35 psig (343 kPa [abs])	12.0 in. (305 mm)	9 lb/12 lb (4.5 kg/5.5 kg)

Ball Valve Specifications (Sold Separately)

Part Number: 9340065

Wetted Materials: 316 stainless steel, Teflon TFE

Process Connection: 1-1/2 in. FNPT

Weight/Shipping Weight: 4 lb/5 lb (2.0 kg/2.5 kg)

Pressure and Temperature:

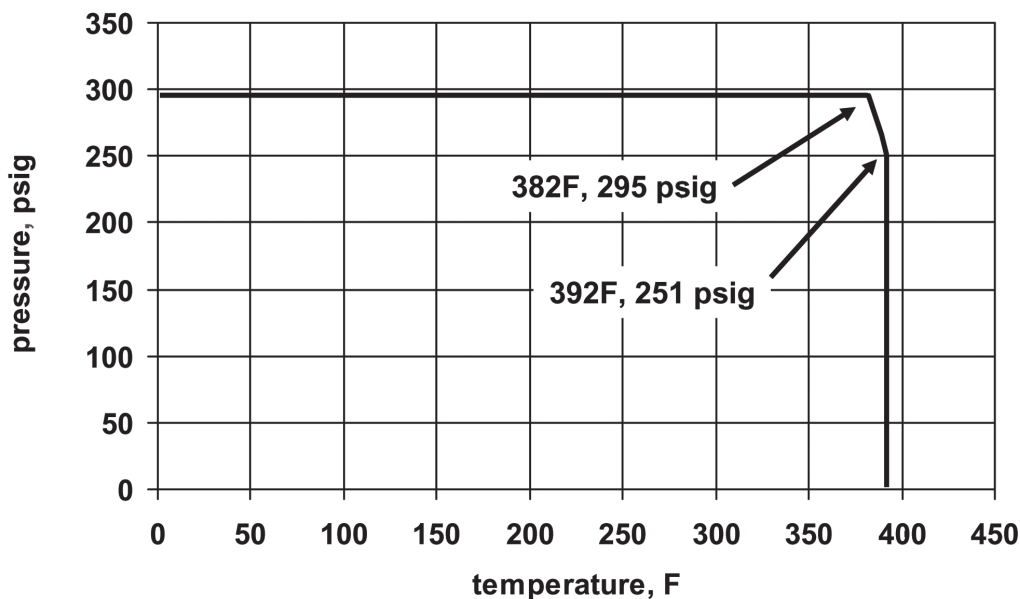

Dimensional Drawings

Figure 1. Rosemount 228 dimensional drawing

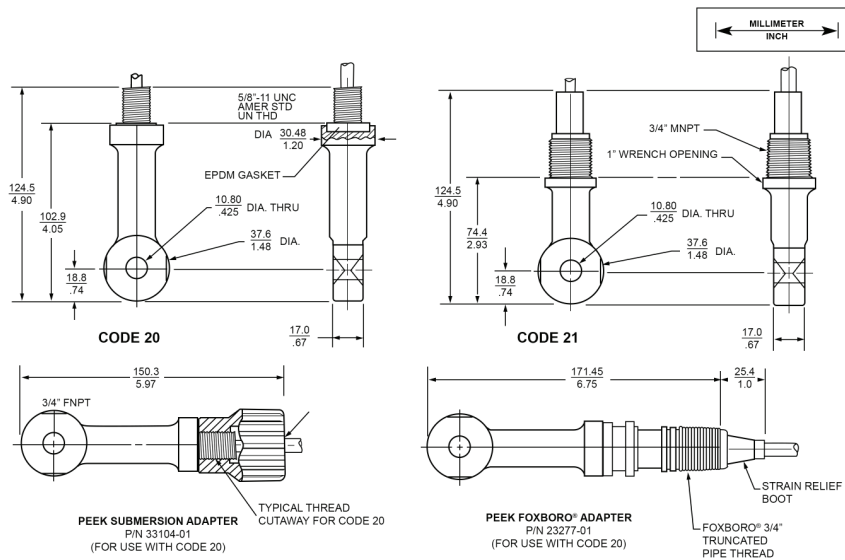

Model 228 Dimensional Drawing

Figure 2. Insertion Adapter 23242-02

Figure 3. Insertion Adapter 23242-03

Figure 4. Insertion Adapter 2001990

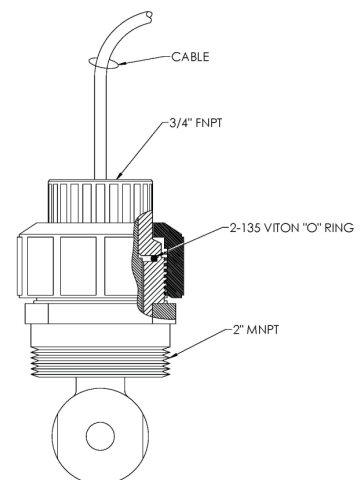
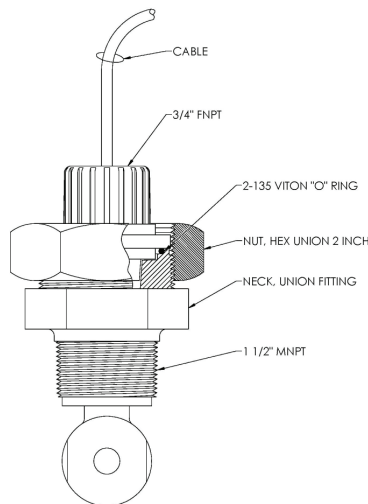
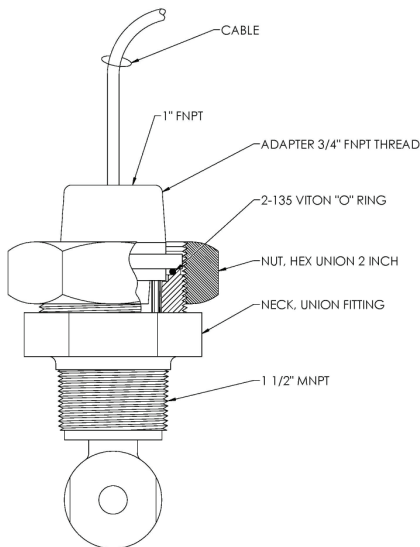

Figure 5. Manual Retraction Assembly PN 23311-01 dimensional drawing

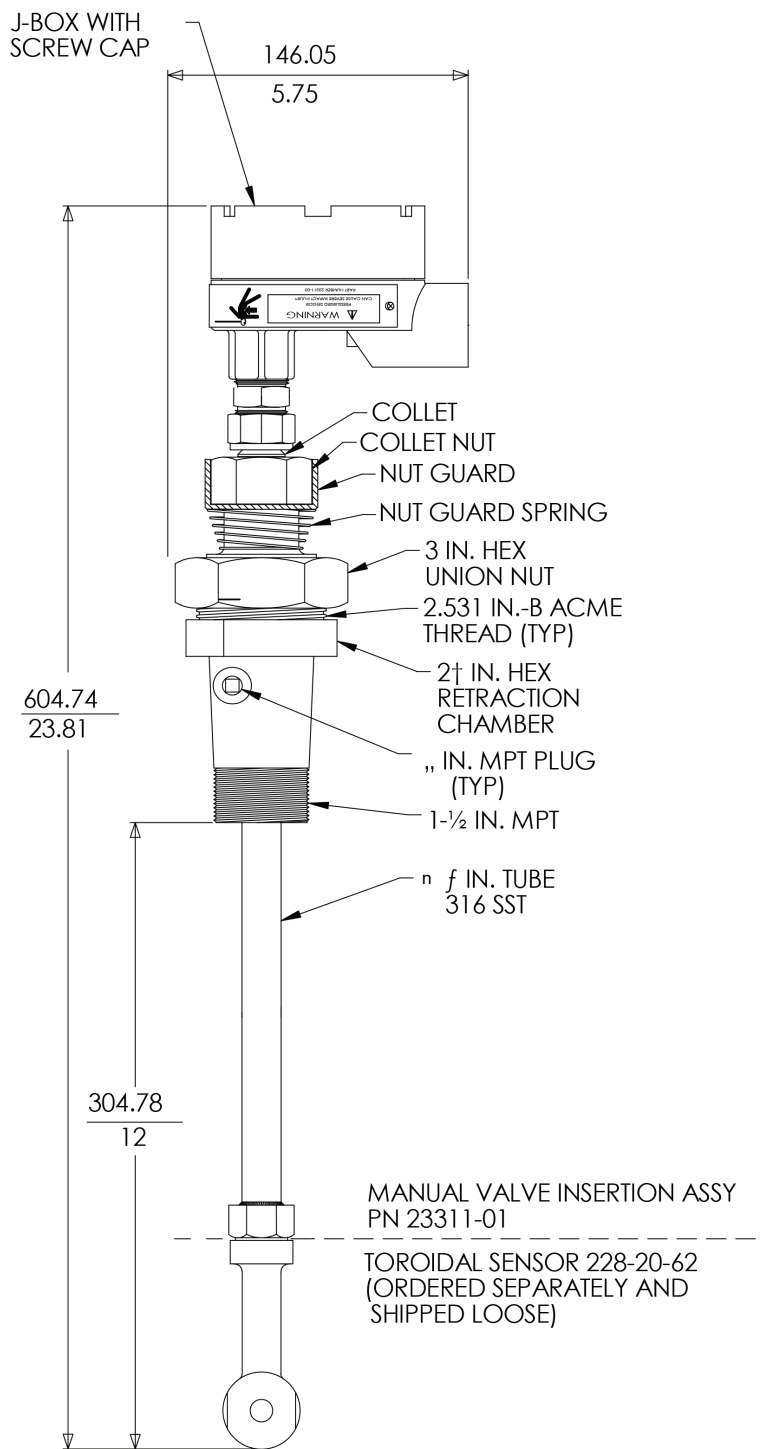
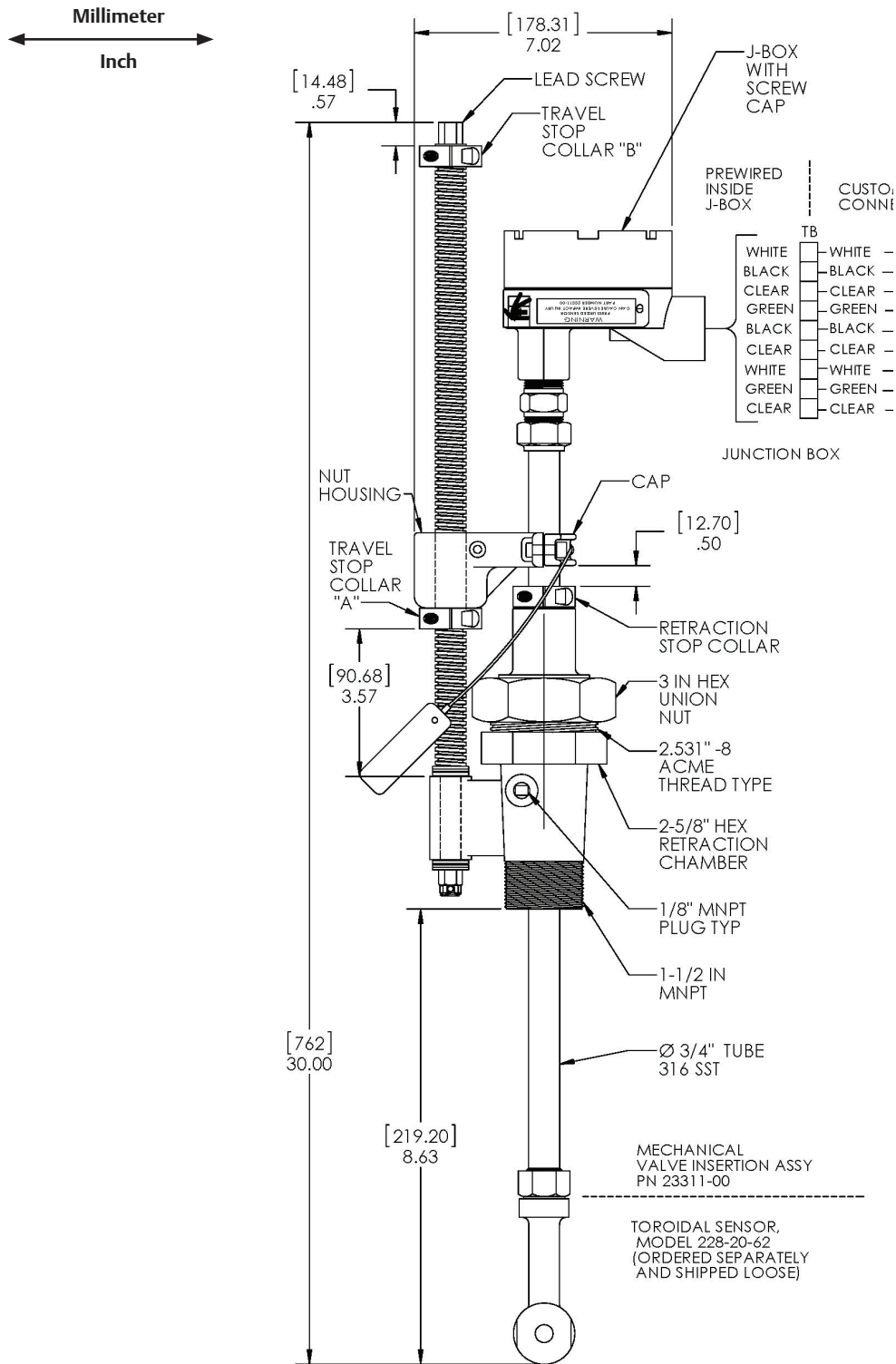

Figure 6. Mechanical Retraction Assembly PN 23311-00 dimensional drawing



Accessories

Part Number	Description
23550-00	Remote junction box
23294-00	Unshielded interconnecting cable
23294-05	Shielded interconnecting cable
23311-00	Mechanical valve insertion assembly
23311-01	Manual valve insertion assembly
2001990	Mounting adapter, 2 in. MNPT, CPVC
9550179	O-ring, EP rubber, for 201990
23242-02	Mounting adapter, 1-1/2 in. MNPT insertion, 1 in. FNPT conduit connection, PEEK
33081-00-99SQ7091A	Adapter insert, Tefzel, for 23242-02
33081-00	Adapter insert, PEEK, for 23242-02
23242-03	Mounting adapter, 1-1/2 in. MNPT insertion, 3/4 in. FNPT conduit connection, PEEK
33080-01-99SQ7182	Adapter insert, Tefzel, for 23242-03
23277-01	Mounting adapter, Foxboro, PEEK, 5/8 11 UNC
23277-01-99SQ7182	Mounting adapter, Foxboro, Tefzel, 5/8 11 UNC
33075-00	Viton gasket for option 20
33075-03	Kalrez gasket for option 20
9200276	Extension cable, unprepped
9340065	1-1/2 in. FNPT full port ball valve for use with retraction assemblies

Notes

Notes

EmersonProcess.com/LiquidAnalysis



YouTube.com/user/RosemountAnalytical



Analyticexpert.com



Twitter.com/Rosemount_News



Facebook.com/Rosemount

AMERICAS

Emerson
2400 Barranca Pkwy
Irvine, CA 92606
USA
Toll Free +1 855 724 2638
F +1 949 863 9159
liquid.csc@emerson.com

EUROPE

Emerson Process Management AG
Neuhofstrasse-19a P.O. Box 2046
CH-6340 Baar
Switzerland
T +41 (0) 41 768 6111
F +41 (0) 41 768 6300
liquid.csc@emerson.com

MIDDLE EAST AND AFRICA

Emerson Process Management
Emerson FZE
Jebel Ali Free Zone
Dubai, United Arab Emirates,
P.O. Box 17033
T +971 4 811 8100
F +971 4 886 5465
liquid.csc@emerson.com

ASIA-PACIFIC

Emerson Process Management
Asia Pacific Private Limited
1 Pandan Crescent
Singapore 128461
Republic of Singapore
T +65 6 777 8211
F +65 6 777 0947
liquid.csc@emerson.com

©2017 Emerson. All rights reserved.

The Emerson logo is a trademark and service mark of Emerson Electric Co. Rosemount is a mark of one of the Emerson family of companies. All other marks are the property of their respective owners.

The contents of this publication are presented for information purposes only, and while effort has been made to ensure their accuracy, they are not to be construed as warranties or guarantees, express or implied, regarding the products or services described herein or their use or applicability. All sales are governed by our terms and conditions, which are available on request. We reserve the right to modify or improve the designs or specifications of our products at any time without notice.