

# Two-Wire In Situ Oxygen Analyzer (550° to 1400°C)

- Intrinsically safe:
  - CENELEC EEx ia IIC
  - Class I Div. I Gr. B, C, D (pending)
- Operates at high temperatures 550° to 1400°C (1022° to 2550°F)
- Assists in low NO<sub>x</sub> operation
- Calibration check ability
- Fast response – no flame arrestors
- Hart®/AMS communications
- Accuracy ±1.5% of reading

## MEASURES CLOSER TO THE FLAME WHILE MAINTAINING INTRINSIC SAFETY

Traditional in situ oxygen flue gas analyzers utilize zirconium oxide sensors to measure excess oxygen in process flue gas. These zirconium oxide sensors use a principle of operation based on the Nernst equation. This principle requires that the sensor cell be maintained at a high operating temperature using a heater that is powered via the analyzer's electronics.

Many operators of combustion processes have applications that involve hazardous gases in the process itself or in the ambient gases in the area where the analyzer's electronics are installed. These operators are often concerned that the cell heater can serve as an ignition source to these hazardous gases inside the process or that the electronics can provide ignition to hazardous process or ambient gases that may be present. As a result of these concerns, these users must purchase oxygen analyzers with costly protection features.

In addition, traditional in situ oxygen analyzers use metallic alloys that are also limited to temperatures in the range of 701°C (1300°F). This process temperature limitation prohibits the analyzer from being inserted close to the actual combustion process. Many operators prefer to measure flue gas oxygen close to the furnace or radiant section for a more representative oxygen measurement. Improved analyzer accuracy often results in significant fuel savings or improved process throughput.

The Model 5081FG Two-Wire In Situ Oxygen Analyzer utilizes a zirconium oxide sensor to measure excess oxygen in combustion processes. The cost-effective design enables it to accurately measure excess oxygen in process temperatures ranging from 550° to 1400°C (1022°



to 2550°F). In addition, the Model 5081FG is designed so that both its oxygen probe and the electronics are intrinsically safe without requiring costly design modifications such as flame arrestors. The oxygen probe is constructed of ceramic materials capable of withstanding high process temperatures. Also, the analyzer eliminates the use of the cell heater, using the higher process temperatures to heat the zirconium oxide sensor cell to the temperature required by the Nernst equation principle of operation.

The Model 5081FG analyzer's electronics are intrinsically safe, powered by the 4-20 mA signal wires. In addition, the electronics permit configuration, operation and diagnostics with an easy-to-use hand-held Infrared Remote Control (IRC). Only one IRC is required to communicate with any number of Model 5081FG Two-Wire In Situ Oxygen Analyzers at the user's location. Communication with any specific Model 5081FG Analyzer is accomplished by aiming the IRC beam directly at the electronics and entering its factory or user ID number at the prompt. This instrument can also communicate over the 4-20 mA signal wires with a HART® communicator or Emerson Process Management AMS software.

## Applications

- Process heaters – hazardous areas
- Reactor furnaces – hazardous areas
- Boiler radiant zones
  - measures before air leaks
  - tuning individual burners
  - NO<sub>x</sub> reduction
- Sulfur recovery furnaces
- Hazardous waste incinerators
- Steel reheat furnaces
- Glass furnaces
- Carburizing furnaces

**ROSEMOUNT®**  
Analytical

Visit our website at [www.raihome.com](http://www.raihome.com)  
On-line ordering available.

  
**EMERSON™**  
Process Management

# MODEL 5081FG TWO-WIRE IN SITU OXYGEN ANALYZER FEATURES AND BENEFITS

FEATURES	BENEFITS
Both the analyzer's in situ probe and the electronics are intrinsically safe.	Provides protection from hazardous process or ambient gases, preventing explosions without requiring field-mounted electrical barriers, flame arrestors or special enclosures. Explosion-proof conduit is not required for cabling.
Operates in process gases ranging from 550° to 1400°C (1022° to 2550°F).	Provides accurate oxygen flue gas analysis closer to the flame in boiler applications; enables accurate flue gas analysis in high temperature process heater or furnace applications.
Provides HART®/AMS communications.	Provides convenient and cost-effective operator access to key analyzer parameters; provides analyzer diagnostic capabilities from the terminations room, instrument maintenance shop or control room.
Provides accuracy of ±1.5% of reading.	Best accuracy specification for analyzer of its type in the industry; enables tighter energy control in process which helps user reduce energy costs; improves process throughput.

## MODEL 5081FG OPERATOR INTERFACE

The Model 5081FG Oxygen Two-Wire In Situ Analyzer is also an Emerson Process Management SMART instrument. Operators can communicate with the Model 5081FG Analyzer using the Model 375 HART® Communicator and any other host that supports HART communication protocol such as Emerson Process Management's AMS system. Using AMS, operators may diagnose and communicate with the Model 5081FG Analyzer from a centrally located PC, which may also be communicating with all HART-compatible instruments within the operator's plant.

## Calibration Check Capability

The Model 5081FG offers the ability to flow calibration gases to the probe for calibration check. This feature helps ensure that your Model 5081FG analyzer is performing within calibration and its specifications, providing accurate oxygen flue gas measurements to help you save fuel or improve process throughput.

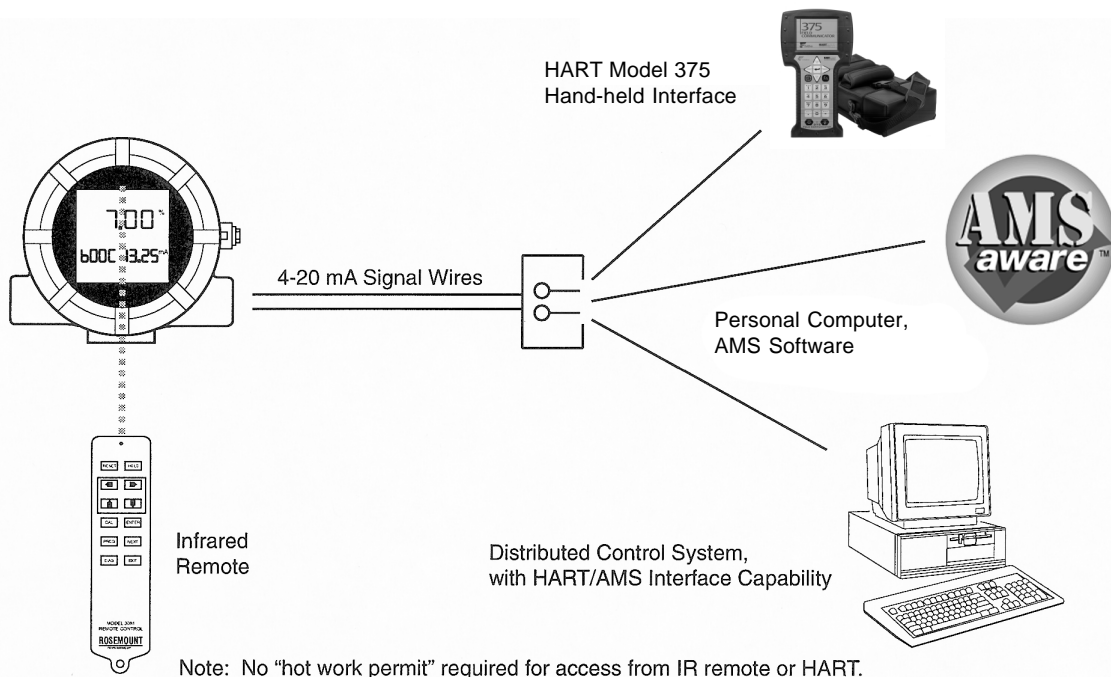

## SPECIFICATIONS

### GENERAL

<b>Net O<sub>2</sub> range:</b>	0-25%
<b>System accuracy:</b>	±1.5% of reading or 0.05% O <sub>2</sub> , whichever is greater
<b>System speed response in flue gas:</b>	Initial response – less than 3 seconds T <sub>90</sub> response – less than 10 seconds

### PROBE

<b>Lengths:</b>	508 mm (20 in.) 660 mm (26 in.) 965 mm (38 in.)
<b>Process temperature limits:</b>	550° to 1400°C (1022° to 2550°F)
<b>Ambient temperature limits:</b>	-40° to 149°C (-40° to 300°F)
<b>Materials of construction:</b>	
<b>Process wetted parts:</b>	
<b>Inner probe:</b>	Zirconia
<b>Outer protection tube:</b>	Alumina [1600°C (2912°F) limit] Iconel [1000°C (1832°F) limit]
<b>Probe junction box:</b>	Cast aluminum
<b>Speed of installation/withdrawal:</b>	25.4 mm (1 in.) per minute
<b>Hazardous area certification:</b>	Intrinsically safe per EN50 014 (1977), clause 1.3 <sup>1</sup>
<b>Reference air requirement:</b>	100 ml per minute (2.119 scfh) of clean, dry instrument air; 1/4 in. tube fittings
<b>Calibration check gas fittings:</b>	1/4 in. tube fittings
<b>Cabling:</b>	Two twisted pairs, shielded

### ELECTRONICS

<b>Enclosure:</b>	IP 65 (NEMA 4X), weatherproof, and corrosion-resistant
<b>Materials of construction:</b>	Low copper aluminum
<b>Ambient temperature limits:</b>	-20° to 65°C (-4° to 149°F)
<b>Relative humidity:</b>	95% with covers sealed
<b>Power supply and load requirements:</b>	See graph below
<b>Inputs (from O<sub>2</sub> probe):</b>	Two wires – O <sub>2</sub> signal Two wires – type B thermocouple
<b>Output:</b>	One 4-20 mA signal with superimposed digital HART signal
<b>Hazardous area certification:</b>	ATEX EEx ia IIC T4 or T5 <sup>2</sup> NEC Class I Div. I Group B, C, D
<b>Power transient protection:</b>	IEC 801-4
<b>Shipping weight:</b>	4.5 kg (10 lbs.)

### INFRARED REMOTE CONTROL

<b>Power requirements:</b>	Three AAA batteries
<b>Hazardous area certification:</b>	ATEX EEx ia IIC Class I Div. I Group A, B, C, D

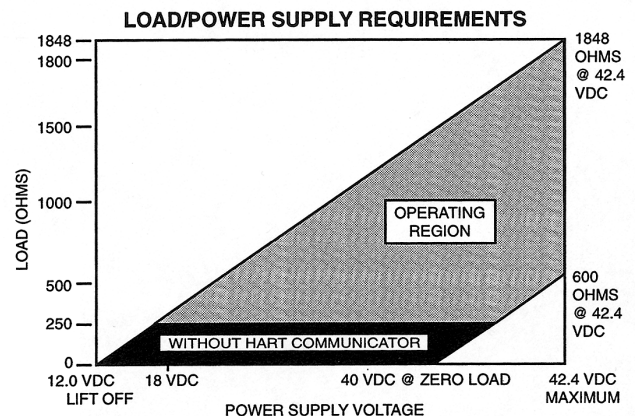

<sup>1</sup> Thermocouple and O<sub>2</sub> probe cell are both unpowered, developing a millivolt emf, and are considered a "simple apparatus" by certifying agencies.

<sup>2</sup> Dependent on ambient temperature limits.

# MODEL 5081FG PROBE MOUNTING DIMENSIONS

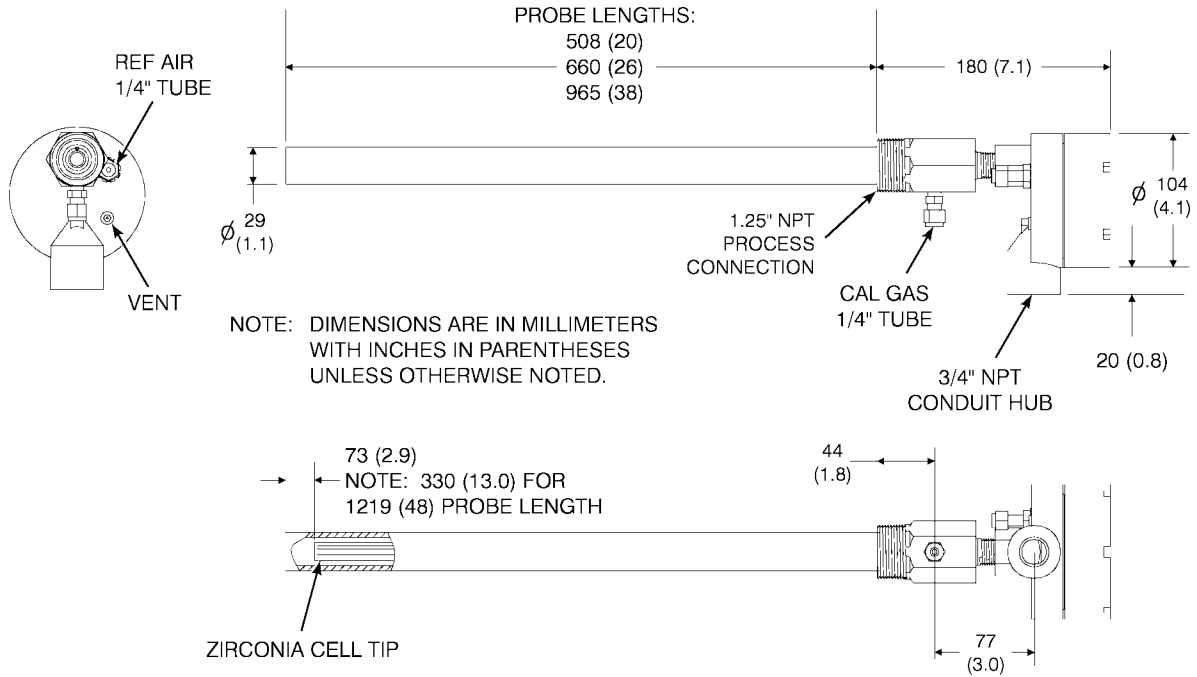

# MODEL 5081FG ELECTRONICS MOUNTING DIMENSIONS

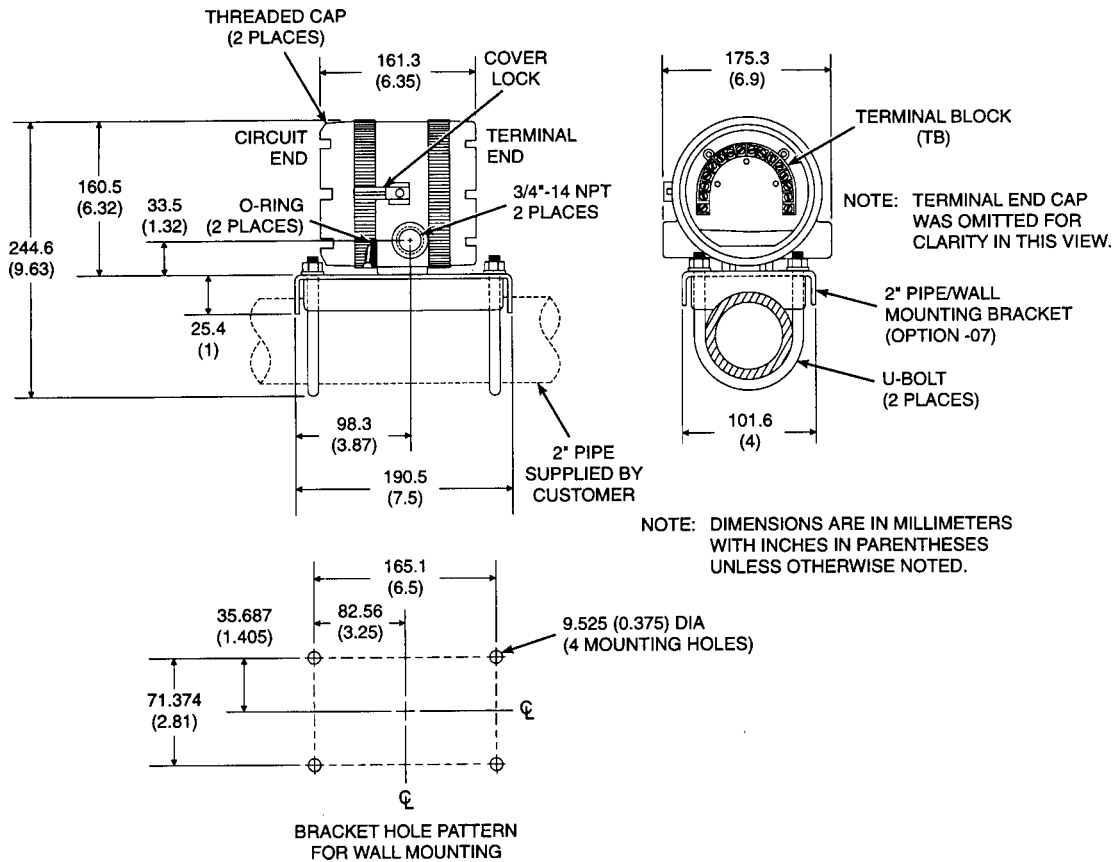

## MODEL 5081FG ORDERING INFORMATION

Model	Description
5081FG	In-Situ Oxygen Analyzer – Hi-Temp 2-Wire HART® Smart (550-1600°C) (5081FG)
<b>Level 1 Sensing Probe Length</b>	
1	20" Probe, 1/4" Tube Fittings
2	26" Probe, 1/4" Tube Fittings
3	38" Probe, 1/4" Tube Fittings
<b>Level 2 Probe Outer Tube Material – Maximum Operating Temperature</b>	
1	Alumina – 1600°C maximum – 1 1/4 NPT mounting
3	Inconel Alloy – 1000°C maximum – 1 1/4 NPT mounting
<b>Level 3 Mounting Adapter (stack side)</b>	
0	No adapter plate required; uses 1 1/4 NPT
1	New Flanged Installation-Square Weld Plate with Studs
2	Westinghouse Model 450 Mounting
3	Competitor's Mount
<b>Level 4 Mounting Adapter (probe side)</b>	
0	No Adapter Plate
1	ANSI 2" 150 lb. Flange to 1 1/4 NPT Adapter
2	DIN to 1 1/4 NPT Adapter
3	JIS to 1 1/4 NPT Adapter
4	Model 450 to 1 1/4 NPT Adapter
5	Competitor's Mounting Flange
<b>Level 5 Electronics and Housing – Intrinsically Safe, NEMA 4X, IP 66</b>	
00	HART, no certification
H0	HART Electronics
H1	HART Electronics – CENELEC EEx ia IIC T4
H2	HART Electronics – CSA Class I, Div. 1, Groups B, C, D
H3	HART Electronics – FM Class I, Div. 1, Groups B, C, D
<b>Level 6 Housing Mounting</b>	
00	Surface or Wall Mounting
01	1/2 to 2" Pipe Mounting
<b>Level 7 Communications (HART® standard)</b>	
0	No Remote Control
1	Infrared Remote Control (LCD display through cover)
<b>Level 8 Calibration Accessories</b>	
0	No Hardware
1	Cal/Ref Flowmeters and Ref Pressure Regulator
<b>Level 9 Special Armored Cable Length</b>	
00	No cable
11	20' (6 m)
12	40' (12 m)
13	60' (18 m)
14	80' (24 m)
15	100' (30 m)
16	150' (45 m)
17	200' (61 m)
18	300' (91 m)
19	400' (122 m)
20	500' (152 m)

*The contents of this publication are presented for informational purposes only, and while every effort has been made to ensure their accuracy, they are not to be construed as warranties or guarantees, express or implied, regarding the products or services described herein or their use or applicability. All sales are governed by our terms and conditions, which are available on request. We reserve the right to modify or improve the designs or specifications of our products at any time without notice.*

**Emerson Process Management**

**Rosemount Analytical Inc.  
Process Analytic Division**

6565 P Davis Industrial Parkway

Solon, OH 44139 USA

T 440.914.1261

Toll Free in US and Canada 800.433.6076

F 440.914.1271

e-mail: [gas.csc@EmersonProcess.com](mailto:gas.csc@EmersonProcess.com)

[www.raihome.com](http://www.raihome.com)



**EMERSON**<sup>™</sup>  
Process Management