

Electronic Pressure Controller

Digital, PID Control

ER3000 Series

Description

The ER3000 Electronic Pressure Controller, combined with a wide range of pressure regulators and an external transducer, provides true distributed control of liquids or gases from vacuum to 20,000 PSIG. As a stand alone unit, the ER3000 can control the pressure of dry, clean inert gases from 0 to 100 PSIG. It will give your system closed loop feedback control with exceptional accuracy and response time.

ER3000SI - Standard ER3000 Features:

- Precise accuracy (+/- .1%) from 0-100 PSIG
- Compatible pressure regulators available from vacuum to 20,000 PSIG with flow capacities of $C_V = .02$ to 45
- Control algorithms for I/P, external feedback or cascade control modes
- Selectable setpoint signal source
 - External analog: 4-20 mA or 1-5 VDC
 - Digital RS485 (no A/D or D/A boards necessary)
 - Downloaded profile (runs independent of PC)
- Selectable feedback signal source
 - Internal 0-100 PSIG sensor
 - External analog: 4-20 mA or 1-5 VDC
- Selectable failsafe features
 - Programmable limits for analog setpoint, feedback, and error signals
 - Failsafe states: hold last pressure, vent, or full open
- Non-interacting zero and span
- Watertight, corrosion resistant NEMA 4X enclosure
- Windows® 95/98/NT/2000, 3.1 and MS-DOS® software provided for data acquisition, PID tuning (real time graphic display of setpoint and feedback), debugging, and pressure profiles
- Protocol software provided for easy customization as a DLL in Windows® 95/98/NT/2000 and 3.1, 'C' library in MS-DOS®, and software for the Mac®OS
- May be used with UI4000
- Software examples are provided for LabVIEW™, Visual Basic®, LabWindows/CVI™, and Visual C++® in Windows® 95/98/NT/2000 and 3.1 and 'C' in MS-DOS®
- As many as 32 ER3000 Controllers can be networked at a distance up to 4000 feet away via a 2-wire RS485 link
- Vacuum may be controlled by using just the ER3000 and a subatmospheric transducer

ER3000SV - Standard ER3000 Features:

- All features of the ER3000SI except analog setpoint and feedback signals are 0-10 VDC



ER3000FI & ER3000FV - Enhanced ER3000 Features:

- All features of the ER3000SI and ER3000SV are included
- Two additional analog/digital inputs allow the user to:
 - Monitor an external signal in addition to feedback (e.g. flow, temperature)
 - Start/stop (or resume/stop) and pause pressure profiles
 - Alternate between two separate external feedback sources
 - Wait for an event to occur before proceeding to the next step in a downloaded profile (digital input)
 - Indicate that a step has occurred in a downloaded profile (digital output)
- Analog sensor output

ER3000EX, ER3000GX & ER3000H - Explosion Proof Features:

- Explosion proof versions of ER3000SX, ER3000FX and ER3000U have Factory Mutual (FM) approval for use in Class I, Division I, Groups B, C, and D areas
- Approvals: FM, CSA and CE*

ER3000MX, ER3000NX & ER3000P - KEMA Explosion Proof Features:

- Explosion proof versions of ER3000SX, ER3000FX and ER3000U have KEMA approval for use in areas per (EEx d IIB + H₂ T4)
- Approvals: KEMA and CE*

*All ER3000-X Series units have CE approval when wired per CE approved wiring instructions in the manual.

Windows®, WindowsNT®, Visual Basic®, MS-DOS® and Microsoft® Excel are registered trademarks of Microsoft Corp.
Mac®OS is a registered trademark of Apple Computers, Inc.
LabVIEW™ and LabWindows/CVI™ are trademarks of National Instruments.
Viton®, Kalrez®, Teflon® & Vespet® are registered trademarks of DuPont Corp.

Monel® is a registered trademark of Huntington Alloys.
Hastelloy® is a registered trademark of Haynes International, Inc.
Aminco® is a registered trademark of Carpenter Technology, Inc.
Stentor® is a registered trademark of American Instrument Co.
Lotus® is a registered trademark of Lotus Development Corp.

TESCOM
CORPORATION

Global technical support & distribution • Design & manufacturing facilities in the U.S., Germany & Asia

Specifications

□ Electrical

1. Power Requirement 20.5 to 28.5 VDC, 340 mA maximum, 180 mA nominal
2. Turn-on Time <240 milliseconds
3. Restart from Power Interruption <1.9 seconds

□ Supply Requirement

1. Media Type Clean, dry inert gas or shop air
2. Pressure Minimum: Output Pressure + 1 PSIG, Maximum: 120 PSIG, Nominal: 110 PSIG
3. Temperature -20° F to 170° F (-30° C to 75° C) (dry media required below 32° F)
4. Filter In line 40 micron filter recommended

□ Input Signal

1. Setpoint 4-20 mA, 1-5 VDC or Digital RS 485 (0-10 VDC for ER3000XV)
2. Feedback (*external*) 4-20 mA or 1-5 VDC (0-10 VDC for ER3000XV)

□ Performance

1. Accuracy (*Internal Sensor*)
 - Linearity ±0.05% Full Scale Output (FSO)
 - Hysteresis ±0.05% (FSO)
 - Repeatability ±0.05% (FSO)
 - Resolution Sensitivity ±0.03% (FSO)
 - Measured Reference Accuracy (*total accuracy all effects including Zero and Span Error*) ±0.10% (FSO)
 - Temperature Effect ±0.002% / degrees F of FSO (-20° F to +170° F)
±.0036%/ degrees C of FSO (-30° C to 75° C)
- Low Pressure Capability with External Transducer ±0.25 inches water (.635 g /sq. cm) into 2 liter volume
2. Response Time
 - Lift Off <70 milliseconds
 - Rise Time [10-90 PSIG (.69- 6.21)] 350 milliseconds [1 cubic inch volume (32.8 cc)]
 - Fall Time [90-10 PSIG (6.21-.69)] 650 milliseconds [1 cubic inch volume (32.8 cc)]
 - Frequency Response
 - Amplitude Attenuation -3db @ 2 Hz
 - Phase Shift -90 degrees @ 2 Hz
3. Flow Capacity $C_v=0.01$ (Maximum Flow = 18 lpm)
4. Solenoid Valve Rated Cycle Life >150 million cycles

□ Physical

1. Size
 - Gas Ports (*Inlet, Exhaust & Gauge*) 1/8 inch - 27 NPT
 - Controlled Outlet Port 1/4 inch -18 NPT
 - Internal Volume 16.3 cubic inches (267 cc)
 - Length 4.2 inches (106.7 mm)
 - Diameter 3.72 inches (94.5 mm)
 - Conduit Openings Two, 1/2 inch NPT
2. Weight 34.8 oz. (1.0 kg)
3. Housing Rating
 - Standard NEMA 4X (cast aluminum & epoxy polyester paint)
 - Explosion Proof Version CSA and FM approval for Class I, Division 1, Groups B, C and D locations
 - European Explosion Proof Version KEMA approval per (Ex d IIB + H₂ T4)
4. Flow Stream Materials
 - Solenoids nickel plated brass, Viton® seat and o-rings
 - Sensor glass, ceramic, silicon, RTV, nickel
 - Manifold glass filled PET
 - Tubing polyurethane
 - Plug brass
 - O-rings Silicone, Buna-N, Viton®
5. Mounting Four 8-32 UNC holes
6. Mounting Orientation Effect None

□ Environment

1. Temperature Range -20° F to +170° F (-30° C to +76° C)
2. Relative Humidity 98% @ 65° C (cover off - no effect)
3. Vibration
 - Resonance Sweep 5 Hz to 2000 Hz @ .5 g constant acceleration
 - Resonance Dwell 5 minutes at each resonance point (3 axis)
 - Sine Sweep5 octaves / minute, 5 Hz to 2000 Hz (3 axis)
5 Hz to 10 Hz @ 10 mm constant displacement
10 Hz to 2000 Hz @ 2.0 g constant acceleration (No effect)
4. Storage Temperature -58° F to 200° F (-50° C to +95° C)

ER3000 Basics

ER3000 Basics

All ER3000 Controllers require 24 VDC with a minimum of 250 mAmps, up to 120 PSIG shop air supply and a setpoint signal. The ER3000 is shipped configured to accept an analog setpoint, either 1-5 volts or 4-20 mAmps (0-10 VDC for ER3000XV). This can be changed to accept a digital setpoint from a computer over the RS485 network using the provided software. This software also allows the user to tune and monitor the system and acquire data. If the ER3000 is used in External or Cascade mode, an analog 1-5 volt or 4-20 mAmp (0-10 VDC for ER3000XV) feedback signal is also required.

ER3000 Tuning

Since PID parameters need to change between static (dead-ended) and dynamic (flowing) pressure states, the ER3000 has the flexibility to be tuned for different system conditions. The Proportional, Integral and Derivative (PID) variables are adjustable to:

- achieve the quickest response to a setpoint change without overshoot or oscillation
- achieve the best performance for a non-changing setpoint

Tescom presets PID variables as standard, or customized for a specific Tescom regulator. The user can then optimize the PID parameters after installation for best possible static and/or dynamic results to satisfy the user's system requirements using communication software provided in Windows® or MS-DOS®.

ER3000 Communication

The ER3000 communicates using an RS485 based protocol developed at Tescom. The protocol is nonproprietary, allowing users to develop their own software to interface with a device, such as a PLC, that is not MS-DOS® or Windows® based.

ER3000 Software

The ER3000 protocol software is provided to assist in developing process control software that communicates with the ER3000. The protocol is available as a DLL for Windows® 95/98/NT/2000 and 3.1, a 'C' library for MS-DOS®, and for the Mac®OS. The protocol software uses six functions to communicate to the ER3000. The functions are: StartUp, ReadNetVar, WriteNetVar, ReadProfileSegment, WriteProfileSegment, and Shutdown.

MS-DOS® Programs Provided

TUNE, ERTALK, DEBUG, PROFILE, PROFILE 2 AND DATA_LOG.

ER3000 Modifications

ER3026X-1 Integrated Pressure Control Systems

The base of the ER3026X-1 is designed to integrate with either a 26-102XXXXA-568 Double Piston Regulator or a 269-529-04IM and 269-529-06IM Flow Boosters. See Modification Table in the Part Number Selector section for details.

ER3000X-2 Low Flow Controller

Designed for use in slow response applications such as analyzers, temperature control or flow control. The ER3000X-2 is equipped with low flow solenoid valves that match the ER response to the system response.

ER3000X-4 High Flow Controller

Designed for use in high flow applications, this ER3000 may be used to deliver up to 5 SCFM ($C_v=0.09$).

ER3000SI-1W Prewired Controller

The ER3000SI-1W is designed to provide a 'turnkey system' for the customer. The unit comes complete with the power supply and converter kit wired directly to the ER3000SI-1.

ER3100 Series High Pressure Controller

See ER3100 Series catalog sheet (Form #1923) for information.

ER3000 Tescom's Windows® Tune Software Features

Tescom's Windows® Tune program is an all encompassing software package which allows the user to address any ER3000 Controller on the RS485 network and is typically used for simple tuning of ER3000s. Additionally, the Tune program allows you to monitor system operation, alter profiles, specify failsafe limits, enable password protection, read/write internal variables, acquire data and review previously acquired data*. The basic screens available are; Signal Generator, Plot, Tuning, Profile, Pulse, Failsafe, Data Acquisition, Dacq View, Miscellaneous, Read/Write, and Password. See examples below.

***Note:** A math coprocessor is required to run the Windows® Tune software program.

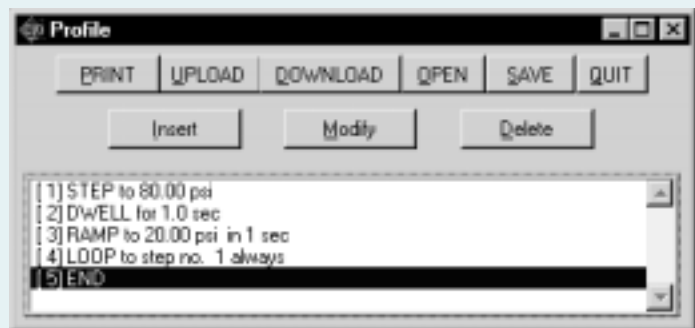
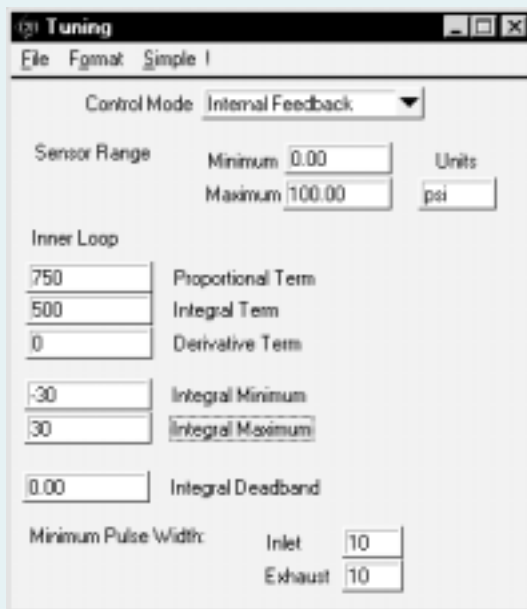
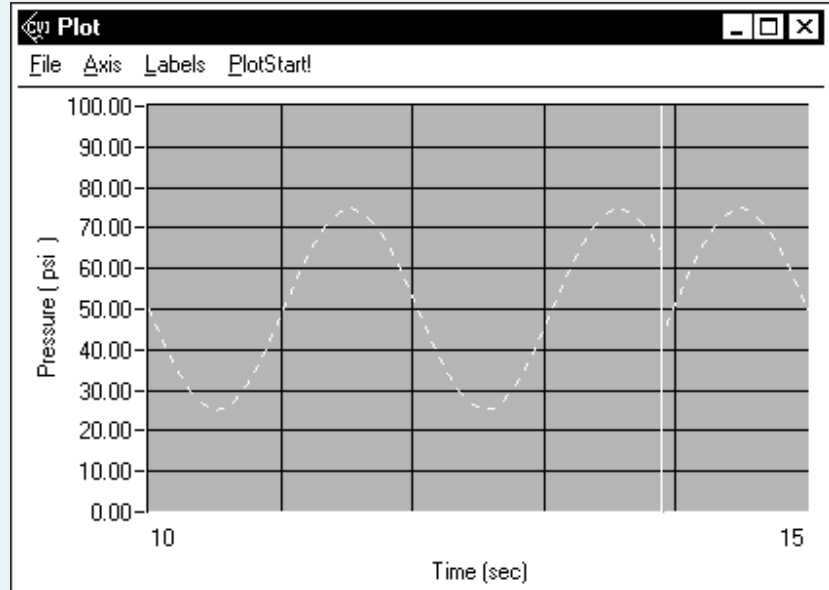
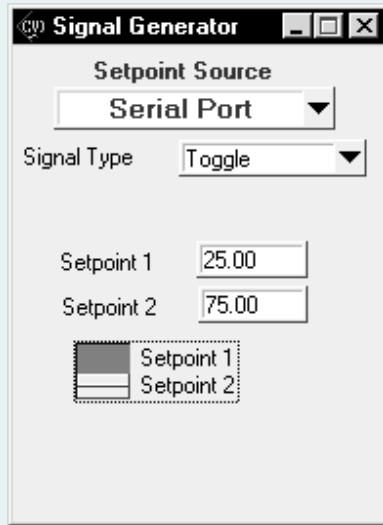

ER3000 Series Electronic Pressure Controller

Part Number Selector

example part number:

ER30 00 S I - 1

BASIC SERIES	BASE STYLE	CONFIGURATION OPTIONS	ANALOG SIGNALS	MODIFICATIONS
ER30	00 – Standard Base 26 – Integrated Regulator	S – Standard F – Enhanced U – User Interface E – Explosion Proof G – Explosion Proof/Enhanced H – User Interface/Explosion Proof M – KEMA, Explosion Proof N – KEMA, Explosion Proof/Enhanced P – KEMA, Explosion Proof/User Interface	I – 40 - 20 MA / 1 - 5 VDC V – 0 - 10 VDC	1 – Standard for ER3000X 2 – Low flow solenoid valve ER3000X 4 – High flow solenoid valve ER3000X 1W – Prewired ER3000S
				<p>For Model ER3026XX-1 (Integrated Regulator), order one of the below:</p> <ul style="list-style-type: none"> Regulator 269-529-04I (Outlet: 0-90 PSIG) Regulator 269-529-04IM (Outlet: 0-300 PSIG) Regulator 269-529-06IM (Outlet: 0-300 PSIG) Regulator 26-1021D24A-568 (Outlet: 15-10,000 PSIG) Regulator 26-1021T24A-595* Regulator 26-1022D24A-568 (Outlet: 10-6000 PSIG) Regulator 26-1024D24A-568 (Outlet: 5-2500 PSIG) Regulator 26-1025D24A-568 (Outlet: 3-1500 PSIG) <p>* Consult factory for specifications on this modification</p>

Note: When combining the ER3000 with a Tescom regulator or other control device, please indicate the device part number on the order to ensure the ER3000 is programmed with the optimal PID parameters for that combination.

Please see ER3100 Series (Form #1923) catalog sheet for ordering information on that series.

Accessories

PART NUMBER	DESCRIPTION
85061	RS232 to RS485 Converter Kit (plugs into standard PC serial port). Includes: 2" x 2" converter and 9 to 25 pin cable.
82575-25	Power Supply for ER3000SX (Output: 24 VDC @ 250 mA / Input: 120 VAC, 60 HZ)
82575-50	Power Supply for ER3000U (Output: 24 VDC @ 500 mA / Input: 120 VAC, 60 HZ)
UI4000	User interface display and programmer for use with all ER3000 and ER3100 Series controllers

Regulator Selection For The ER3000

SPECIFICATION REQUIRED	EXPLANATION
1. Inlet & Outlet Pressure	For best resolution, select the regulator with an outlet range nearest (yet above) the maximum application pressure. Regulator inlet pressure must be acceptable.
2. Flow Rate	The regulator should be capable of the correct calculated C _v value for the application.
3. Media	Media should be compatible with the regulator's materials of construction.

Compatible Tescom Pressure Regulators

REGULATOR SERIES	MAXIMUM INLET PRESSURE (PSIG)	MAXIMUM OUTLET PRESSURE (PSIG)*	FLOW CAPACITY (Cv)	VENT WITH ER
Low Pressure / Diaphragm Regulators				
44-22XX-XXX-XXX	3000, 400	60	.06, .15, .24	NO
44-26XX-XXX-XXX	3500, 500, 400	500, 60	.02, .06, .15, .24	NO
44-28XX-XXX-XXX	3000	450, 60	.08, .16	NO
44-32XXHXXX-XXX	3000, 500	500, 80	1.0, 1.8	NO
44-46XX-XXX-XXX	500, 120	450, 60	.02, .06, .24	NO
44-50XXXX-XXX	3500, 120	60	.06, .24	NO
DHDXXXXXXXXXX	300	100	5.0	YES
High Pressure Regulators				
44-40XXXX-XXX	6000, 3500	3500, 1500, 600	.7, 2.0	YES
26-10XX-XX-XXXA	15000, 10000, 6000	10000, 6000, 2500, 1500, 200	.02, .06, .12	NO
44-13XX-XXXX-AXXX	4500, 3750	1500, 1000, 600, 400, 300, 200	.8, 2.0	NO
44-11XX-XX-XXXA	10000, 6000	6000, 2500, 1500	.02, .05, .12	NO
26-20XX-XXXAXXX	15000, 10000, 6000	10000, 6000, 2500, 1500	.02, .06, .12	YES
44-52XX--XXX	3500	500	.06, .15	YES
Back Pressure Regulators				
26-23XXXXXXA	500, 100, 60	N/A	.06, .6, 1.0	N/A
44-47XX-XX-XXX	60	N/A	.04, .30	N/A
26-17XX-XX-XXXA	ten pressures up to 10000	N/A	.02, .1, .14, .6	N/A
269-350-XXX	100	N/A	.6	N/A
269-465-XXX	500	N/A	.6	N/A
44-23XX-XX-XXX	50	N/A	.08	N/A
54-27XXXXXXA	500	N/A	2.0, 5.0	N/A
Hydraulic Regulators				
54-20XXXXXXA	15000, 10000	15000, 10000, 6000, 2500, 1500	.06, .2	YES
54-21XXXXXXA (Back Pressure)	15000, 10000, 6000, 2500, 1500, 100	N/A	.08	N/A
54-22XXXXXXA	8000	8000, 5000, 2500, 100	2.0	YES
54-23XXXXXXA (Back Pressure)	10000, 5000, 2500, 1150, 200	N/A	1.7	N/A
54-28XXXXXXA	5000	5000, 3500, 1500, 600, 100	8.0	YES
Specialty				
269-493-XXXXX	1000, 250	700, 100	.5	YES
269-529-XX	300	90	1.5 - 45.0	YES
269-545-XXXXX	10000, 6000	500	.02, .06, .12	YES

*Maximum outlet pressures are for regulators used with an ER3000 with an ER3000 input pressure of 110 PSIG.

Installation Dimensions

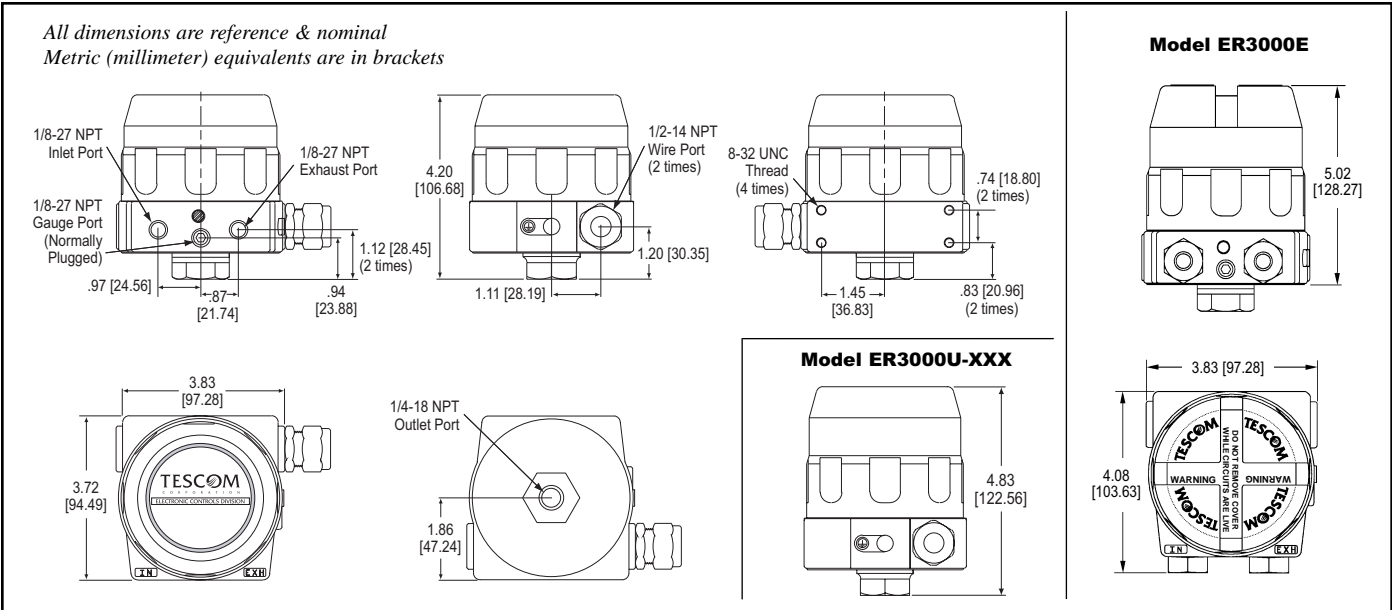

Typical Applications

The variety of applications is limitless. Any process variable that can be manipulated using the pneumatic output of the ER3000 can be controlled. Some possibilities include controlling pressure, flow, temperature, position, speed, force, consistency, torque and acceleration. The ER3000 improves both speed and accuracy because it implements the control strategy directly at the control element (valve or regulator). Some possible applications include:

- Test stands
- Calibration
- Laser cutting systems
- Vacuum forming
- Super plastic metal forming
- Plastic extrusion
- Gas assisted plastic injection molding
- Lamination and composite material curing
- Tire molding
- Chromatography capillary inlet pressure
- Spray coating
- Water jet cutting
- Burst Testing
- High pressure gas or liquid injection
- Pilot plants
- Replacement for valve positioners and I/Ps
- Spot welding pressure control

ER3000 Application Diagrams

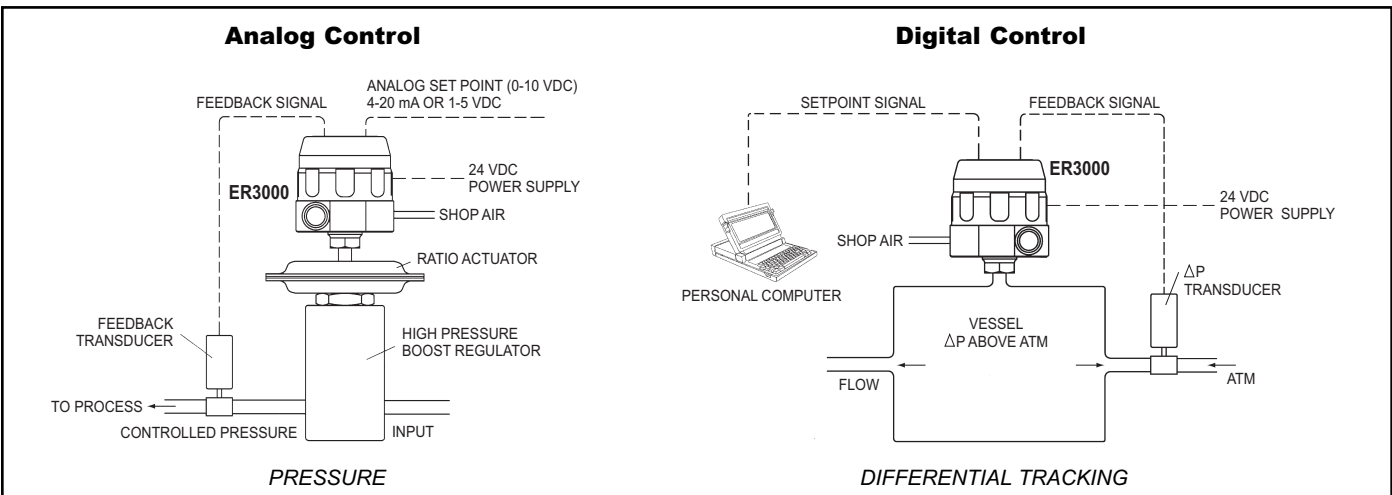

WARNING! Do not attempt to select, install, use or maintain this product until you have read and fully understood the Tescom Safety, Installation & Operation Precautions.

NOTE: Product availability and specifications contained herein are subject to change without notice. Consult local distributor or factory for potential revisions and/or service related issues.

TESCOM
CORPORATION
ELECTRONIC CONTROLS DIVISION

800-447-1204 • 763-241-3238 • fax: 800-447-1258
www.tescom.com • ecd@tescom.com
12616 Industrial Boulevard • Elk River, MN 55330 USA