



Vortex Flow sensor

Flow sensor for liquid media Type 210

The flow sensor type 210 is based on the Kármán vortex trail principle. In comparison to the OEM flow sensor (type 200), the type 210 is available with enhanced power supply and output signals and is available with and without temperature measurement

With no moving parts the flow sensor is not sensitive to debris, has marginal pressure loss and high accuracy.



Flow range

0.5 ... 150 l/min

Nominal diameters

DN 6 / 8 / 10 / 15 / 20 / 25

Temperature measurement

-40 ... +125 °C

- + Flow measuring with voltage, current, pulse or frequency output
- + Temperature non-sensitive measuring principle
- + Excellent media resistance (measuring element not in contact with the media)
- + Wide application temperature range
- + Marginal loss of pressure
- + Measuring element not sensitive to debris
- + Direct temperature measurement in the medium
- + Drinking water approval KTW, W270, ACS, WRAS

Technical overview

Flow measurement

Measuring principle	Vortex		Piezoelectric sensor element
Measuring range			0.5 ... 150 l/min
Nominal diameters			DN 6 / 8 / 10 / 15 / 20 / 25
Accuracy at < 50% fs (water)			< 1% fs
Accuracy at > 50% fs (water)			< 2% measuring value
Response time	Immediately. Therefore suitable for spigot use.	Frequency output (unfiltered)	Signal delay < 100 ms
		Frequency output (filtered)	Response time < 5 ms
		Analogue output	Signal delay < 2 s
			Response time < 500 ms

Operating conditions

Medium	Suitable for heating circuit water with the usual additives Drinking water	Other medium on request
Temperature		Media < +125 °C
		Ambient -15 ... +85 °C
		Ambient (2x 4 ... 20 mA) -15 ... +65 °C
		Storage -30 ... +85 °C
Max. pressure and medium temperature		(for lifetime) 12 bar at +40 °C
		(for lifetime) 6 bar at +100 °C
		(for 600 hours) 4 bar at +125 °C
		(for 2 hours) 4 bar at +140 °C
Cavitation	The following equation is valid to prevent cavitation:	$P_{abs\ outlet} / P_{difference} > 5.5$

Materials in contact with medium (FDA-conform)

Sensor paddle	ETFE
Case with damming body	PAGT/GI (40% GF)
Sealing material	EPDM (perox.) FPM

Electrical connection

Connector M12x1	Protection standard IP 65
-----------------	---------------------------

Weight

DN 6 / 8	~ 47 g
DN 10	~ 57 g
DN 15	~ 68 g
DN 20	~ 92 g
DN 25	~ 100 g

Test / Admissions

Electromagnetic compatibility	CE conformity acc. EN 61326-2-3 WRAS
Drinking water approval	Plastic parts with KTW and W270 approval ACS

Packaging (multiple packaging)

	Connection copper tube	Outside thread K	Outside thread G
DN 6	-	Blister 30x	Blister 30x
DN 8 / 10	Blister 30x	Blister 30x	Blister 30x
DN 15	Blister 30x	Blister 30x	Blister 20x
DN 20	Blister 20x	Blister 20x	Blister 15x
DN 25	-	Blister 20x	Blister 15x

Minimum life span on high flow rate and high temperature

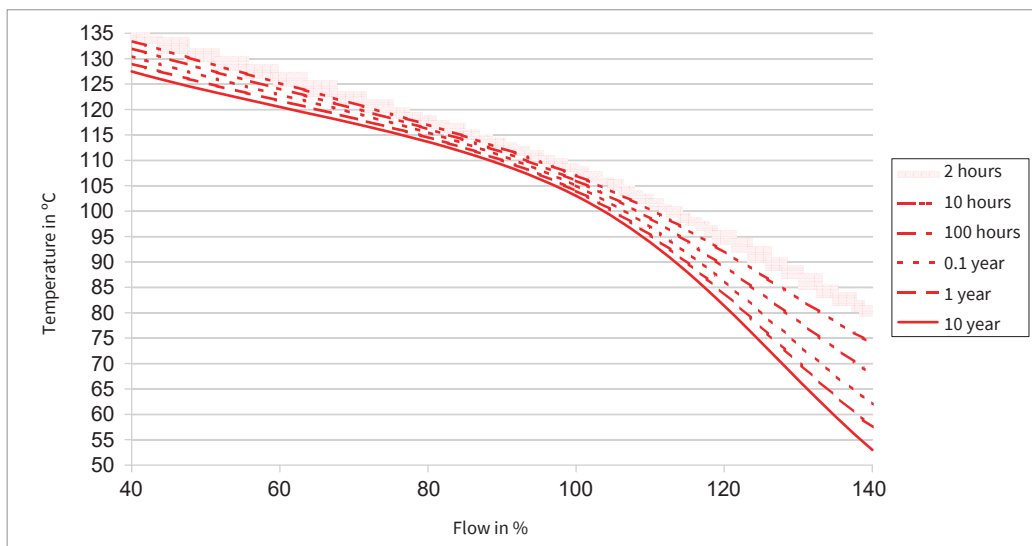

Analogue output - Electrical overview

Temperature measurement (> 8 DN)

Measuring principle	Resistance			PT1000
	Measuring range			-40 ... +125 °C
PT1000	Accuracy	class B DIN EN 60751	@ T = 0 °C	± 0.3 K
			@ T ≠ 0 °C	± 0.3 K ± 0.005 * ΔT
0 ... 10 V	Measuring range			-25 ... +125 °C
	Accuracy			± 0.5 K ± 0.005 * ΔT
	Calculation temperature			T (°C) = ±150 °C 10 V U _{OUT,T} - 25 °C
4 ... 20 mA	Measuring range			-25 ... +125 °C
	Accuracy			± 0.5 K ± 0.005 * ΔT
	Calculation temperature			T (°C) = $\frac{U_{OUT,T} - 4 \text{ mA}}{16 \text{ mA}} * 150 \text{ °C} - 25 \text{ °C}$

Electronic	Voltage output	Current output	Dual power output
Power supply	11.5 ... 33 VDC	8 ... 33 VDC	10 ... 33 VDC
Output flow (Q)	0 ... 10 V	4 ... 20 mA	4 ... 20 mA
Output temperature (T)	0 ... 10 V	-	4 ... 20 mA
Load against GND or IN	< 6 mA / < 100 nF ¹⁾	< (U _{IN} - 8 V) / 20 mA	< (U _{IN} - 10 V) / 20 mA
Current consumption load free (I ₀)	< 5 mA	-	-
Electrical reliability	Short circuit, reverse voltage and external voltage protected within the admissible supply voltage.		

Analogue output - Nominal diameters dependent variables

DN	Measuring range [l/min]	Flow range [m/s]	Pressure drop ^{2),3)}	K _V [$\frac{\text{L}}{\text{V} * \text{min}}$]	K _I [$\frac{\text{L}}{\text{mA} * \text{min}}$]
6	0.5 ... 10	0.074 ... 1.474	240.00*Q ²	1.0	0.625
8	0.9 ... 15	0.133 ... 2.210	85.00*Q ²	1.5	0.938
10	1.8 ... 32	0.265 ... 4.716	22.50*Q ²	3.2	2.000
10	2.0 ... 40	0.295 ... 5.895	22.50*Q ²	4.0	2.500
15	3.5 ... 50	0.290 ... 4.145	6.70*Q ²	5.0	3.125
20	5.0 ... 85	0.265 ... 4.509	2.50*Q ²	8.5	5.313
25	9.0 ... 150	0.283 ... 4.709	0.92*Q ²	15.0	9.375

Characteristic line formula current output

$$Q_V = K_I * (I_{OUT} - 4 \text{ mA})$$

Characteristic line formula voltage output

$$Q_V = K_V * U_{OUT}$$

Legend

Q _V	Volume flow rate	[l/min]
K _V	Coefficient voltage output	[(l/min) / V]
K _I	Coefficient current output	[(l/min) / mA]
U _{OUT}	Voltage	[V]
I _{OUT}	Current	[mA]

Analogue output - Order code selection table

			1	2	3	4	5	6	7
			210.	X	X	X	X	X	X
Version	Flow		9			3,4	4		
	Flow and temperature (PT1000)		8			3,4	5		
	Flow and temperature (2x 0 ... 10 V)		6			3	5		
	Flow and temperature (2x 4 ... 20 mA)		5			5	5		
Nominal diameters and Flow range	DN 6	0.5 ... 10 l/min.	9	0	6				K,G
	DN 8	0.9 ... 15 l/min.		0	8				
	DN 10	1.8 ... 32 l/min.		1	0				
	DN 10	2.0 ... 40 l/min.		1	1				
	DN 15	3.5 ... 50 l/min.		1	5				
	DN 20	5.0 ... 85 l/min.		2	0				
	DN 25	9.0 ... 150 l/min.		2	5				K,G
Output / power supply	Analogue output 0 ... 10 V	11.5 ... 33 VDC	9,8,6			3			
	Analogue output 4 ... 20 mA	8 ... 33 VDC	9,8			4			
	Analogue output 4 ... 20 mA	10 ... 33 VDC	5			5			
Electrical connection	Connector M12x1	3-pole (with condensation protection)	9			3,4	4		
		5-pole (with condensation protection)	8,6,5				5		
Sealing material	EPDM	Ethylene propylene rubber (peroxidically cross-linked)						1	
	FPM ⁴⁾	Fluoro elastomer						2	
Tube connection	Plastic PA6T / 6I	connection copper tube (max. DN 20)							N
		outside thread K (see dimension diagram)							K
		outside thread G (see dimension diagram)							

¹⁾ against GND only

²⁾ incl. 3xDi inlet and outlet side

³⁾ Pv in Pa; Q in l/min

⁴⁾ No drinking water approval

Frequency output (filtered) and pulse output - Electrical overview

Temperature measurement (> 8 DN)

Measuring principle	Resistance	PT1000 class B DIN EN 60751		
	Measuring range	-40 ... +125 °C		
PT1000	Accuracy	Class B DIN EN 60751	@ T = 0 °C @ T ≠ 0 °C	± 0.3 K ± 0.3 K ± 0.005 * ΔT
Temperature influences		Self-heating at temperature sensor		1 K/mW
		Conduction resistance to connector		0.8 Ω

Electronic

Power Supply	4.75 ... 33 VDC		
Output flow (Q)	Level height (open collector)	< 0.5 ... > U _N - 0.5 V	
Output temperature (T)	Resistant signal	PT1000 class B DIN EN 60751	
Load against GND or IN	> 1 kΩ / < 10 kΩ		
Current consumption load free (I ₀)	< 3 mA		
Electrical reliability	Short circuit, reverse voltage and external voltage protected within the admissible supply voltage.		

Frequency output (filtered) and pulse output - Nominal diameters dependent variables

DN	Measuring range [l/min]	Flow range [m/s]	Pressure drop ^{1),2)}	K _{ff} [(l/min) / Hz] at 0 ... 1000 Hz	Quantity per pulse K [ml] (pulse)	Pulse (pulse output) [1/l]
6	0.5 ... 10	0.074 ... 1.474	240.00*Q ²	0.01	0.20	5000
8	0.9 ... 15	0.133 ... 2.210	85.00*Q ²	0.015	0.20	5000
10	1.8 ... 32	0.265 ... 4.716	22.50*Q ²	0.032	0.50	2000
10	2.0 ... 40	0.295 ... 5.895	22.50*Q ²	0.04	0.50	2000
15	3.5 ... 50	0.290 ... 4.145	6.70*Q ²	0.05	1.00	1000
20	5.0 ... 85	0.265 ... 4.509	2.50*Q ²	0.085	1.00	1000
25	9.0 ... 150	0.283 ... 4.709	0.92*Q ²	0.15	1.25	800

Characteristic line formula frequency output filtered (0 ... 1000 Hz, other frequency on request)

$$Q_v = K_{ff} * f$$

Pulse

$$l/min = \frac{pulse}{s} * K_{ff} * \frac{60}{1000}$$

Legend

Q _v	Volume flow rate	[l/min]
K _{ff}	Coefficient frequency output filtered	[(l/min) / f]
f	Frequency	[Hz]

Frequency output (filtered) and pulse output - Order code selection table

210. X X X X X X X

			1	2	3	4	5	6	7
Version	Flow		9				4		
	Flow and temperature (PT1000)		8				5		
Nominal diameters and flow range	DN 6	0.5 ... 10 l/min.	9	0	6				K,G
	DN 8	0.9 ... 15 l/min.		0	8				
	DN 10	1.8 ... 32 l/min.		1	0				
	DN 10	2.0 ... 40 l/min.		1	1				
	DN 15	3.5 ... 50 l/min.		1	5				
	DN 20	5.0 ... 85 l/min.		2	0				
	DN 25	9.0 ... 150 l/min.		2	5				K,G
Output / power supply	Frequency output (filtered)	4.75 ... 33 VDC				6			
	Pulse output	4.75 ... 33 VDC				7			
Electrical connection	Connector M12x1	3-pole (with condensation protection)	9				4		
		5-pole (with condensation protection)	8				5		
Sealing material	EPDM	Ethylene propylene rubber (peroxidically cross-linked)						1	
	FPM ³⁾	Fluoro elastomer						2	
Tube connection	Plastic PA6T / 6I	connection copper tube (max. DN 20)							N
		outside thread K (see dimension diagram)							K
		outside thread G (see dimension diagram)							

¹⁾ incl. 3xDi inlet and outlet side

²⁾ Pv in Pa; Q in l/min

³⁾ No drinking water approval

Frequency output (unfiltered) - Electrical overview

Temperature measurement (> 8 DN)

Measuring principle	Resistance	PT1000 class B DIN EN 60751		
	Measuring range	-40 ... +125 °C		
PT1000	Accuracy	Class B DIN EN 60751	@ T = 0 °C @ T ≠ 0 °C	± 0.3 K ± 0.3 K ± 0.005 * ΔT
Temperature influences		Self-heating at temperature sensor Conduction resistance to connector		1 K/mW 0.8 Ω

Electronic

Power Supply	4.75 ... 33 VDC		
Output flow (Q)	Level height (push-pull)	< 0.5 ... > U _N - 0.5 V	
Output temperature (T)	Resistant signal	PT1000 class B DIN EN 60751	
Load against GND or IN	< 1 mA / < 100 nF		
Current consumption load free (I ₀)	< 2 mA		
Electrical reliability	Short circuit, reverse voltage and external voltage protected within the admissible supply voltage.		

Frequency output (unfiltered) - Nominal diameters dependent variables

DN	Tube connection	Measuring range [l/min]	Flow range [m/s]	Pressure drop ^{1),2)}	Quantity per pulse @50% fs [ml]	Frequency range unfiltered [Hz]	Q ₀ [l/min]	K _f [(l/min) / f]
6	K	0.5 ... 10	0.074 ... 1.474	240.00*Q ²	0.386	27 ... 426	-0.14	0.0238
	G							
8	K	0.9 ... 15	0.133 ... 2.210	85.00*Q ²	0.628	30 ... 384	-0.3	0.0398
	G				0.631	30 ... 388		0.0394
	N				0.614	31 ... 399		0.0383
10	K	1.8 ... 32	0.265 ... 4.716	22.50*Q ²	1.399	24 ... 379	-0.2	0.0850
	G				1.370	24 ... 387		0.0832
	N				1.384	24 ... 383		0.0841
10	K	2.0 ... 40	0.295 ... 5.895	22.50*Q ²	1.403	26 ... 473	-0.2	0.0850
	G				1.373	26 ... 483		0.0832
	N				1.388	26 ... 478		0.0841
15	K	3.5 ... 50	0.290 ... 4.145	6.70*Q ²	3.047	20 ... 272	-0.2	0.1843
	G				3.016	20 ... 275		0.1824
	N				3.077	20 ... 270		0.1861
20	K	5.0 ... 85	0.265 ... 4.509	2.50*Q ²	6.213	14 ... 227	-0.3	0.3754
	G				6.125	14 ... 230		0.3701
	N				6.208	14 ... 227		0.3751
25	K	9.0 ... 150	0.283 ... 4.709	0.92*Q ²	12.412	12 ... 201	-0.2	0.7467
	G				12.251	12 ... 204		0.7370

Characteristic line formula frequency output unfiltered

$$Q_v = K_f * f + Q_0$$

Formula quantity per pulse [litres/pulse]

$$\text{Quantity per Pulse} = \frac{K_f * Q_v}{60 * (Q_v - Q_0)}$$

Legend

Q _v	Volume flow rate	[l/min]
Q ₀	Axis intercept	[l/min]
K _f	Coefficient frequency output	[(l/min) / f]
f	Frequency	[Hz]
Quantity per Pulse	Quantity per pulse	litres pulse

		1	2	3	4	5	6	7
Version	Flow	9				4		
	Flow and temperature (PT1000)	8				5		
Nominal diameters and flow range	DN 6	9	0	6				K,G
	DN 8		0	8				
	DN 10		1	0				
	DN 10		1	1				
	DN 15		1	5				
	DN 20		2	0				
	DN 25		2	5				K,G
Output / power supply	Frequency output (unfiltered)				2			
Electrical connection	Connector M12x1	9				4		
		8				5		
Sealing material	EPDM						1	
	FPM ³⁾						2	
Tube connection	Plastic PA6T / 6I							N
								K
								G

¹⁾ incl. 3xDi inlet and outlet side

²⁾ Pv in Pa; Q in l/min

³⁾ No drinking water approval

Accessories (supplied loose)				Order number
Connection kit ¹⁾ DN 8, 10 with copper tube				113775
Connection kit ¹⁾ DN 8, 10 with adapter Rp 3/8 Stainless steel 1.4305/AISI 303				113776
Connection kit ¹⁾ DN 15 with copper tube				113777
Connection kit ¹⁾ DN 15 with adapter Rp 1/2 Stainless steel 1.4305/AISI 303				113778
Connection kit ¹⁾ DN 20 with copper tube				113779
Connection kit ¹⁾ DN 20 with adapter Rp 3/4 Stainless steel 1.4305/AISI 303				113780
Straight-wire box for connector M12x1 with cable		3-pole	200 cm	114605
Corner-wire box for connector M12x1 with cable		3-pole	200 cm	114604
Straight-wire box for connector M12x1 with cable		5-pole	200 cm (with temperature)	114564
Corner-wire box for connector M12x1 with cable		5-pole	200 cm (with temperature)	114563
Straight-wire box for connector M12x1 screwing terminal		5-pole		115024
Clip for DN 8,10				112116
Clip for DN 15				110941
Clip for DN 20				112122
O-Ring for DN 8, DN 10	EPDM	ø 13.95 x 2.62	Copper tube and adapter	112124
O-Ring for DN 15	EPDM	ø 17.86 x 2.62	Copper tube and adapter	112265
O-Ring for DN 20	EPDM	ø 21.89 x 2.62	Copper tube and adapter	112723
O-Ring for DN 25	EPDM	ø 31 x 3	(as a replacement, already assembled)	112792
Connection copper tube for DN 8, 10		L=150 mm		112121
Connection copper tube for DN 15		L=150 mm		112211
Connection copper tube for DN 20		L=150 mm		112306
Adapter for DN 8 und DN 10		Rp 3/8	Stainless steel 1.4305/AISI 303	112655
Adapter for DN 15		Rp 1/2	Stainless steel 1.4305/AISI 303	112660
Adapter for DN 20		Rp 3/4	Stainless steel 1.4305/AISI 303	112661

Tube mounting instructions

Consider the following to ensure the correct function of the sensor.

- Only diameter changes from large to small are allowed.
- Avoid repeated elbows in the same level at entry side

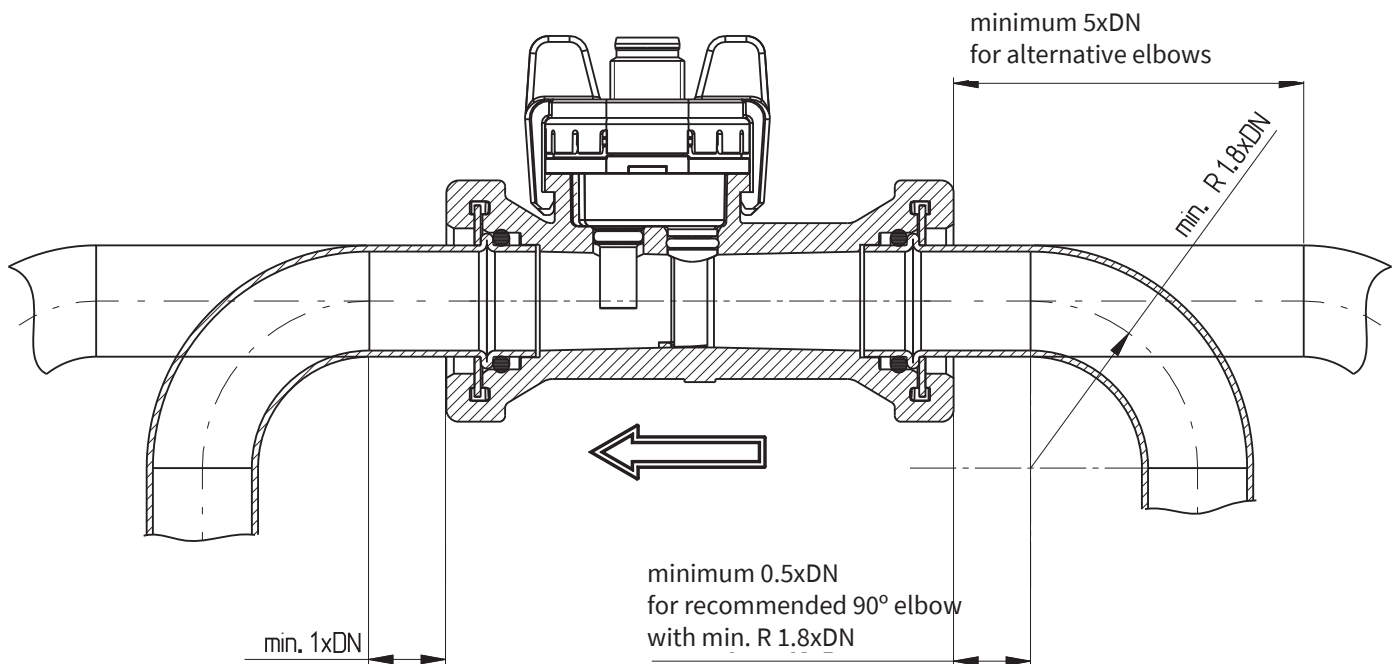

¹⁾ Connection set includes: 2x Clip, 2x Copper tubes or Adapter and 2x O-Ring

Dimension diagram DN 6, 8, 10, 15, 20, 25

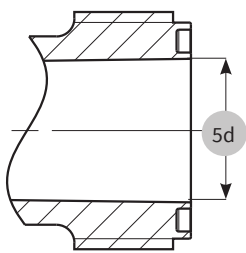
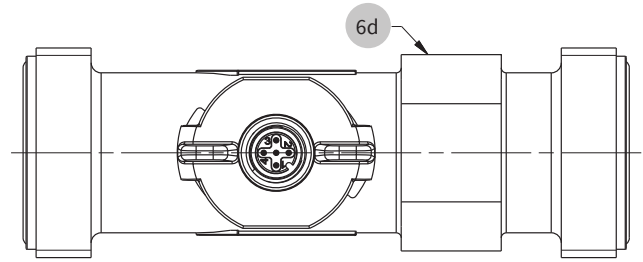
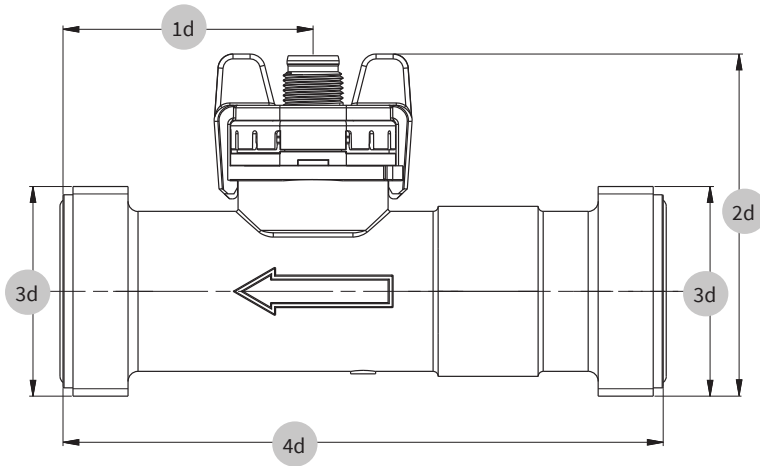

		1d	2d	3d	4d	5d	6d
DN6	K	43.7	53.0	G 1/2	77	11.5	12
DN6	G	48.2	55.7	G 3/4	86	11.5	12
DN8	K	43.7	53.0	G 1/2	77	11.5	12
DN8	G	48.2	55.7	G 3/4	86	11.5	12
DN10	K	35.0	51.3	G 1/2	81	11.5	19
DN10	G	39.5	54.1	G 3/4	90	11.5	19
DN15	K	36.6	56.1	G 3/4	87	16	22
DN15	G	41.6	59.5	G 1	97	16	22
DN20	K	36.6	61.5	G 1	105	20	27
DN20	G	42.6	65.8	G 1 1/4	117	20	27
DN25	K	50.0	68.3	G 1 1/4	120	26	34
DN25	G	56.0	71.3	G 1 1/2	132	26	34

Dimension diagram DN 8, 10, 15, 20

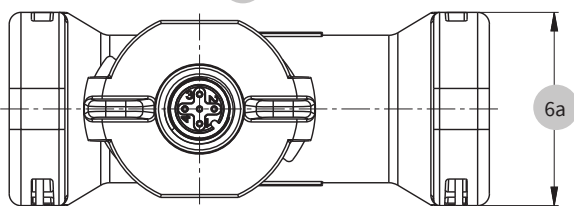
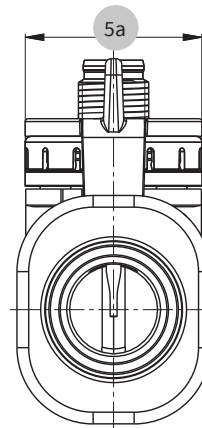
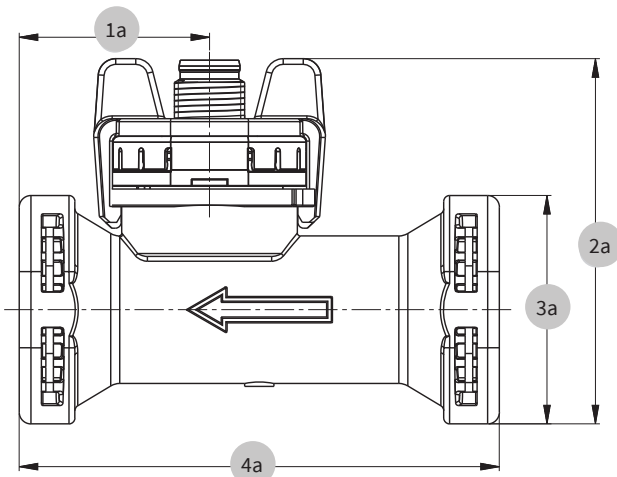

	1a	2a	3a	4a	5a	6a
DN8	29.5	59.0	32.9	72	30.2	28.9
DN10	32.5	57.3	32.9	77	30.2	28.9
DN15	32.5	62.4	39.0	82	30.2	33.0
DN20	39.3	66.3	43.0	105	30.2	37.4

Admissible locking torque

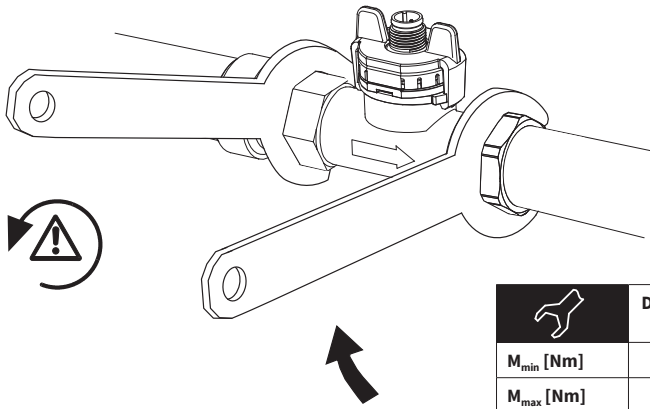

	DN6/8/10 G ½	DN6/8/10 G ¾	DN15 G ¾	DN15 G1	DN20 G1	DN20 G1 ¼	DN25 G1 ¼	DN25 G1 ½
M_{min} [Nm]	1	1	1	2	2	2.5	2.5	2.5
M_{max} [Nm]	12	12	12	12	12	15	15	15

Accessories DN 8, 10, 15, 20

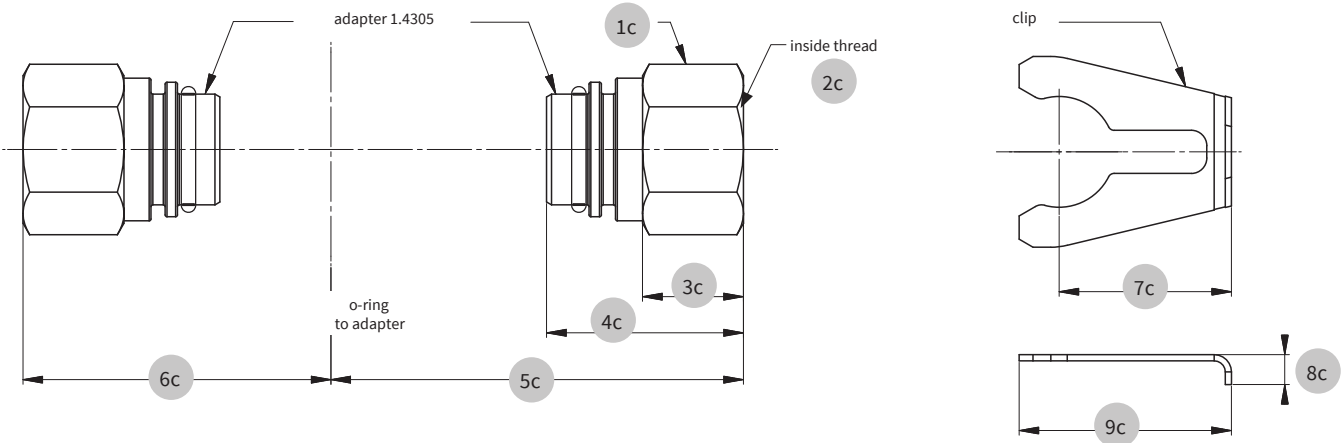

	1c	2c	3c	4c	5c	6c	7c	8c	9c
DN8	22	Rp ¾ DIN 2999 length min. 9	14.0	29	57.65	44.65	24.5	7.3	30.8
DN10	22	Rp ¾ DIN 2999 length min. 9	14.0	29	59.65	47.55	24.5	7.3	30.8
DN15	24	Rp ½ DIN 2999 length min. 11.5	16.4	32	67.05	50.05	28.0	7.6	34.5
DN20	30	Rp ¾ DIN 2999 length min. 13	18.5	38	82.25	58.85	28.0	8.7	34.5

Geometry of customers connection tube DN 8, 10, 15, 20

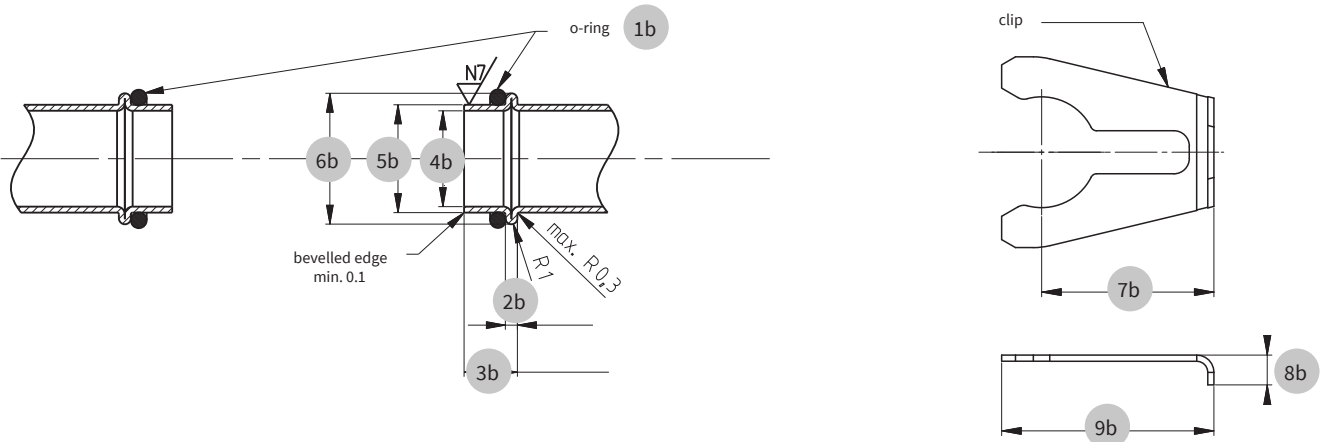

	1b	2b	3b	4b	5b	6b	7b	8b	9b
DN8	ø 13.95x2.62	2 ± 0.2	8.9 ± 0.2	ø 13 ± 0.2	ø 15.00 ± 0.08	ø 18.88 ± 0.1	24.5	7.3	30.8
DN10	ø 13.95x2.62	2 ± 0.2	8.9 ± 0.2	ø 13 ± 0.2	ø 15.00 ± 0.08	ø 18.88 ± 0.1	24.5	7.3	30.8
DN15	ø 17.86x2.62	2 ± 0.2	8.9 ± 0.3	ø 16 ± 0.2	ø 18.00 ^{+0.08} _{-0.06}	ø 21.85 ± 0.1	28.0	7.6	34.5
DN20	ø 21.89x2.62	2 ± 0.2	12.9 ± 0.3	ø 20 ± 0.2	ø 22.00 ^{+0.08} _{-0.06}	ø 25.85 ± 0.1	28.0	8.7	34.5

Electrical connection

Connector M12x1 without temperature measurement

1

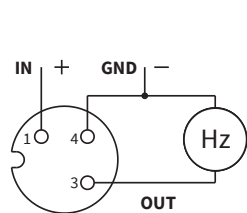

Frequency output unfiltered

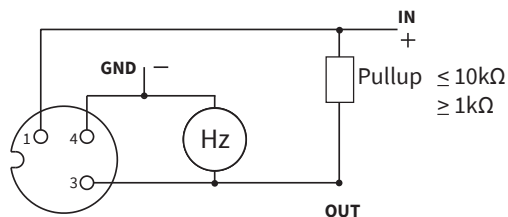

Frequency output filtered Pulse output

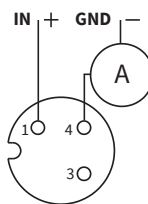

Current output

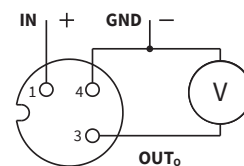

Voltage output

Connector M12x1 with temperature measurement

2

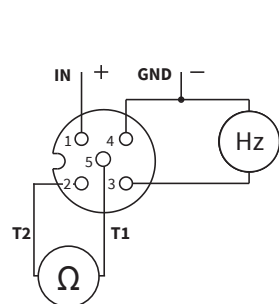

frequency output with temperature measurement PT1000

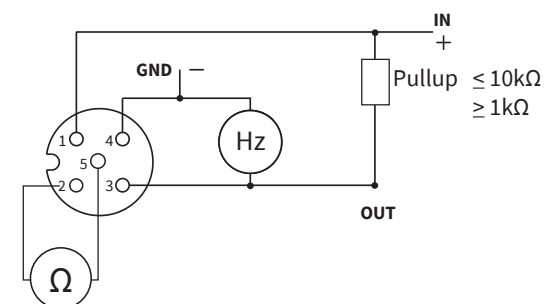

Frequency output filtered Pulse output

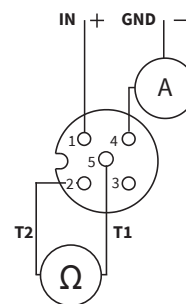

Current output with temperature measurement PT1000

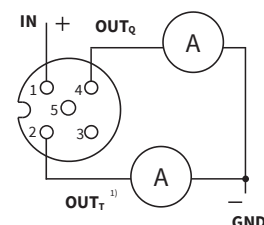

Current output with temperature measurement 4 ... 20 mA

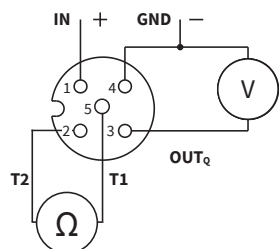

Voltage output with temperature measurement PT1000

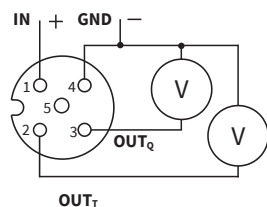

Voltage output with temperature measurement 0 ...10 V

Pin	Colour
1	brown
3	blue
4	black
1	brown
2	white
3	blue
4	black
5	gray

¹⁾ «OUT T» is only in operation if «OUT Q» is connected

Influence of glycol

With the following definitions we are able to correct the influence of media with higher viscosity than water (= media viscosity > 1.8 cSt) in order to reach a measuring accuracy of 3% fs in the range of 1.8 - 4 cSt and of 4% in the range of 4 - 14 cSt (viscosity in cSt).

Definition of viscosity of glycol-water-compound

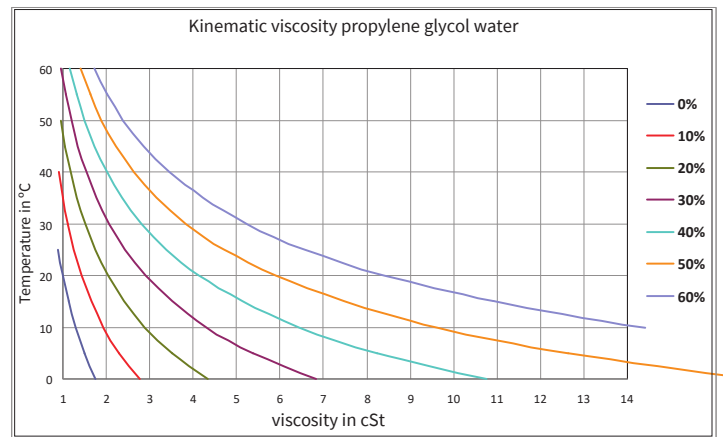
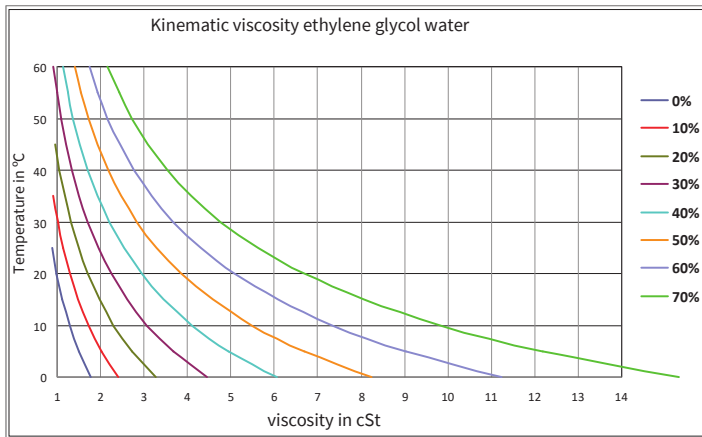

Definition of response threshold Q_{min}

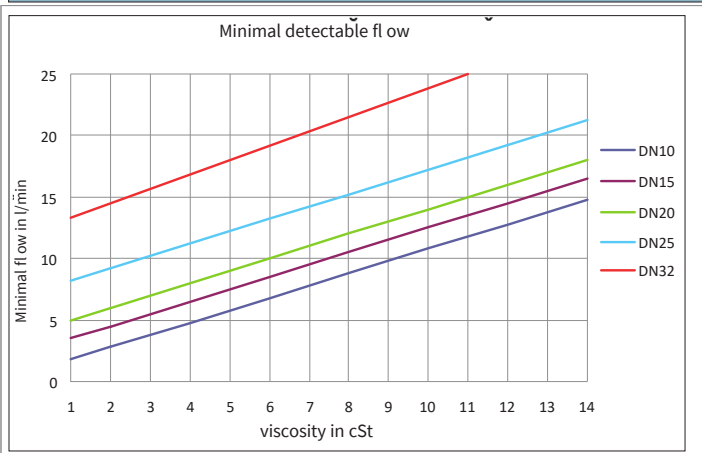

Definition of characteristic line formula $Q = K_f * f + Q$

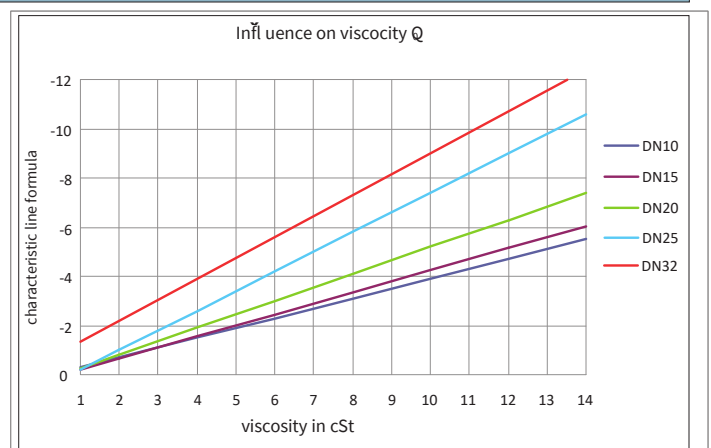

Formula response threshold Q_{min} in l/min

< DN 10 not possible

- DN10: $Q_{min} = u + 0.8$
- DN15: $Q_{min} = u + 2.5$
- DN20: $Q_{min} = u + 4$
- DN25: $Q_{min} = u + 8$

Formula characteristic line for $Q > Q_{in}$ in l/min

< DN 10 not possible

Frequency output (unfiltered):

- DN10: $Q = K_f * f - 0.40u + 0.20$
- DN15: $Q = K_f * f - 0.45u + 0.25$
- DN20: $Q = K_f * f - 0.55u + 0.25$
- DN25: $Q = K_f * f - 0.80u + 0.60$

Frequency output (filtered):

- DN10: $Q = 0.032 * f - 0.40u + 0.40$
- DN15: $Q = 0.050 * f - 0.45u + 0.45$
- DN20: $Q = 0.080 * f - 0.55u + 0.55$
- DN25: $Q = 0.150 * f - 0.80u + 0.80$

Impulse output:

- DN10: $Q = 0.030 * \#Pulse/s - 0.40u + 0.40$
- DN15: $Q = 0.060 * \#Pulse/s - 0.45u + 0.45$
- DN20: $Q = 0.060 * \#Pulse/s - 0.55u + 0.55$
- DN25: $Q = 0.075 * \#Pulse/s - 0.80u + 0.80$

Voltage output 0...10 V:

- DN10: $Q = 3.2 * U_{out} - 0.40u + 0.40$
- DN15: $Q = 5.0 * U_{out} - 0.45u + 0.45$
- DN20: $Q = 8.5 * U_{out} - 0.55u + 0.55$
- DN25: $Q = 15.0 * U_{out} - 0.80u + 0.80$

Current output 4...20 mA (I in mA):

- DN10: $Q = 2.000 * (I - 4 \text{ mA}) - 0.40u + 0.40$
- DN15: $Q = 3.125 * (I - 4 \text{ mA}) - 0.45u + 0.45$
- DN20: $Q = 5.313 * (I - 4 \text{ mA}) - 0.55u + 0.55$
- DN25: $Q = 9.375 * (I - 4 \text{ mA}) - 0.80u + 0.80$



www.fluidprocessing.it 

Via Mimmi Fochi 36
43058 Sorbolo (PR) Italy
Ph: +39 0521 690655
info@fluidprocessing.it

