

PRESSURE REDUCING VALVES **MANKENBERG** INDUSTRIEARMATUREN

for liquids and gases
up to 130 °C

Type 662

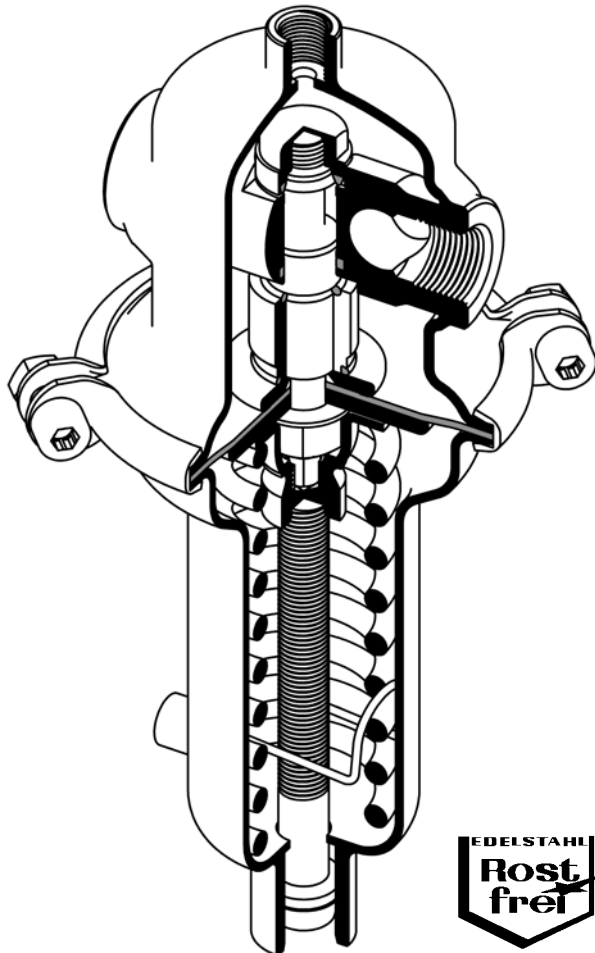

TECHNICAL DATA

MEDIUM	liquids, gases
NOMINAL PRESSURE	PN 100/16, /10, /6, /2,5, /1
CONNECTION	G 1/2 - 1, DN 15 - 25
INLET PRESSURE	up to 100 bar
OUTLET PRESSURE	0,02 - 12 bar in 7 ranges
TEMPERATURE	up to 130 °C
KVS-VALUE	3,2 - 3,6 m ³ /h

DESCRIPTION

Pressure reducing valves control the pressure at the outlet side.

The pressure reducer type 662 is a diaphragm-controlled, spring-loaded proportional controller with release. All parts consist of Cr-Ni-Mo steel with smooth surfaces. Setting screw and spring are integrated so that altering the pressure setting does not change the height of the unit. The sealing is equal to or better than VDI/VDE rule 2174.

With depressurized pipeline the spring keeps the valve cone in open position. Under pressure the medium flows from the inlet side through the valve seat into the body and acts on the diaphragm /spring system from the outlet side (outlet pressure).

The outlet pressure balances the force of the valve spring across the diaphragm (set value). As the outlet pressure rises above the pressure set using the setting screw, the valve cone moves toward the seat causing the flow to be restricted. As the outlet pressure drops the restricting orifice becomes larger. The valve is fully open if the pipeline is depressurized. Rotating the setting screw clockwise increases the outlet pressure.

The maximum permitted outlet pressure is 1,5 times the set pressure, unless otherwise specified.

If toxic or hazardous media are used the valve must feature a sealed spring cover (including setting spindle seal) fitted with a leakage line connection. When the overflow valve is installed on site a leakage line must be fitted capable of safely draining the escaping medium in case the control valve should become defective.

With outlet pressure ≤ 1.1 bar a sense line has to be installed.

Mankenberg reserves the right, to alter or improve the designs or specifications of the products described herein without notice.

Special designs on request.

KVS-VALUES				
Nominal diameter	DN	15	20	25
	G	1/2	3/4	1
Kvs-value	m ³ /h	3,2	3,5	3,6

ADJUSTING RANGES [bar], NOMINAL PRESSURE [PN]				
adjusting range	6 - 12	4 - 8	2 - 5	0,8 - 2,5
nominal pressure	100/16	100/16	100/10	100/6

ADJUSTING RANGES [bar], NOMINAL PRESSURE [PN]			
adjusting range	0,3 - 1,1	0,1 - 0,5	0,02 - 0,12
nominal pressure	100/2,5	100/1	100/1

PRESSURE REDUCING VALVES

MANKENBERG
INDUSTRIEARMATUREN

for liquids and gases
up to 130 °C

Type 662

MATERIALS	
TEMPERATURE	max. 130 °C
BODY	CrNiMo-steel
SPRING CAP	
INNER PARTS	
SCREWS	
SET SCREW	
VALVE SEAL	EPDM (standard) / FPM / PTFE
SPRING	CrNi-steel
DIAPHRAGM	EPDM (standard) / FPM
PROTECTION FILM	PTFE (if needed)

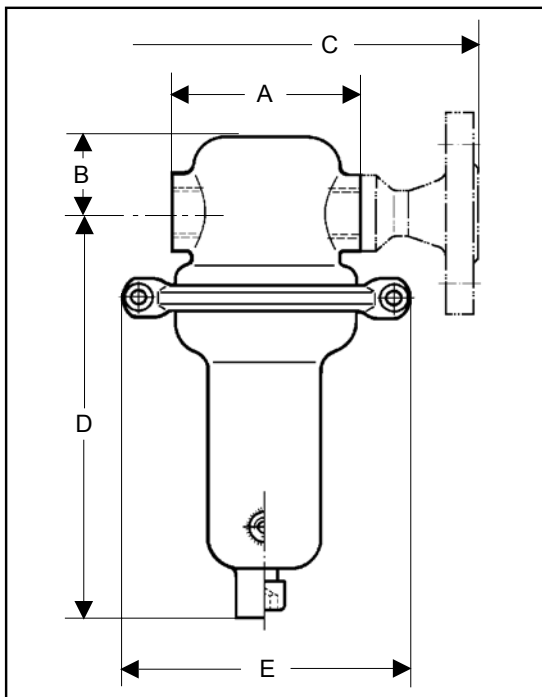

DIMENSIONS [mm] and WEIGHTS [kg]					
pressure ranges	size	nominal diameter		weights	
		G 1/2 - 3/4 DN 15 - 20	G 1 DN 25	G 1/2 - 3/4 kg	DN 15 - 25 kg
all ranges	A	90	136		
	B	40			
0,02 - 0,12 *	C	200		13	14
	D	270			
	øE	360			
0,1 - 0,5 *	C	200		6,5	7,5
	D	270			
	E	264 / 210			
0,3 - 1,1 *	C	200		5,5	6,5
	D	270			
	E	200 / 155			
0,8 - 12	C	200		2,5	3,5
	D	205			
	E	138 / 110			

* with control line connection

RECOMMENDED INSTALLATION

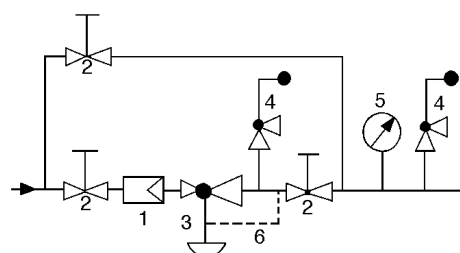

sense line connection right hand side from inlet, 10 -20 x DN before the valve

- 1 strainer*
- 2 shutoff valves
- 3 pressure reducer*
- 4 safety valves*
- 5 pressure gauge*
- 6 sense line G 3/8
only with pressure ranges $\leq 1,1$ bar

* use MANKENBERG-products

Mankenberg reserves the right, to alter or improve the designs or specifications of the products described herein without notice.
Special designs on request.

Sheet no. DM 662/3.1.031.1 - Issue 12.06.2003