

Slip Ring Capsule SC 012

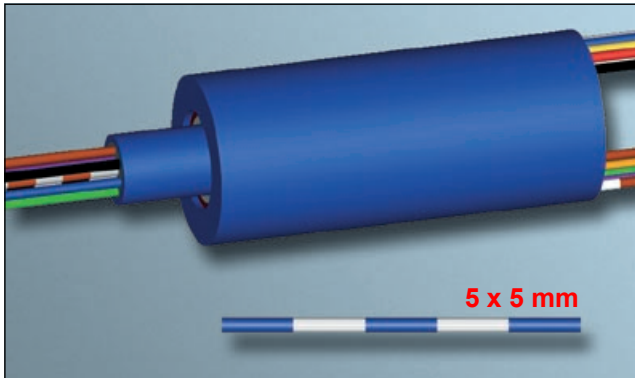

- 6 or 12 rings with max. 2 A per ring
- max. 120 V
- Outer diameter 12 mm

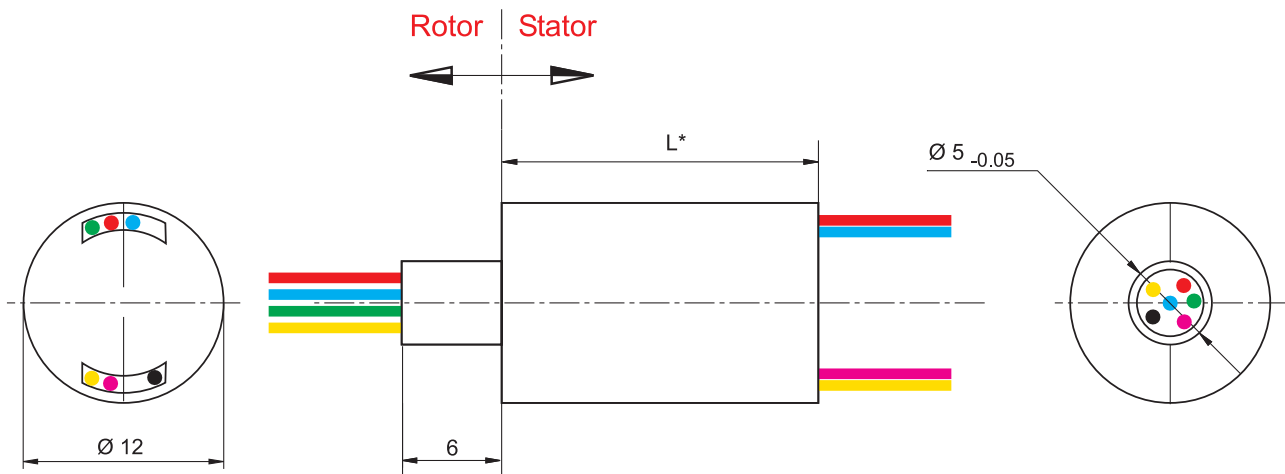

Electrical Data

Number of rings:	6 or 12 rings
Current:	2 A max. per ring
Voltage:	120 V DC max.
High pot:	500 V AC
Insulation resistance:	1000 MOhm at 500 V DC
Noise:	20 mOhm at 5 rpm, 6 V DC and 50 mA
Contacts / Leads:	Gold-gold / silver plated copper with teflon insulation

Number of rings	L^* (mm)
6	19
12	28

Mechanical Data

Speed:	250 rpm max.
Protection class:	IP 40
Temperature:	-20 °C ... +80 °C (-5 °F ... +175 °F)
Rotor connection:	300 mm leads; AWG 28/19 (0,1 mm ²)
Stator connection:	300 mm leads; AWG 28/19 (0,1 mm ²)
Bearings:	sealed miniature ball bearings of steel
Housing:	made of glass fibre reinforced polycarbonate
Secure:	body to be clamped or glued; flange optional

LTN Servotechnik GmbH

Operating Principle

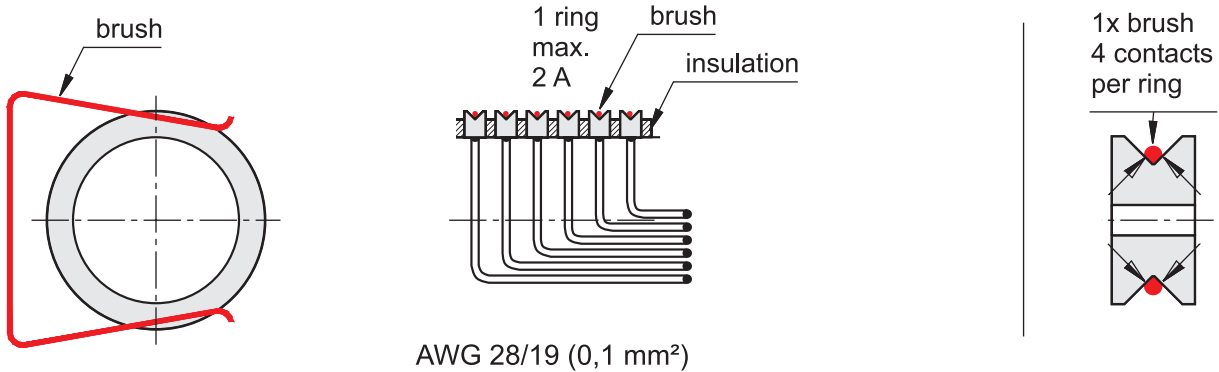

Order Information

- No. of rings: 6 or 12
- Options as below

Options

- Flange with 3 bores dia. 3.3 mm on b.c.d. of 18.5 mm
- Different axial flange position upon request
- 14 rings upon request
- Length of leads more than 300 mm upon request
- Flat ribbon cable upon request

Number of rings	L* (mm)
6	19
12	28

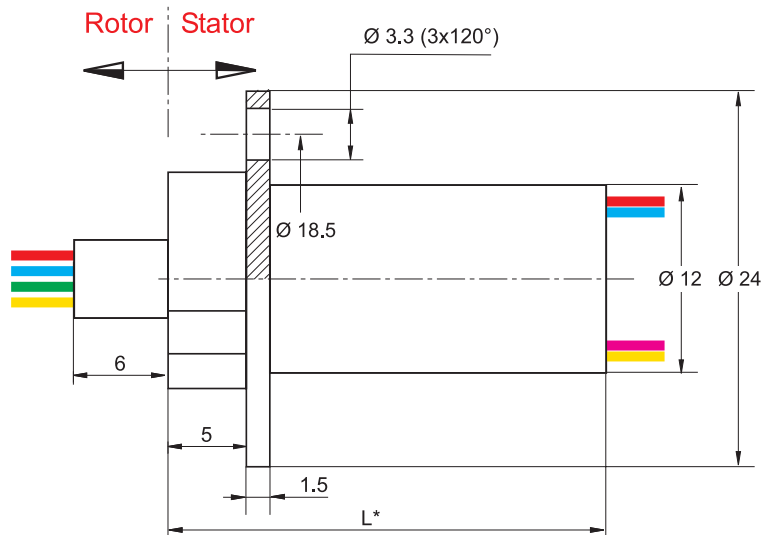
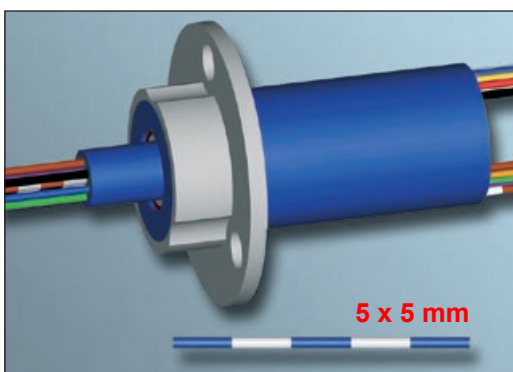

LTN Servotechnik GmbH

Georg-Hardt-Straße 4
D-83624 Otterfing
Germany

Tel: +49 - (0)8024-6080-0

Fax: +49 - (0)8024-6080-100

E-Mail: LTN@LTN.de

Internet: www.LTN.de