

Rosemount 8721 Sanitary Magmeter Flowtube

THE 8721 SANITARY FLOWTUBE:

- *Designed for food, beverage, and pharmaceutical applications*
- *Stainless steel, all welded body*
- *Available with a variety of process connections*
- *Suitable for CIP/SIP*
- *Flowtube Inside Diameter (ID) matches sanitary process pipe ID with no steps*



Content

Rosemount 8721 Sanitary Flowtube Specifications	page 3
Product Certifications	page 5
Dimensional Drawing	page 6
Magnetic Flowmeter Sizing	page 9
Material Selection	page 11
Ordering Information	page 12

Rosemount 8721

The Rosemount 8721 Sanitary Magmeter Flowtube Delivers Reliability, Stability, and Performance

OPERATION

The operating principle of the magnetic flowmeter system is based upon Faraday's Law of electromagnetic induction, which states that a *voltage will be induced in a conductor moving through a magnetic field.*

Faraday's Law: $E=kBDV$

The magnitude of the induced voltage **E** is directly proportional to the velocity of the conductor **V**, conductor width **D**, and the strength of the magnetic field **B**. The figure below of a Rosemount 8705 flowtube illustrates the relationship between the physical components of the magnetic flowmeter and Faraday's Law.

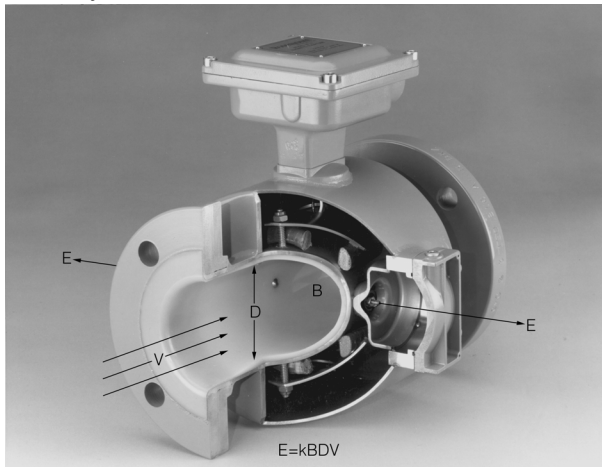

This product is a core component of the PlantWeb digital plant architecture.

Magnetic field coils placed on opposite sides of the pipe generate a magnetic field. As the conductive process liquid moves through the field with average velocity **V**, electrodes sense the induced voltage. The width of the conductor is represented by the distance between electrodes. An insulating liner prevents the signal from shorting to the pipe wall.

The only variable in this application of Faraday's Law is the velocity of the conductive liquid **V** because field strength is controlled constant and electrode spacing is fixed. Therefore, the output voltage **E** is directly proportional to liquid velocity, resulting in the inherently linear output of a Rosemount Magnetic Flowmeter.

Rosemount 8721

The Rosemount 8721 Sanitary Magnetic Flowtube is specifically designed for food, beverage, and pharmaceutical applications. The product contact surfaces are constructed of materials conforming to FDA requirements materials and are designed in accordance with 3-A standards. The flowtube is CIP/SIP cleanable and the flowtube I.D matches the process piping to allow the flowtube to be pigged with the process piping. The 8721 is available with a variety of standard sanitary process connections and is easily adapted for other process conditions. The all stainless steel meter body is fully welded. Critical junctures are potted to provide a hermetic seal, protecting the internal components and wiring from pressurized steam, water, and sanitation chemicals.

- Conforms to 3-A sanitary standards and authorized to display 3-A symbol.
- European Hygienic Equipment Design Group (EHEDG) Type EL Certified.

Rosemount 8721 Sanitary Flowtube Specifications

NOTE

All transmitter specifications can be found in the Product Data Sheet 00813-0100-4727.

Functional Specifications

Service

Conductive liquids and slurries

Line Sizes

¹/₂ -4 inch (15–100 mm)

Flowtube Compatibility and Interchangeability

The Rosemount 8721 Flowtubes are interchangeable with Rosemount 8732, 8742, and 8712D transmitters. System accuracy is maintained regardless of line size or optional features.

Each flowtube nameplate has a sixteen-digit calibration number that can be entered into the transmitter through the Local Operator Interface (LOI) or the HART Communicator. No further calibration is necessary.

Flowtube Compensation

Rosemount flowtubes are flow-calibrated and assigned a calibration factor at the factory. The calibration factor is entered into the transmitter, enabling interchangeability of flowtubes without calculations or a compromise in accuracy.

Conductivity Limits

Process liquid must have a conductivity of 5 microsiemens/cm (5 micromhos/cm) or greater. Excludes the effect of interconnecting cable length in remote mount transmitter installations.

Flowtube Coil Resistance

5Ω to 10Ω (line size dependant)

Flow Rate Range

Capable of processing signals from fluids that are traveling between 0.04 and 33 ft/s (0.01 to 10 m/s) for both forward and reverse flow in all flowtube sizes. Full scale continuously adjustable between -33 and 33 ft/s (-10 to 10 m/s).

Flowtube Ambient Temperature Limits

14 to 140 °F (-15 to 60 °C)

Process Temperature Limits

PFA Lining

14 to 320°F (-10 to 160 °C)

Pressure Limits

Line Size	Max Working Pressure	CE Mark Max. Working Pressure
¹ / ₂ (15)	300 psi (20.7 bar)	300 psi (20.7 bar)
1 (25)	300 psi (20.7 bar)	300 psi (20.7 bar)
1 ¹ / ₂ (40)	300 psi (20.7 bar)	300 psi (20.7 bar)
2 (50)	300 psi (20.7 bar)	300 psi (20.7 bar)
2 ¹ / ₂ (65)	300 psi (20.7 bar)	240 psi (16.5 bar)
3 (80)	300 psi (20.7 bar)	198 psi (13.7 bar)
4 (100)	210 psi (14.5 bar)	148 psi (10.2 bar)

Vacuum Limits

Full vacuum at maximum lining material temperature; consult factory.

Submergence Protection (Flowtube)

IP68. Continuous to 30 ft (10 m).

Performance Specifications

(System specifications are given using the frequency output and with the unit at referenced conditions).

Accuracy

Rosemount 8732, 8742, or 8712D with 8721 Flowtube

System accuracy is ±0.5% of rate from 1 to 30 ft/s (0.3 to 10 m/s); includes combined effects of linearity, hysteresis, repeatability, and calibration uncertainty; between 0.04 and 1.0 ft/s (0.01 and 0.5 m/s), the system has an accuracy of ±0.005 ft/s. Analog output has the same accuracy as frequency output plus an additional 0.1% of span.

Repeatability

±0.1% of reading

Response Time

0.2 seconds maximum response to step change in input

Stability

±0.1% of rate over six months

Ambient Temperature Effect

±1% per 100 °F (37.8 °C)

Mounting Position Effect

None when installed to ensure flowtube remains full.

Physical Specifications

Mounting

Integrally mounted transmitters are factory-wired and do not require interconnecting cables. The transmitter can rotate in 90° increments. Remote mounted transmitters require only a single conduit connection to the flowtube.

Cable Requirements for Remote Transmitters

TABLE 1. Transmitter Input Power

Description	P/N
Signal Cable (20 AWG) Belden 8762, Alpha 2411 equivalent	08712-0061-0001
Coil Drive Cable (14 AWG) Belden 8720, Alpha 2442 equivalent	08712-0060-0001
Combination Signal and Coil Drive Cable	08712-0752-0001

Remote transmitter installations require equal lengths of signal and coil drive cables. Lengths from 5 to 1,000 feet (1.5 to 300 meters) may be specified, and will be shipped with the flowtube. When ordering the combination cable, the lengths specified must be from 5 to 500 feet (1.5 to 150 meters). For optimum performance, separate signal and coil cables are recommended.

Non-Wetted Materials (Flowtube)

Flowtube

304 Stainless Steel (wrapper), 304 Stainless Steel (pipe)

Terminal Junction Box

Cast aluminum, polyurethane coated

Optional: 304 Stainless Steel

Paint

Polyurethane

Process Wetted Materials (Flowtube)

Liner

PFA with Ra < 32µinch (0.81µm)

Electrodes

316L SST with Ra < 15µinch (0.38µm)

Hastelloy C-276 with Ra < 15µinch (0.38µm)

90% Platinum-10% Iridium with Ra < 15µinch (0.38µm)

Process Connections

The Rosemount 8721 Sanitary Flowtube is designed using a standard IDF fitting as the basis for providing a flexible, hygienic interface for a variety of process connections. The Rosemount 8721 Flowtube has the threaded or "male" end of the IDF fitting on the ends of the base flowtube. The flowtube can be directly connected with user supplied IDF fittings and gaskets. If other process connections are needed, the IDF fittings and gaskets can be provided and welded directly into the sanitary process tubing, or can be supplied with adapters to standard Tri-Clamp® process connections.

Tri-Clamp® Sanitary Coupling

IDF Sanitary Coupling (screw type)

IDF specification per BS4825 part 4

Weld Nipple

DIN 11851

DIN 11864

Process Connection Material

316L Stainless Steel with Ra < 32µinch (0.81µm)

Optional Electropolished Surface Finish with Ra < 15µinch (0.38µm)

Process Connection Gasket Material

Silicone

EPDM

Viton

Buna-N

Electrical Connections (Flowtube)

Two 3/4-14 NPT connections with number 8 screw terminals are provided in the terminal enclosure for electrical wiring.

Flowtube Dimensions

Refer to Figure 1

Product Certifications

Ordinary Location Certification for Factory Mutual

As standard, the transmitter has been examined, tested, and approved to meet basic electrical, mechanical, and fire protection requirements by FM, a nationally recognized testing laboratory (NRTL) as accredited by the Federal Occupational Safety and Health Administration (OSHA).

Certificate Number: 3015960

Canadian Standards Association (CSA) Approvals

Certificate Number: 1428285

Class 2252 03 - Process Control Equipment

Rated 0.5A dc, 60°C

NO Factory Mutual (FM) Ordinary Location; Canadian Standards Association (CSA) Ordinary Location; CE Marking; 3-A Symbol Authorization #1222; EHEDG Type EL

Dimensional Drawing

FIGURE 1. Dimensional Drawings of Rosemount 8721 Flowtubes Typical of 1 through 4inch (25 through 100mm) line sizes.

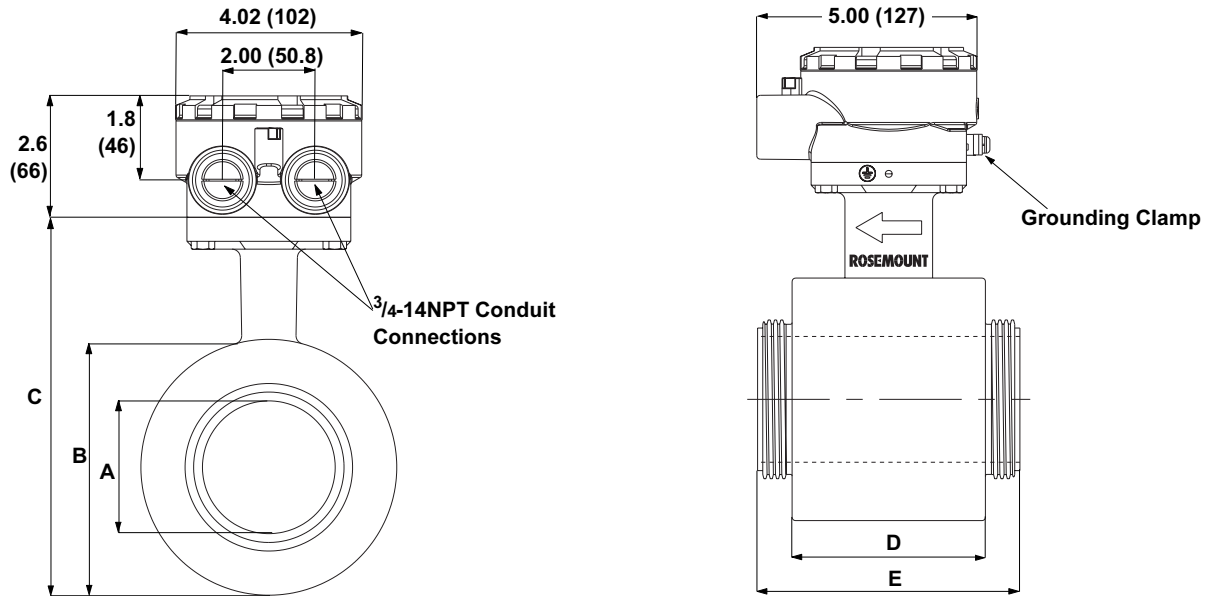

8721_A_01.EPS; 8721_A_02.EPS

TABLE 2. Rosemount 8721 Dimensions in Inches (Millimeters). Refer to Dimensional Drawing Figure 1.

Line Size	Flowtube Dimensions A	Body Diameter B	Flowtube Height C	Body Length D	IDF Length E
1/2 (15)	0.62 (15.8)	2.87 (73.0)	5.51 (140.0)	2.13 (54.0)	3.60 (91.5)
1 (25)	0.87 (22.2)	2.87 (73.0)	5.51 (140.0)	2.13 (54.0)	3.66 (93.0)
1 1/2 (40)	1.37 (34.9)	3.50 (88.9)	6.14 (155.9)	2.40 (61.0)	3.96 (100.5)
2 (50)	1.87 (47.6)	4.00 (101.5)	6.63 (168.5)	2.83 (72.0)	4.41 (112.0)
2 1/2 (65)	2.38 (60.3)	4.53 (115.0)	7.17 (182.0)	3.58 (91.0)	5.23 (133.0)
3 (80)	2.87 (73.0)	5.57 (141.5)	8.21 (208.5)	4.41 (112.0)	5.98 (152.0)
4 (100)	3.84 (97.6)	6.98 (177.0)	9.61 (244.0)	5.20 (132.0)	6.77 (172.0)

FIGURE 2. Dimensional Drawings of Rosemount 8721 Flowtubes Typical of 1 through 4inch (25 through 100mm) line sizes

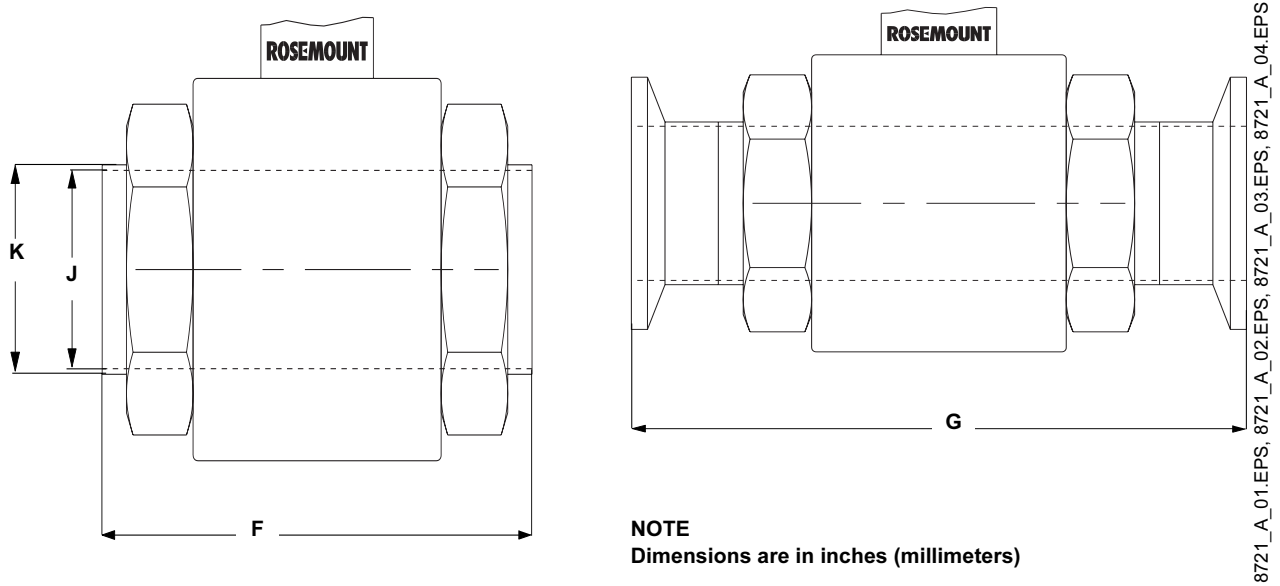

NOTE
 Dimensions are in inches (millimeters)

TABLE 3. Rosemount 8721 Process Connection Lay Length in Inches (Millimeters). Refer to Figure 2.

Line Size	Weld Nipple Length F	Weld Nipple Tube ID J	Weld Nipple Tube OD K	Tri Clamp Length G	Tri Clamp HP Option Length G	Tri Clamp DIN 11851 Length G	Tri Clamp DIN 11864-1 Length G	Tri Clamp DIN 11864-2 Length G
1/2 (15)	5.35 (136.0)	0.62 (15.75)	0.75 (19.05)	8.29 (210.5)	NA	8.33 (211.5)	NA	NA
1 (25)	5.30 (134.5)	0.87 (22.2)	1.00 (25.65)	7.84 (199.2)	9.85 (250.0)	7.87 (200.0)	8.98 (228.0)	8.86 (225.0)
1 1/2 (40)	5.65 (143.5)	1.37 (34.9)	1.68 (42.7)	8.16 (207.2)	9.85 (250.0)	8.50 (216.0)	9.72 (247.0)	9.57 (243.0)
2 (50)	6.10 (155.0)	1.87 (47.6)	2.01 (51.05)	8.59 (218.2)	9.85 (250.0)	9.09 (231.0)	10.16 (258.0)	10.00 (254.0)
2 1/2 (65)	6.93 (176.0)	2.37 (60.3)	2.51 (63.75)	9.42 (239.2)	9.85 (250.0)	10.31 (262.0)	11.89 (302.0)	11.54 (293.0)
3 (80)	7.68 (195.0)	2.87 (73.0)	3.01 (76.45)	10.16 (258.2)	9.85 (250.0)	11.46 (291.0)	12.95 (329.0)	12.44 (316.0)
4 (100)	8.43 (214.0)	3.84 (97.6)	4.01 (101.85)	11.78 (299.2)	9.85 (250.0)	13.78 (350.0)	14.57 (370.0)	14.21 (361.0)

Rosemount 8721

FIGURE 3. Rosemount 8732/ 8742 Dimensional Drawings

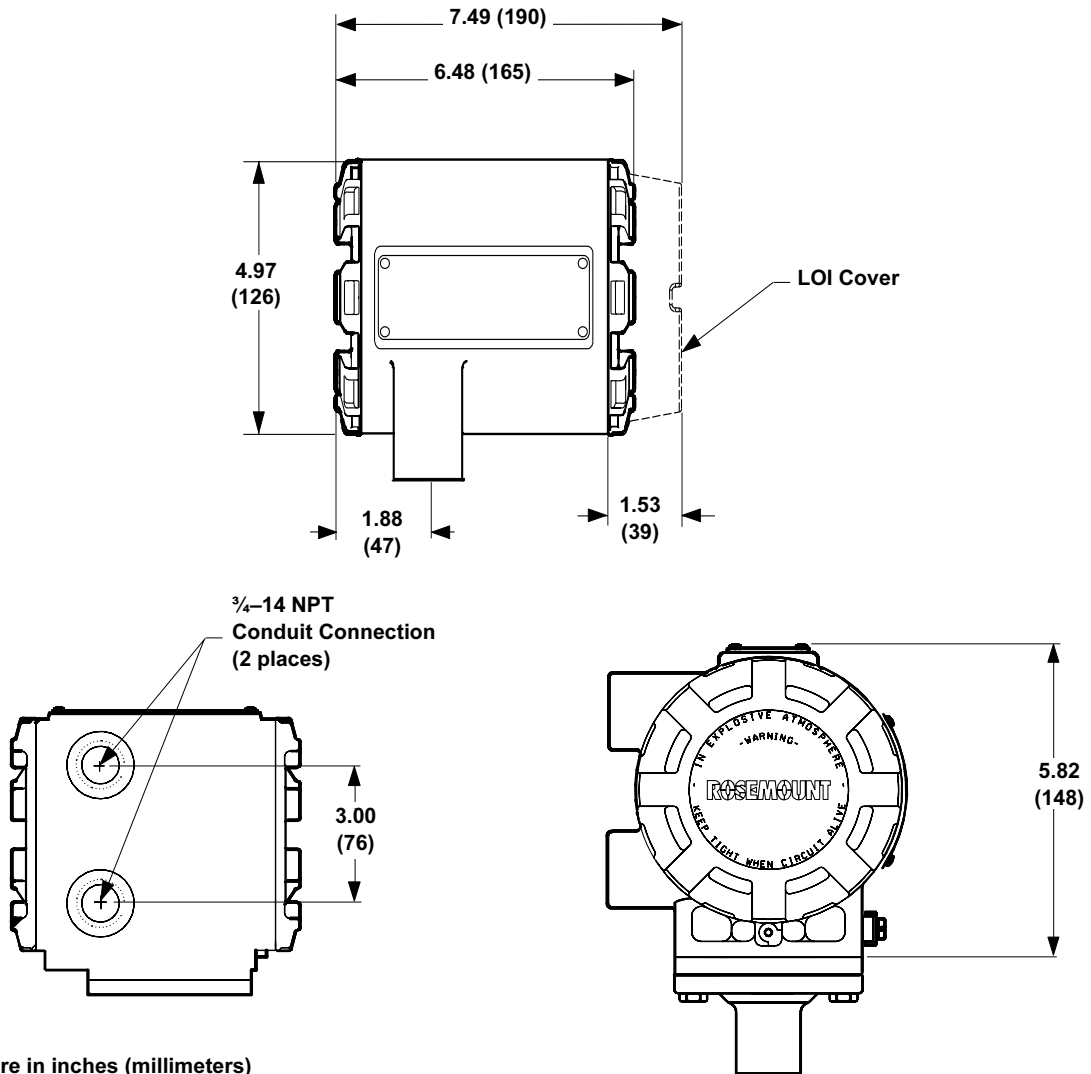

NOTE
Dimensions are in inches (millimeters)

8732-1002B01A, 1002F01A, 1002G01A

Magnetic Flowmeter Sizing

Flowmeter Sizing

Because of its effect on flow velocity, flowtube size is an important consideration. It may be necessary to select a magnetic flowmeter that is larger or smaller than the adjacent piping to ensure the fluid velocity is in the specified measuring range of the flowtube. Suggested guidelines and examples for sizing normal velocities in different applications are listed in Table 4 and Table 5. Operation outside these guidelines may also give acceptable performance.

TABLE 4. Sizing Guidelines

Application	Velocity Range (ft/s)	Velocity Range (m/s)
Normal Service	2–20	0.6–6.1
Abrasive Slurries	3–10	0.9–3.1
Non-Abrasive Slurries	5–15	1.5–4.6

To convert flow rate to velocity, use the appropriate factor listed in Table 4 and the following equation:

$$\text{Velocity} = \frac{\text{Flow Rate}}{\text{Factor}}$$

Example: SI Units

Magmeter Size: 100 mm (**factor from Table 5 = 492.0**)

Normal Flow Rate: 800 L/min

$$\text{Velocity} = \frac{800 \text{ (L/min)}}{492.0}$$

$$\text{Velocity} = 1.7 \text{ m/s}$$

Example: English Units

Magmeter Size: 4 inch (**factor from Table 5 = 39.679**)

Normal Flow Rate: 300 GPM

$$\text{Velocity} = \frac{300 \text{ (gpm)}}{39.679}$$

$$\text{Velocity} = 7.56 \text{ ft/s}$$

TABLE 5. Line Size vs. Conversion Factor

Nominal Line Size Inches (mm)	Gallons Per Minute Factor	Liters Per Minute Factor
1/2 (15)	0.941	11.67
1 (25)	2.693	33.407
1½ (40)	6.345	78.69
2 (50)	10.459	129.7
2½ (65)	14.922	185.0
3 (80)	23.042	285.7
4 (100)	39.679	492.0

TABLE 6. Line Size vs. Velocity/Rate

Nominal Line Size in Inches (mm)	Minimum/Maximum Flow Rate							
	Gallons per Minute				Liters per Minute			
	at 0.04 ft/s (Low-flow Cutoff)	at 1 ft/s (Min Range Setting)	at 3 ft/s	at 30 ft/s (Max Range Setting)	at 0.012 m/s (Low-flow Cutoff)	at 0.3 m/s (Min Range Setting)	at 1 m/s	at 10 m/s (Max Range Setting)
1/2 (15)	0.038	0.941	2.82	28.23	0.14	3.50	11.67	116.7
1 (25)	0.108	2.694	8.08	80.813	0.41	10.18	33.40	334.07
1½ (40)	0.254	6.345	19.03	190.36	0.96	23.98	78.69	786.9
2 (50)	0.418	10.459	31.37	313.77	1.58	39.54	129.7	1,297
2½ (65)	0.597	14.922	44.77	447.66	2.22	55.51	185.0	1,850
3 (80)	0.922	23.042	69.12	691.26	3.49	87.10	285.7	2,857
4 (100)	1.588	36.679	119.0	1,190.4	6.00	138.6	492.0	4,920

Upstream/Downstream Piping Length

To ensure specification accuracy over widely varying process conditions, install the flowtube with a minimum of five straight pipe diameters upstream and two straight pipe diameters downstream from the electrode plane. See Figure 4. This procedure should adequately allow for disturbances created by elbows, valves, and reducers.

FIGURE 4. Upstream and Downstream Straight Pipe Diameters

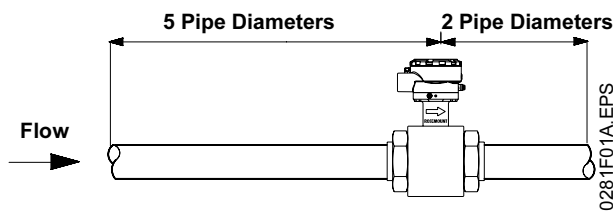

Flowtube Grounding

A reliable ground path is required between the flowtube and the process fluid. Grounding straps provided with the unit can be used to ensure proper grounding in installations with conductive, unlined pipes.

Sanitary Fitting Torque

Tighten fittings to normal hard hand tight (approximately 50 in-lbs [5½ Newton-meters (Nm)]) of torque. Re-tighten after a few minutes until there are no leaks (up to 130 in-lbs [14½ Newton-meters (Nm)] of torque). Fittings that continue to leak at a higher torque may be distorted or damaged.

Compression - limiting gaskets are used to meet EHEDG Document 8 requirements. These gaskets limit over-torque.

Material Selection

Electrode materials and electrode types are available on Rosemount Magnetic Flowtubes to ensure compatibility with virtually any application. See Table 7 for information on liner types and Table 8 for information on electrode materials. For further guidance on selecting materials, refer to the Magnetic Flowmeter Material Selection Guide located on Rosemount.com (document number 00816-0100-3033).

TABLE 7. Lining Material

Lining Material	General Characteristics
PFA	<ul style="list-style-type: none"> Highly chemical resistant Excellent high temperature capabilities Approved for use in food, beverage, pharmaceutical, and biotech applications

TABLE 8. Electrode Material

Electrode Material	General Characteristics
316L Stainless Steel	<ul style="list-style-type: none"> Good corrosion resistance Good abrasion resistance Not recommended for sulfuric or hydrochloric acids
Hastelloy C-276	<ul style="list-style-type: none"> Better corrosion resistance High strength Good in slurry applications Effective in oxidizing fluids
90% Platinum - 10% Iridium	<ul style="list-style-type: none"> Best chemical resistance Expensive material

TABLE 9. Gasket Material

Property	BUNA-N ⁽¹⁾	EPDM ⁽²⁾	Silicone	Viton® ⁽²⁾
Tensile Strength	Fair-Good	Good-Excellent	Good	Good-Excellent
Electrical Properties	Poor	Excellent	Excellent	Good
Weather Resistance	Good	Excellent	Excellent	Good
Ozone Resistance	Fair	Excellent	Excellent	Excellent
Heat Resistance	Good (225°F)	Excellent (275°F)	Excellent (450°F)	Excellent (400°F)
Cold Resistance	Fair-Good (-40°F)	Good-Excellent (-55°F)	Excellent (-80°F)	Good (-20°F)
Steam Resistance	Good	Good	Poor	Good
Tear Resistance	Good	Good	Excellent	Fair
Abrasion Resistance	Good	Good-Excellent	Good-Excellent	Good
Acid Resistance	Good	Good-Excellent	Good	Good
Petroleum Oil	Excellent	Poor	Good	Excellent
Flame Resistance	Poor	Poor	Poor	Good
Vegetable Oil	Good	Good (Most)	Good (Intermittent)	Excellent

(1) Buna-N is not recommended for use with CIP Sanitizing Agent OXONIA; use EPDM or Silicone.

(2) EPDM or Viton is recommended for ozone treated water.

Ordering Information

ROSEMOUNT 8721 ORDERING INFORMATION

Model	Product Description	Availability
8721	Sanitary Magnetic Flowmeter	•
Code	Lining Material	
A	PFA	•
Code	Electrode Material	
S	316L SST (standard)	•
H	Hastelloy C-276	•
P	90% Platinum-10% Iridium	•
Code	Electrode Construction	
A	Standard measurement electrodes	•
Code	Line Sizes	
005	15 mm (1/2 inch)	•
010	25 mm (1 inch)	•
015	40 mm (1 1/2 inch)	•
020	50 mm (2.0 inch)	•
025	65 mm (2 1/2 inch)	•
030	80 mm (3.0 inch)	•
040	100 mm (4.0 inch)	•
Code	Transmitter Mounting Configuration	
R	Remote, for use with 8712, or remote version of 8732/8742 transmitter	•
U	Integral, mounted to 8732/8742 transmitter	•
X	Flowtube only (does not include terminal junction box)	•
Code	Process Connection Type	
A	Tri-Clamp ⁽¹⁾	•
B	IDF Sanitary screw type ⁽²⁾	•
C	Weld nipple ⁽²⁾	•
D	DIN 11851 (Imperial)	•
E	DIN 11851 (Metric)	•
F	DIN 11864-1 form A	•
G	DIN 11864-2 form A	•
Code	Process Gasket Material	
1	Silicone gasket seal	•
2	EPDM	•
4	Viton	•
5	Buna-N	•
8	EPDM Compression - limiting ⁽³⁾	•
9	Viton Compression - limiting ⁽³⁾	•
X	No gasket (User supplied; only applicable with Process Connection B)	•
CONTINUE ON NEXT PAGE		

Product Data Sheet

00813-0100-4901, Rev FA

December 2004

Rosemount 8721

Code	Product Certifications	
N0	Factory Mutual (FM) Ordinary Location; CSA; CE Marking; 3-A; EHEDG Type EL ⁽³⁾	•
Code	Options	
AH	Electropolished process connection surface finish < 15µinch Ra (0.38µm Ra)	•
D1	High Accuracy Calibration [0.25% of rate from 3-30 ft/s (0.9-10 m/s)] matched flowtube and transmitter system	•
HD	Danfoss Lay Length	•
HP	Process Data PD340 (Alfa-Laval PD340) 250mm lay length and Tri-Clamp process connections	•
J1	CM20 Conduit Adapter (Applies to Transmitter Mount Option "R" only)	•
J2	PG13.5 Conduit Adapter (Applies to Transmitter Mount Option "R" only)	•
Q4	Inspection Certification for Calibration Data	•
Q8	Material Traceability Certificate per ISO 10474 3.1B (product contact surfaces)	•
SJ	304 Stainless Steel terminal junction box (Remote configuration only)	•

Typical Model Number: 8721 A S A 020 U A 1 N0

(1) *Tri-Clamp specification per BPE-2002*

(2) *IDF Specification per BS4825 Part 4*

(3) *EHEDG Document 8 requires mechanical compression limiting, provided by Compression - limiting gaskets for line sizes 1- 4 inch only.*

Rosemount 8721

Tagging

The flowtube and transmitter will be tagged, at no charge, in accordance with customer requirements.

The standard polyester nameplate is permanently adhered to the flowtube.

The Tag character height is 0.09 in. (2.3 mm);
2 lines of 20 characters each.

The Tag may be printed on the flowtube and/or transmitter nameplate upon request.

Ordering Procedure

To order, select the desired flowtube and/or transmitter by specifying model codes from the ordering table.

For remote transmitter applications, note the cable specification requirements.

ROSEMOUNT SMART FAMILY® INSTRUMENTS

Rosemount SMART FAMILY instruments include pressure, temperature, level, and flow measurement.

All SMART FAMILY instruments are designed to communicate using HART (Highway Addressable Remote Transducer) protocol with the hand-held HART Communicator and Emerson Process Management Control Systems.

Product Data Sheet

00813-0100-4901, Rev FA

December 2004

Rosemount 8721

*Rosemount and the Rosemount logotype, and SMART FAMILY are registered trademarks of Rosemount Inc.
PlantWeb is a mark of one of the Emerson Process Management companies.
All other marks are the property of their respective owners.
HART is a registered trademark of the HART Communication Foundations.
Foundation is a trademark of the Fieldbus Foundation.
Hastelloy and Hastelloy C are registered trademarks of Haynes International.
Teflon and Tefzel are registered trademarks of E.I. du Pont de Nemours & Co.
Tri-Clamp is a registered trademark of Tri-Clover, Inc. of the Alfa-Laval Group.
Cover Photo: triclamp8721B&W.tif*

Emerson Process Management

Rosemount Inc.

8200 Market Boulevard
Chanhassen, MN 55317 USA
T 1-800-999-9307
F (952) 949-7001

www.rosemount.com

**Emerson Process Management
Flow**

Wiltonstraat 30
3905 KW Veenendaal
The Netherlands
Tel 31 (0) 318-495-555
Fax 31 (0) 318-495-556

**Emerson Process Management
Private Limited**

Singapore Pte Ltd.
1 Pandan Crescent
Singapore 128461
Tel (65) 6777-8211
Fax (65) 6777-0947
AP.RMT-Specialist@emersonprocess.com



EMERSON
Process Management